

### PRINCETON™ RECESS BATH

Americast® brand engineered material

- 2390.202** Left Hand Outlet
- 2390.202TC** Same as above w/tub cover
- 2391.202** Right Hand Outlet
- 2391.202TC** Same as above w/tub cover
  - Acid resistant porcelain finish
  - Recess bath with integral apron and tiling flange
  - Integral lumbar support
  - Beveled headrest
  - Full slip-resistant coverage
  - End drain outlet
  - Integral base



### PRINCETON™ RECESS BATH for Above Floor Rough Installation

- 2392.202** Left Hand Outlet for above floor installation
- 2392.202TC** Same as above w/tub cover
- 2393.202** Right Hand Outlet for above floor installation
- 2393.202TC** Same as above w/tub cover

#### Nominal Dimensions:

1524 x 762 x 356mm  
(445mm for above floor installation)  
60" x 30" x 14"  
(17-1/2" for above floor installation)

#### Bathing Well Dimensions:

1423 x 635 x 337mm  
(56" x 25" x 13-1/4")

#### Compliance Certifications -

##### Meets or Exceeds the Following Specifications:

- ASME A112.19.4 for Americast Plumbing Fixtures
- ASTM F-462 for Slip-resistant Bathing Facilities
- ANSI Z124.1 Ignition Test
- ASTM E162 for Flammability
- NFPA 258 for Smoke Density

Americast® brand engineered material is a composition of porcelain bonded to enameling grade metal, bonded to a patented structural composite.



SEE REVERSE FOR PRODUCT DIMENSIONS  
AND SPECIFICATIONS

#### To Be Specified - Required:

- Color:
- Bath Faucet\*:
- Faucet Finish:
- Drain:
- Drain Finish:

\*See faucet section for additional models available

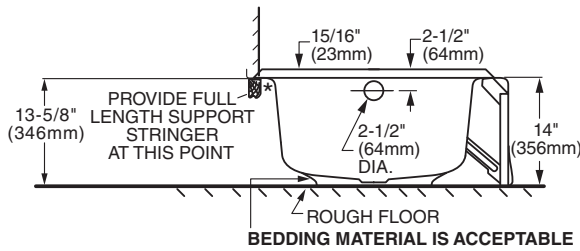

BELOW FLOOR ROUGH  
2390.202 2391.202

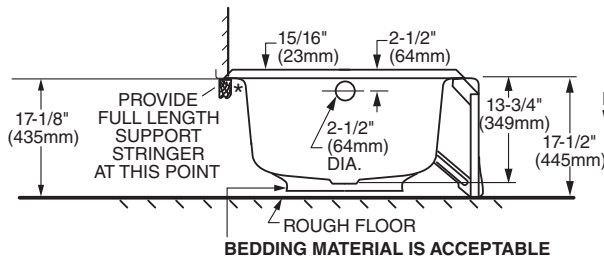

ABOVE FLOOR ROUGH  
2392.202 2393.202

\* PLUMBER NOTE: PROVIDE FULL LENGTH SUPPORT STRINGER AT THIS POINT

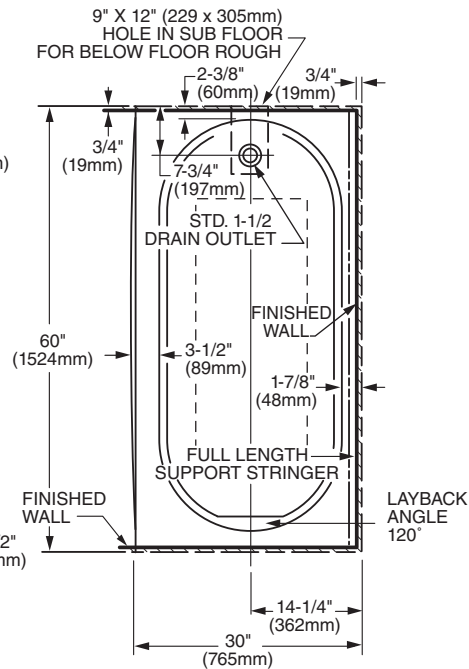

LEFT HAND TUB ILLUSTRATED  
RIGHT HAND TUB IS REVERSED

GENERAL SPECIFICATIONS FOR 2390/2391 BATHING POOL	
INSTALLED SIZE	60 x 30 x 14 In. (1524 x 762 x 356mm)
WEIGHT	110 Lbs. (50 Kg.)
WEIGHT w/WATER	460 Lbs. (209 Kg.)
GAL. TO OVERFLOW	42 Gal. (159 L)
BATHING WELL AT SUMP	42 x 19 In. (1067 x 483mm)
BATHING WELL AT RIM	56 x 25 In. (1423 x 635mm)
WATER DEPTH TO OVERFLOW	9-1/2 In. (241mm)
FLOOR LOADING (PROJECTED AREA)	37 Lbs./Sq.Ft. (175 Kgs./Sq.m)
PTS.	6.2
CUBE (FT <sup>3</sup> )	18.1

GENERAL SPECIFICATIONS FOR 2392/2393 BATHING POOL	
INSTALLED SIZE	60 x 30 x 17-1/2 In. (1524 x 762 x 445mm)
WEIGHT	119 Lbs. (54 Kg.)
WEIGHT w/WATER	469 Lbs. (213 Kg.)
GAL. TO OVERFLOW	42 Gal. (159 L)
BATHING WELL AT SUMP	42 x 19 In. (1067 x 483mm)
BATHING WELL AT RIM	56 x 25 In. (1423 x 635mm)
WATER DEPTH TO OVERFLOW	9-1/2 In. (241mm)
FLOOR LOADING (PROJECTED AREA)	38 Lbs./Sq.Ft. (182 Kgs./Sq.m)
PTS.	7.4
CUBE (FT <sup>3</sup> )	21.2

Below is shown typical cross sections of the tub rim showing typical wall constructions.

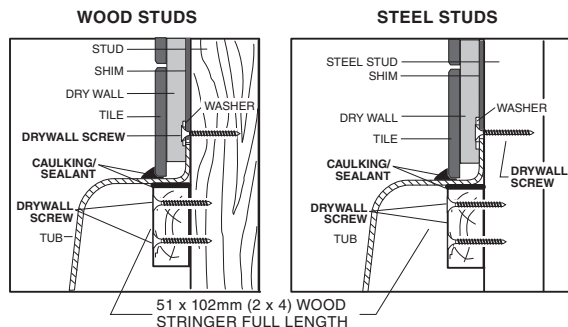

### NOTES:

LEFT HAND OUTLET SHOWN, RIGHT HAND REVERSE DIMENSIONS. (2391.202).

SHOWN WITH POP-UP C.D. & O.

REFER TO INSTALLATION INSTRUCTIONS SUPPLIED WITH FITTING.

CONCEALED PIPING NOT FURNISHED.

FITTINGS NOT INCLUDED AND MUST BE ORDERED SEPARATELY.

PROVIDE SUITABLE REINFORCEMENT FOR ALL WALL SUPPORTS.

■ REFER TO INSTALLATION INSTRUCTIONS SUPPLIED WITH BATH.

**IMPORTANT:** Dimensions of fixtures are nominal and may vary within the range of tolerances established by ANSI Standard A112.19.4 These measurements are subject to change or cancellation. No responsibility is assumed for use of superseded or voided leaflet.