

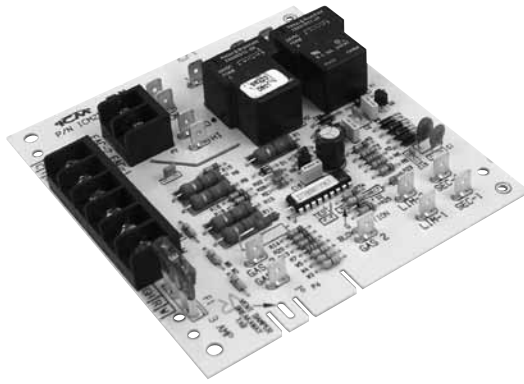

ICM271 Fan Control Center



Installation, Operation & Application Guide

For more information on our complete range of American-made products – plus wiring diagrams, troubleshooting tips and more, visit us at www.icmcontrols.com



Replacement Description

The **ICM271** Fan Control Center is a solid state control designed and engineered for the replacement market. The **ICM271** is designed specifically to replace the Carrier/BDP Gas Furnace Control Centers that have been used in new equipment for many years. The **ICM271** is a form, fit and functional replacement of the OEM control requiring no modifications to the original wiring or to the appliance's sheet metal.

The **ICM271** is a form, fit and functional replacement of the OEM control for the following Carrier/BDP part numbers:

302075-3	HH84AA010	HH84AA013
CES0110017	HH84AA011	HH84AA020
CES0110018	HH84AA012	P771-7002

ICM271 Component Layout

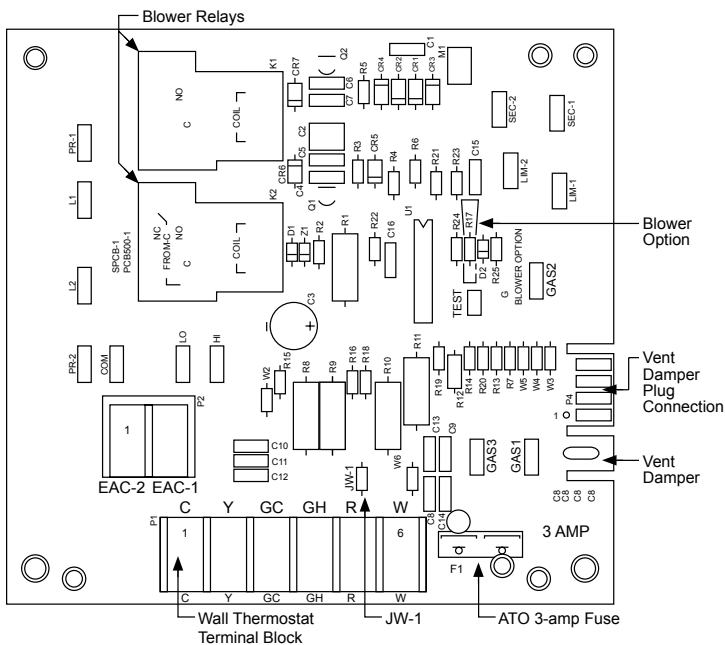

Specifications

- **Input Voltage**
 - Terminals: PR-1, PR-2, L1 and L2..... 120 VAC
 - Terminals: SEC-1 and SEC-2..... 18-30 VAC
- **Line Frequency**..... 60 Hz
- **Operating Temperature**..... -40°F to +176°F
- **Maximum Operating Humidity** 95% R.H. Non-condensing @ 50°C
- **Time Delays**
 - Heat **ON**..... 75 Seconds
 - Heat **OFF**..... 105 Seconds
 - Cool **OFF**..... 90 Seconds

Pre-Installation Instructions

- Turn off gas supply and electrical power to equipment before servicing
- **CAUTION!** This device should be installed by a qualified technician with due regard for safety as improper installation could result in hazardous conditions.
- **CAUTION!** Failure to carefully read and follow these instructions before servicing or operating this control, could result in personal injury, death and/or property damage.
- **CAUTION!** Do not short out terminals on the gas valve or the ignition control module. A short or incorrect wiring will burn out the thermostat heat anticipator. It could also result in personal injury, death and/or property damage.

Operational Differences

The **ICM271** has the same features and functions as the current Carrier/BDP replacement (HH84AA020). The **ICM271** has additional optional features and some slight operational differences than the older obsolete Carrier/BDP units. These options and operational differences are listed below.

** Note: Some older Carrier models did not have a cooling fan relay.

1. On older Carrier/BDP models, the low-speed blower would still function if the 24 volt transformer malfunctions. This will not happen with the **ICM271**.
2. If the **JW1** jumper is cut, a constant low-speed blower will occur without any thermostat signal. Also, a signal applied to the **GC** or **Y** terminals **will not** bring on the hi-speed blower during the cooling mode. Therefore, the **JW1** jumper **must not** be cut on cooling applications.
3. The 24 volt circuit is fuse protected which is not true on earlier Carrier/BDP models. A 3 amp automotive type fuse is used to protect the thermostat and transformer circuits from shorts.
4. The **ICM271** has an easy-to-remove vent damper jumper plug. This jumper plug is factory assembled for use on applications **not having** a vent damper. If the application has a vent damper, remove the jumper plug and connect the vent damper wiring harness connector to the **ICM271** circuit board.

** Note: On the **ICM271**, a blown fuse will cause the lo-speed blower to come on and remain on until the fuse has been replaced.

The **GAS1-to-GAS3** connection is made by a three-wire flame-proof switch, but in some standing-pilot applications this device is not present. In such applications, a jumper must be installed between **GAS1** and **GAS3** terminals.

A jumper should only be used on applications where a jumper exists on the previous furnace fan control board. This jumper should also include a male 1/4" spade connector to connect to your current gas valve's wiring harness.

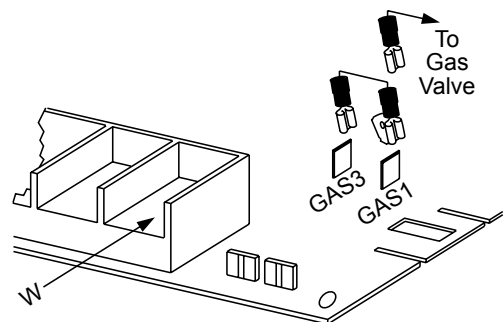

Blower Speed Output

- Turn off gas supply and electrical power to equipment before servicing

CAUTION!: Do not use this option on paired furnace applications.

The ICM271 has different blower speed options to match a specific application (see chart). The blower speed option used on the original furnace control may be very difficult to determine.

1. If the old Carrier/BDP unit has (2) black relays just like the ICM271, then look for the **JW1** jumper and **R17** resistor on the Carrier/BDP board. They will be in the same location as the **JW1** and **R17** on the ICM271. If either one (**JW1** or **R17**) has been cut, then cut the ICM271 equivalent. This will match the original Carrier/BDP blower speed option.

Blower Operating Modes

Input From Thermostat	ICM271 As Shipped	G Blower Operation (Cut R17 Resistor)
W	Lo-Speed Heating Blower with 75 seconds ON Delay and 105 seconds OFF Delay	
G	High-speed cooling blower	Lo-speed heating blower
Y	No blower	Hi-speed cooling blower with 90 second OFF delay

Installation Instructions

1. Be sure all electrical power is turned off.
2. Remove control box cover, exposing the old Carrier/BDP gas furnace control center.
3. If furnace is equipped with a vent damper, disconnect the plug connector from the old board.
4. Tag each wire as it is disconnected from the old furnace control center. Disconnect all of the wiring hookups.
5. Remove the old Carrier/BDP furnace control center from the control box.
6. Install the ICM271 fan control center into the control center box. Be sure the top edge of the ICM271 is in the mounting slot, just like the original board.

**** Note:** If the ICM271 is not installed correctly (i.e. behind the slot), an electrical short could occur.
7. Reconnect all of the wires (removed in Step 4, above) to the proper terminals.
8. If the appliance had a vent damper, break the vent damper jumper plug from the ICM271. Connect the original vent damper plug onto the ICM271.
9. Restore electrical power to the furnace and put the furnace into operation. Allow the furnace to run through one complete heating or cooling cycle.
10. If the furnace is functioning properly, replace all panels and leave this instruction sheet with the homeowner.

ONE-YEAR LIMITED WARRANTY

The Seller warrants its products against defects in material or workmanship for a period of one (1) year from the date of manufacture. The liability of the Seller is limited, at its option, to repair, replace or issue a non-case credit for the purchase prices of the goods which are provided to be defective. The warranty and remedies set forth herein do not apply to any goods or parts thereof which have been subjected to misuse including any use or application in violation of the Seller's instructions, neglect, tampering, improper storage, incorrect installation or servicing not performed by the Seller. In order to permit the Seller to properly administer the warranty, the Buyer shall: 1) Notify the Seller promptly of any claim, submitting date code information or any other pertinent data as requested by the Seller. 2) Permit the Seller to inspect and test the product claimed to be defective. Items claimed to be defective and are determined by Seller to be non-defective are subject to a \$30.00 per hour inspection fee. This warranty constitutes the Seller's sole liability hereunder and is in lieu of any other warranty expressed, implied or statutory. Unless otherwise stated in writing, Seller makes no warranty that the goods depicted or described herein are fit for any particular purpose.

WARNING!: Troubleshooting should be performed by qualified technicians only. High voltage is dangerous and can cause injuries, death or property damage.

Troubleshooting

Symptom	Remedy
Low speed fan runs continuously	<ul style="list-style-type: none"> • Verify you have 24 VAC between the R and C terminals • Verify the high temperature limit switch is not open • Check fuse to verify it is not blown • Verify the fusible link is not damaged • Temporarily bypass limits for troubleshooting only
No power to the thermostat (between R and C terminals)	<ul style="list-style-type: none"> • Verify you have 24 volts between the SEC-1 and SEC-2 terminals • Verify that the high temperature limit switch is not open • Check fuse to verify it is not blown • Verify the fusible link is not damaged • Make sure the door interlock is bypassed while troubleshooting
No fan output in cool mode	<ul style="list-style-type: none"> • Verify that you have 24 volts between GC and C • Check fan connections at HI and COM • Verify high speed fan operates correctly
No fan output in heat mode	<ul style="list-style-type: none"> • Verify that you have 24 volts between W and C • Make sure you have continuity between the GAS1 and GAS3 terminals • Check fan connections at LO and COM • Verify low speed fan operates correctly
Fan cycles on and off	<ul style="list-style-type: none"> • Transformer may be damaged and creating an irregular sine wave • Thermostat output signal may be outputting an irregular sine wave (especially solid state thermostats)

Wiring Diagram

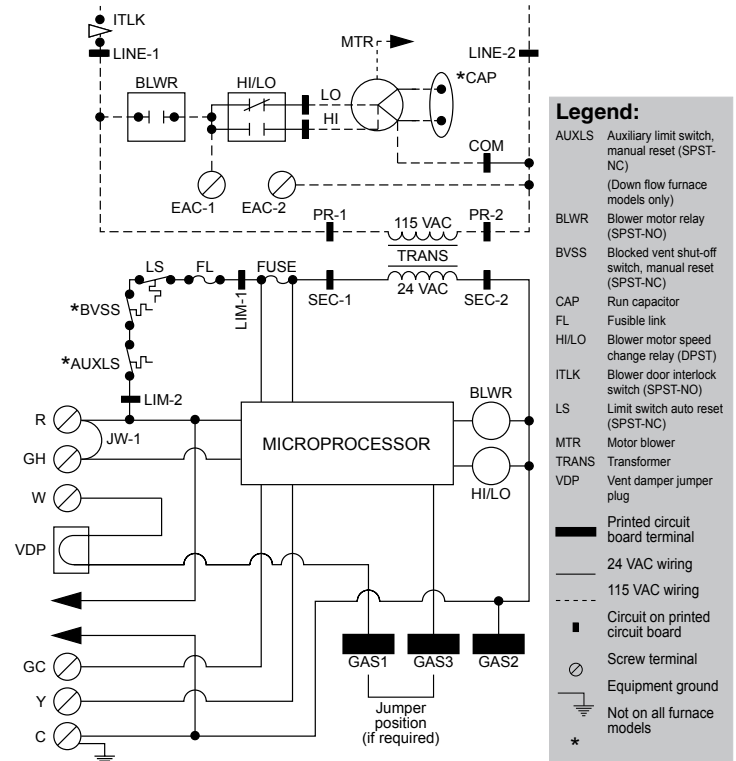

Patent No. 424,953

7313 William Barry Blvd., North Syracuse, NY 13212
 (Toll Free) 800-365-5525 (Phone) 315-233-5266 (Fax) 315-233-5276

www.icmcontrols.com

LIAF044-1