

Adjustable Pipe Saddle Support Fig. 264 (Formerly Afcon Fig. 707)

Size Range: 2½" through 36"

Material: Cast iron saddle, locknut nipple and special cast iron reducer, assembled.

Finish: Plain or Zinc Plated (Nipple Reducer Assembly cannot be Hot-Dipped).

Service: Stanchion type support where vertical adjustment of **stationary** pipe is required.

Approvals: Complies with Federal Specification A-A-1192A (Type 38), WW-H-171-E (Type 39), ANSI/MSS SP-69 and MSS SP-58 (Type 38).

Installation: Adjustment is obtained by turning the locknut nipple. The lower end of the nipple is staked, upsetting the threads to prevent separation of nipple and coupling during adjustment.

Features:

- Vertical adjustment of approximately 4½"
- Saddle supports a broad range of pipe sizes

Ordering: Specify pipe size to be supported, figure number, name and finish.

Order Separately: Figure 63T Square Cut Threaded End Stanchion. Specify "H" and pipe size to be supported by Figure 264.

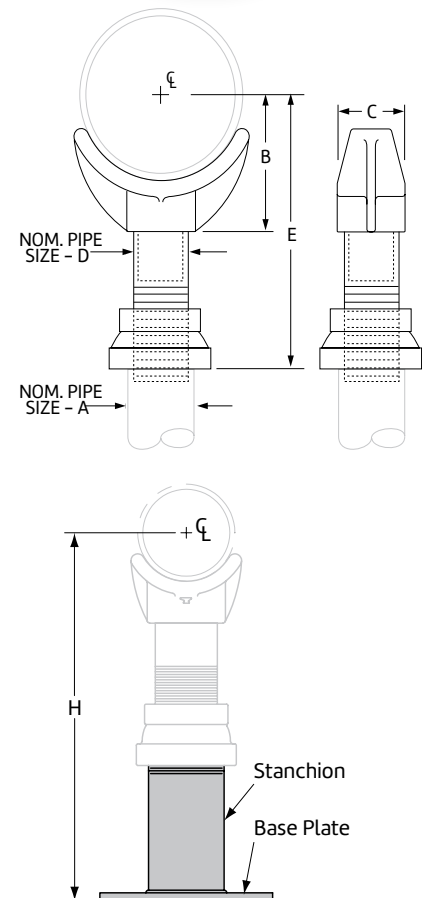

Fig. 264: Dimensions (in) • Loads (lbs) • Weight (lbs)

Pipe Size	Weight		A	B	D	E		Width C	Max Load
	Complete	Saddle Only				Min	Max		
2½	9.0	4.8		3½		8	13		
3	9.2	5.0	2½	3¾	1½	8¼	13¼	3	1,800
3½	9.4	5.2		4		8½	13½		
4	15.0	7.6		4¼		9¼	14		
5	16.7	8.3		4⅞		10	14¾		
6	17.7	10.3		5½		10½	15¼		
8	20.2	12.8	3	6⅞	2½	11¾	16½	3⅝	3,800
10	25.2	17.8		8½		13½	18¼		
12	29.0	21.6		9 ¹⁵ / ₁₆		15	19¾		
14	40.2	38.0		10 ¹⁵ / ₁₆		16¼	20¾		
16	53.2	42.0	4	12 ³ / ₈	3	17¾	22¼	4 ⁵ / ₈	5,300
18	70.8	51.0		13 ³ / ₈		19½	24		
20	104.8	85.0		15 ³ / ₈	3½	21	25½		6,700
22	121.0	98.0		15½		21 ⁵ / ₁₆	25 ¹³ / ₁₆		
24	137.0	110.0		17 ¹⁵ / ₁₆		23¾	28¼	6¾	
26	154.0	130.0	6	18½	4	24 ⁵ / ₁₆	28 ¹³ / ₁₆		7,300
30	170.0	150.0		21 ⁵ / ₁₆		27	31½		
32	181.0	161.1		22½		28¼	32¾	8¾	
36	249.0	229.0		24½		30¼	34¾		

*The special cast iron reducer may be furnished with a hexed shaped smaller end.

*Standard Wall Pipe.

The above load ratings are applicable to the saddle only and are not applicable to the stanchion or other means used to support the saddle.

Fig. 63, Type T

Square Cut Threaded End for use with Figure 264 or 265 Adjustable Pipe Saddle Support

PROJECT INFORMATION	APPROVAL STAMP
Project:	Approved
Address:	Approved as noted
Contractor:	Not approved
Engineer:	Remarks:
Submittal Date:	
Notes 1:	
Notes 2:	