

INSTALLATION INSTRUCTIONS

Maximum Torque 40 ft-lbs.

Read installation instructions first before installing. Check parts to ensure that no damage has occurred during transit and that no parts are missing. Also check the diameter of the pipe and the range marked on the clamp to ensure you have the proper size.

LIMITATIONS: For product limitations see reverse side. For more detailed information see the HDPE Products section of the Romac Product Catalog, or phone Romac Engineering Department at 1-800-426-9341.

Stiffeners with couplings for HDPE Pipe

Step 1 • Clean pipe ends for a distance of 2" greater than length of the coupling when centered over the joint.

Step 2 • Check area where gaskets will seat to make sure there are no dents, projections, gouges, etc., that will interfere with the gasket seal.

Step 3 • Insert a stiffener into the HDPE pipe ends to be joined so that the stiffener lip touches the pipe end. See reverse side for limitations based on SDR.

Step 4 • Insert wedges into stiffeners making sure wedges are not directly opposed.

Step 5 • Fix wedges firmly in stiffener by striking with a rubber hammer so that no gap exists between the back of the wedge and the inside of the pipe.

NOTE: Make sure the stiffener body does not derail from the wedge slot while hammering wedge into position. Make sure outside edge of the stiffener lip does not come in contact with the inside edge of pipe after installation.

Step 6 • Place a reference mark on the pipe an equal distance from each pipe end for centering coupling over the pipe ends. There should be a minimum of 2" inches of pipe insertion per coupling end.

Step 7 • Place one end ring on each pipe end.

Step 8 • Place one gasket next to each end ring with beveled edge toward the pipe end.

Step 9 • Slide center ring onto one of the pipes.

Step 10 • Bring the other pipe into position. Wedge should not contact opposite pipe.

Step 11 • The center ring should be centered such that the space between the OD of the pipe and the ID of the center ring is even all around the pipe. Slide gaskets into position with the beveled edge engaging the flared end of the center ring.

Step 12 • Slide the end rings into position against the gaskets. Check coupling for proper positioning over pipe ends using reference marks. (See Step 3)

Warning: Make sure the position of the coupling gasket is not positioned past the stiffener.

Step 13 • Insert bolts into end rings and tighten. Bolt tightening should be done evenly, alternating to diametrically opposite positions at approximately 20 ft-lbs increments. For best results, wait 10 minutes and retighten bolts to proper torque.

Nom. Pipe Diameter	Maximum Torque
3" - 12"	40 ft-lbs.

Note:
40 ft-lbs. torque = 12" wrench w/40 lbs. force

After pipe is pressurized, check for leakage and tighten as necessary.

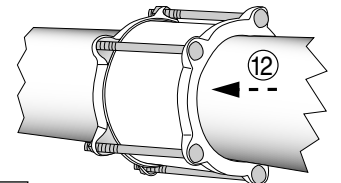
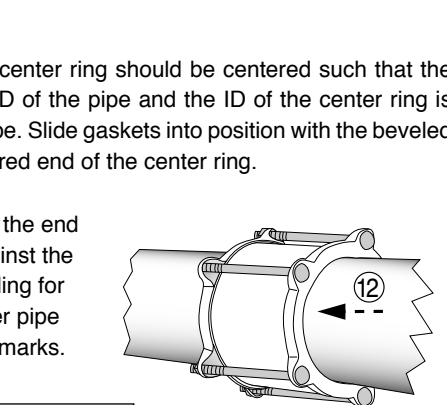
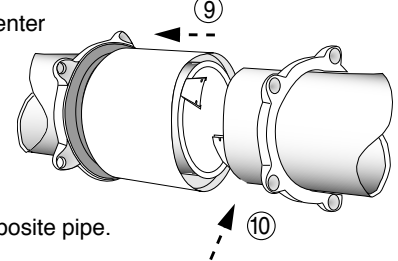
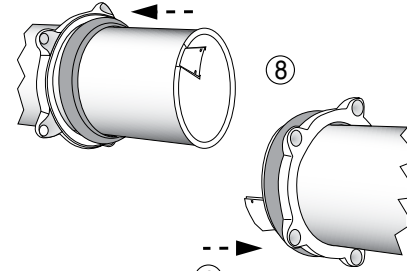
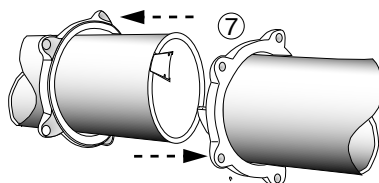
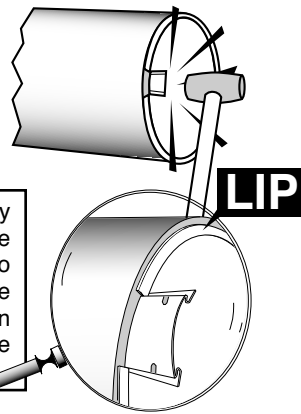
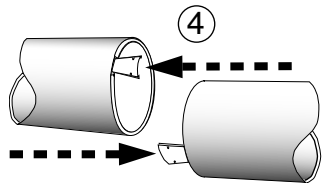
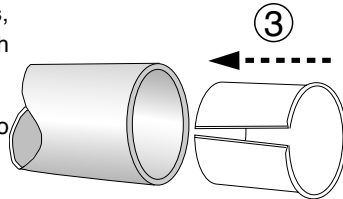

Stiffeners with Couplings for HDPE Pipe

PRECAUTIONS

1. Check diameter of pipe to make sure you are using the correctly sized coupling.
2. Clean pipe to remove as much dirt and corrosion as possible from the surface.
3. Make sure no foreign materials stick to the gasket as it is brought around the pipe, nor become lodged between gasket and pipe as nuts are tightened.
4. Avoid loose fitting wrenches, or wrenches too short to achieve proper torque.
5. Keep threads free of foreign material to facilitate tightening.
6. Bolts are often not tightened enough when a torque wrench is not used. Take extra care in this situation to make sure proper tightening occurs.
7. Always pressure test for leaks before backfilling.
8. Backfill and compact carefully around coupling.
9. Make sure the coupling gasket does not extend past the edge of the stiffener after final assembly.
10. When reinstalling parts with stainless steel hardware there may be a loss in pressure holding ability due to worn or damaged threads during the original installation

COMMON INSTALLATION PROBLEMS

1. Bolts are not tightened to proper torque.
2. Rocks or debris between pipe and gasket.
3. Dirt on threads or bolts or nuts.
4. Not using stiffeners when coupling HDPE.

PRODUCT LIMITATIONS

High Density Polyethylene Pipe (HDPE) has a lower modulus of elasticity and higher coefficient of thermal expansion than other pipe materials. These properties cause HDPE pipe to expand and contract much more from changes in temperature and/or pressure than other piping materials. Because of these and other properties, great care must be taken when installing conventional fitting on HDPE.

HDPE LIMITATIONS:

- Romac only warrants the use of Romac Stiffeners with Romac 501 Couplings with 7" long center rings and Romac Flanged Coupling Adapters
- Pipe must be manufactured in accordance with AWWA Standard C906-90.
- Operating temperatures are limited to 85° F maximum and 32° F minimum.
- Operating pressure is limited to 150 psi or the rating of the pipe, whichever is less.
- Pipe systems must be designed to compensate for pipe movement so as to prevent fittings from migrating or rotating on the pipe.
- Products are intended for use in underground service only.
- Products are not to be used on pressurized HDPE pipe with an SDR greater than 32.5.



ROMAC CANNOT WARRANT PRODUCTS USED IN APPLICATIONS THAT ARE OUTSIDE ONE OR MORE OF THESE LIMITATIONS. CONTACT ROMAC'S ENGINEERING DEPARTMENT AT 1-800-426-9341 IF YOU HAVE QUESTIONS ABOUT THE USE OF OUR PRODUCTS ON HDPE PIPE.

HDPE PRECAUTIONS:

Try always to install fittings when pipe is at its coldest.

This product is designed for a 53° F temperature range maximum.