

Commercial Flue Damper Electronic Ignition Gas Water Heater (D-Series)



Photo is of
D-75T-125-3N

FEATURING:



3 or 5-Year Limited Tank Warranties / 1-Year Limited Warranty on Component Parts.

For more information on warranty, please visit www.bradfordwhite.com

For products installed in USA, Canada, and Puerto Rico. Some states do not allow limitations on warranties. See complete copy of the warranty included with the heater.

Microban® antimicrobial product protection helps prevent the growth of bacteria, mold and mildew that may affect the product. The built-in antimicrobial properties do not protect users or others from disease-causing organisms. Microban® is a registered trademark of Microban Products Company.

The Commercial Flue Damper Models feature:

- **ICON HD**®—Intelligent proven design combines temperature control, diagnostic codes, and system ignition functions into a single control board with a digital LCD display. Control panel cover tilts down for ease of wiring and service.
- **Operation Mode**—Two different digitally displayed operation modes have the capability of adjusting the temperature setting up to 180°F (82°C), and adjusting the degree setting (°F to °C, or °C to °F).
- **Service Mode**—Eight different digitally displayed service modes can be easily cycled through by pressing the select button.
 - Adjust the temperature setting up to 180°F (82°C)
 - Change the degree setting (°F to °C, or °C to °F)
 - Lock the maximum temperature setting that can be adjusted in operation mode
 - Display the average water temperature (for two sensor models) and see the upper and lower temperature sensor readings
 - Read the flame current of the pilot flame
 - Show diagnostic codes - 16 different numeric error codes; access an error code history of the last 10 codes
- **Electronic Ignition**—High voltage, low current electricity is sent to the pilot electrode initiating a spark to ignite the pilot gas. Saves pilot gas during standby periods; the pilot flame only operates when there's a call for heat.
- **Automatic Flue Damper**—Reduces stand-by loss, saving gas consumption and improving overall efficiency.
- **Factory Installed Hydrojet® Sediment Reduction System**—Cold water inlet sediment reducing device helps prevent sediment build up in the tank.
- **Vitraglas® Lining with Microban®**—An exclusively engineered enamel formula that provides superior tank protection from the corrosive effects of water; and with Microban® antimicrobial product protection to help prevent the growth of bacteria, mold and mildew on the surface of the tank lining.
- **Insulation System**—Non-CFC foam covers the sides and top of the tank, reducing heat loss. This results in less energy consumption, improved efficiencies, and jacket rigidity.
- **Water Connections**—1½" (38mm) NPT factory-installed true dielectric fittings extend water heater life and simplify water line connections.
- **Hand Hole Cleanout**—Allows inspection of tank interior and facilitates the removal of sediment deposits.
- **E.C.O.**—An automatic reset Energy Cut Out (E.C.O.) shuts off all gas in event of an overheat condition. This automatically resets when operation conditions are back to normal.
- **Protective Anode Rods**—Provide added protection against corrosion for long-term, trouble-free service.
- **Sanitizing Capability**—Temperature setting up to 180°F (82°C).
- **ASME Code Available on all Models Above 200,000 BTU/Hr.**
- **NSF and Low NOx Natural Gas Construction Available.**
- **T&P Relief Valve**—Installed.
- **Low Restrictive Brass Drain Valve**—Durable tamper proof design.
- **Design certified by CSA International.**

Commercial Flue Damper Electronic Ignition Gas Water Heater

Electronic Ignition Models

Meet or exceed ASHRAE 90.1b (current standard) C.E.C. Listed

NATURAL GAS AND LIQUID PROPANE GAS

Model Number	Nominal Gal. Capacity		BTU/Hr. Input	LP BTU/Hr. Input	GPH Recovery at Degree Rise*			A Floor to Vent Conn. in.	B Jacket Dia. in.	C Vent Size in.	D Floor to T&P Conn. in.	E Floor to Gas Conn. in.	F Floor to Top of Heater in.	G Floor to Top Water Conn. in.	K Floor to Water Conn. Cold in.	L Floor to Water Conn. Hot in.	Depth in.	C/L of Water Conn. in.	Water Conn. NPT in.	Gas Conn. Size in.	Approx. Shipping Weight (lbs.)	
	U.S. Gal.	Imp. Gal.			40°F	100°F	140°F														Std.	ASME
D-38T-155-3N+	38	31	150,000	150,000	376	150	107	51 ⁹ / ₁₆	28 ¹ / ₄	6	34 ³ / ₈	5 ¹ / ₁₆	43 ⁹ / ₁₆	—	19 ¹³ / ₁₆	35 ⁹ / ₁₆	32 1/2	—	1 1/2 (F)	3/4	438	—
D-65T-370-3N(A)	65	54	370,000	370,000	897	359	256	71 ⁵ / ₈	28 ¹ / ₄	8	54	6 ¹ / ₄	63 ⁷ / ₈	—	28 ³ / ₄	54	33 3/8	—	1 1/2 (F)	^{1 1/2 (N)} / _{3/4 (LP)}	665	720
D-65T-399-3N(A)**	65	54	399,999	—	970	388	277	71 ⁵ / ₈	28 ¹ / ₄	8	54	6 ¹ / ₄	63 ⁷ / ₈	—	28 ³ / ₄	54	33 3/8	—	1 1/2 (F)	1(N)	665	720
D-75T-125-3N	75	62	125,000	125,000	303	121	86	76	28 ¹ / ₄	5	55 ¹³ / ₁₆	8 ¹¹ / ₁₆	65 ¹ / ₁₆	70	25 ⁷ / ₁₆	66 ¹ / ₄	32 1/2	14 ¹ / ₂	1 1/2 (T&F)	3/4	520	—
D-75T-160-3N	75	62	160,000	155,000	389	155	111	76	28 ¹ / ₄	6	55 ¹³ / ₁₆	8 ¹¹ / ₁₆	65 ¹ / ₁₆	70	25 ⁷ / ₁₆	66 ¹ / ₄	32 3/8	14 ¹ / ₂	1 1/2 (T&F)	3/4	520	—
D-75T-300-3N(A)	75	62	300,000	300,000	727	291	208	75 ⁹ / ₁₆	28 ¹ / ₄	7	52 ²³ / ₃₂	8 ¹¹ / ₁₆	65 ¹⁵ / ₁₆	—	28 ⁷ / ₈	54 ⁹ / ₁₆	33 3/8	—	1 1/2 (F)	3/4	590	645
D-80T-180-3N	80	67	180,000	180,000	436	175	124	72 ³ / ₄	28 ¹ / ₄	6	55 ⁵ / ₈	5	64 ³ / ₄	70	20	56 ¹ / ₂	32 1/2	19	1 1/2 (T&F)	3/4	540	—
D-80T-199-3N	80	67	199,999	199,999	485	194	139	72 ³ / ₄	28 ¹ / ₄	6	55 ⁵ / ₈	5	64 ³ / ₄	70	20	56 ¹ / ₂	32 1/2	19	1 1/2 (T&F)	3/4	540	—
D-80T-250-3N(A)	80	67	250,000	235,000	606	242	173	72 ³ / ₄	28 ¹ / ₄	6	55 ⁵ / ₈	5	64 ³ / ₄	70	20	56 ¹ / ₂	32 1/2	19	1 1/2 (T&F)	3/4	540	590
D-80T-425-3N(A)	80	67	425,000	425,000	1030	412	294	83 ¹³ / ₁₆	28 ¹ / ₄	10	65 ⁹ / ₁₆	6 ¹ / ₄	79 ⁹ / ₁₆	—	23 ¹ / ₂	66 ⁹ / ₁₆	34 1/2	—	1 1/2 (F)	^{1 1/2 (N)} / _{3/4 (LP)}	750	800
D-80T-505-3N(A)	80	67	505,000	505,000	1178	489	337	83 ¹³ / ₁₆	28 ¹ / ₄	10	65 ⁹ / ₁₆	6 ¹ / ₄	79 ⁹ / ₁₆	—	23 ¹ / ₂	66 ⁹ / ₁₆	34 1/2	—	1 1/2 (F)	^{1 1/2 (N)} / _{3/4 (LP)}	750	800
D-100L-199-3N	100	83	199,999	199,999	485	194	139	73 ¹ / ₄	30 ¹ / ₄	6	59 ⁹ / ₁₆	8 ¹¹ / ₁₆	65 ⁹ / ₁₆	70 ¹ / ₂	30 ⁵ / ₈	56 ⁹ / ₁₆	34 1/2	23	1 1/2 (T&F)	3/4	725	—
D-100S-199-3N	100	83	199,999	199,999	485	194	139	75 ¹¹ / ₁₆	28 ¹ / ₄	6	61 ⁹ / ₁₆	8 ¹¹ / ₁₆	68 ⁷ / ₈	70	21 ⁹ / ₁₆	61 ¹ / ₄	32 1/2	21	1 1/2 (T&F)	3/4	667	—
D-100T-199-3N	98	82	199,999	199,999	485	194	139	83 ¹³ / ₁₆	28 ¹ / ₄	6	66 ⁹ / ₁₆	8 ¹¹ / ₁₆	75 ⁷ / ₈	81 ¹ / ₂	23 ¹ / ₂	66 ⁹ / ₁₆	32 1/2	19	1 1/2 (T&F)	3/4	610	—
D-100L-250-3N(A)	100	83	250,000	250,000	606	242	173	73 ¹ / ₄	30 ¹ / ₄	6	56 ⁹ / ₁₆	8 ¹¹ / ₁₆	65 ⁹ / ₁₆	70 ¹ / ₂	30 ⁵ / ₈	56 ⁹ / ₁₆	34 1/2	23	1 1/2 (T&F)	3/4	725	765
D-100S-250-3N(A)	100	83	250,000	250,000	606	242	173	75 ¹¹ / ₁₆	28 ¹ / ₄	6	61 ⁹ / ₁₆	8 ¹¹ / ₁₆	68 ⁷ / ₈	70	21 ⁹ / ₁₆	61 ¹ / ₄	32 1/2	21	1 1/2 (T&F)	3/4	667	702
D-100T-250-3N(A)	98	82	250,000	235,000	606	242	173	83 ¹³ / ₁₆	28 ¹ / ₄	6	66 ⁹ / ₁₆	8 ¹¹ / ₁₆	75 ⁷ / ₈	81 ¹ / ₂	23 ¹ / ₂	66 ⁹ / ₁₆	32 1/2	19	1 1/2 (T&F)	3/4	610	690
D-100L-270-3N(A)**	100	83	270,000	—	655	262	187	73 ¹ / ₄	30 ¹ / ₄	6	56 ⁹ / ₁₆	8 ¹¹ / ₁₆	65 ⁹ / ₁₆	70	30 ⁵ / ₈	56 ⁹ / ₁₆	34 1/2	23	1 1/2 (T&F)	3/4	725	765
D-100L-300-3N(A)	100	83	300,000	300,000	727	291	208	73 ¹ / ₄	30 ¹ / ₄	7	56 ⁹ / ₁₆	8 ¹¹ / ₁₆	65 ⁹ / ₁₆	70	30 ⁵ / ₈	56 ⁹ / ₁₆	34 1/2	23	1 1/2 (T&F)	3/4	725	765

Model Number	Nominal Liter Capacity		LP kW Input	LPH Recovery at Degree Rise*			A Floor to Vent Conn. mm.	B Jacket Dia. mm.	C Vent Size mm.	D Floor to T&P Conn. mm.	E Floor to Gas Conn. mm.	F Floor to Top of Heater mm.	G Floor to Top Water Conn. mm.	K Floor to Water Conn. Cold mm.	L Floor to Water Conn. Hot mm.	Depth mm.	C/L of Water Conn. mm.	Water Conn. NPT mm.	Gas Conn. Size mm.	Approx. Shipping Weight (kg.)	
	22°C	56°C		78°C	Std.	ASME															
D-38T-155-3N+	144	43.9	43.9	1391	556	397	1310	718	152	873	129	1106	—	503	894	826	—	38 (F)	19	199	—
D-65T-370-3N(A)	246	108.4	108.4	3395	1359	969	1819	718	203	1370	159	1622	—	731	1370	845	—	38 (F)	^{25 (N)} / _{19 (LP)}	302	327
D-65T-399-3N(A)**	246	117.2	—	3671	1469	1048	1819	718	203	1370	159	1622	—	731	1370	845	—	38 (F)	25	302	327
D-75T-125-3N	284	36.6	36.6	1147	458	326	1930	718	127	1418	221	1653	1778	646	1683	826	368	38 (T&F)	19	236	—
D-75T-160-3N	284	46.8	45.4	1431	572	409	1930	718	152	1418	221	1653	1778	646	1683	822	368	38 (T&F)	19	236	—
D-75T-300-3N(A)	284	87.9	87.9	2752	1101	787	1919	718	178	1339	221	1675	—	733	1376	845	—	38 (F)	19	268	393
D-80T-180-3N	303	52.7	52.7	1650	662	469	1848	718	152	1413	129	1645	1778	502	1435	826	483	38 (T&F)	19	245	—
D-80T-199-3N	303	58.6	58.6	1836	734	526	1848	718	152	1413	129	1645	1778	502	1435	826	483	38 (T&F)	19	245	—
D-80T-250-3N(A)	303	73.2	68.9	2294	916	655	1848	718	152	1413	129	1645	1778	502	1435	826	483	38 (T&F)	19	245	268
D-80T-425-3N(A)	303	124.5	124.5	3899	1559	1113	2129	718	254	1684	159	2015	—	598	1684	876	—	38 (F)	^{25 (N)} / _{19 (LP)}	340	363
D-80T-505-3N(A)	303	148.0	148.0	4459	1783	1276	2129	718	254	1684	159	2015	—	598	1684	876	—	38 (F)	^{25 (N)} / _{19 (LP)}	340	363
D-100L-199-3N	379	58.6	58.6	1836	734	526	1860	768	152	1437	221	1656	1791	779	1437	876	584	38 (T&F)	19	329	—
D-100S-199-3N	379	58.6	58.6	1836	734	526	1922	718	152	1554	221	1749	1778	548	1554	826	533	38 (T&F)	19	302	—
D-100T-199-3N	371	58.6	58.6	1836	734	526	2129	718	152	1684	221	1916	2070	597	1684	826	483	38 (T&F)	19	277	—
D-100L-250-3N(A)	379	73.2	73.2	2294	916	655	1860	768	152	1437	221	1656	1791	779	1437	876	584	38 (F)	19	329	347
D-100S-250-3N(A)	379	73.2	73.2	2294	916	655	1922	718	152	1554	221	1749	1778	548	1554	826	533	38 (T&F)	19	302	318
D-100T-250-3N(A)	371	73.2	68.9	2294	916	655	2129	718	152	1684	221	1916	2070	597	1684	826	483	38 (T&F)	19	277	313
D-100L-270-3N(A)**	379	79.0	—	2479	992	708	1860	768	152	1437	221	1656	1778	779	1437	876	584	38 (F)	19	329	347
D-100L-300-3N(A)	379	87.9	87.9	2752	1101	787	1860	768	178	1437	221	1656	1778	779	1437	876	584	38 (F)	19	329	347

(A) = ASME Code Available

(F) = Front Water Connection

(T) = Top Water Connection

** = Available in Natural Gas Only

+ = Fiberglass Insulation

For Propane (LP) Gas models change suffix "N" to "X".

220V/50Hz Available - Consult factory.

* Based on manufacturer's rated recovery efficiency.

Low NOx natural gas models are not available for inputs over 399,999 BTU/Hr.

For Low NOx natural gas compliance, place an "E" following the BTU input identifier of the model number.

Example: D-75T-125E-3N

Amperage Draw = .5 for damper models/less than 4 for induced draft models.

Power Vent Kits—available for inputs from 125,000 to 505,000 BTU/Hr.

For 5 year models change suffix from "3" to "5".

Commercial Flue Damper Electronic Ignition Gas Water Heater

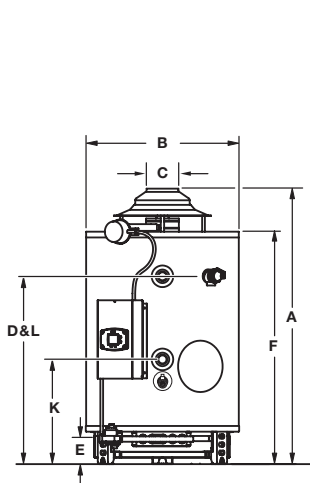

Model D-38T-155

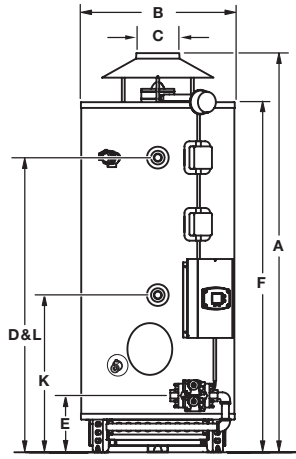

Model D-65T-(370,399)

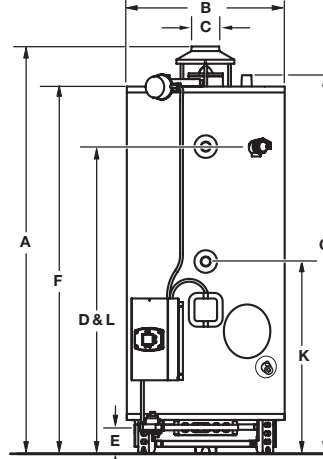

Model D-75T-(125,160)

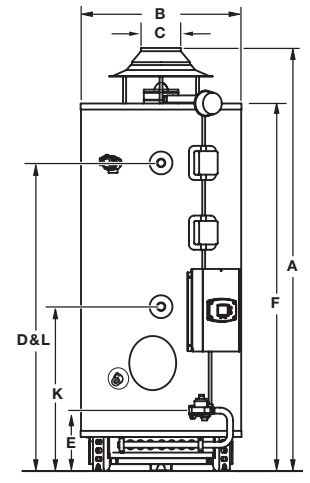

Model D-75T-300

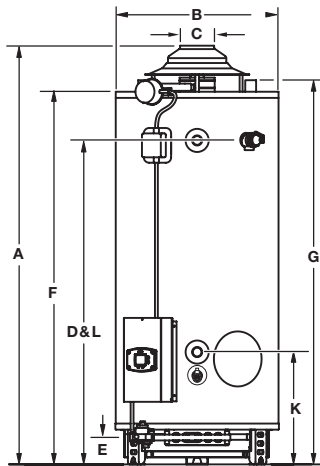

Model D-80T-(180,199,250)

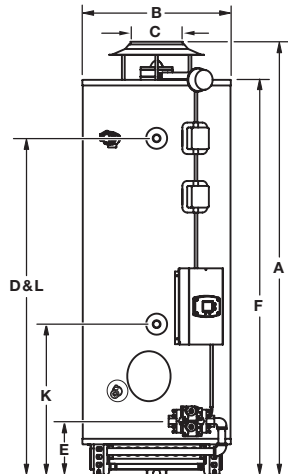

Model D-80T-(425,505)

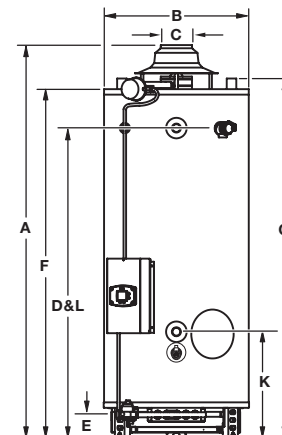

Model D-100S-(199,250)

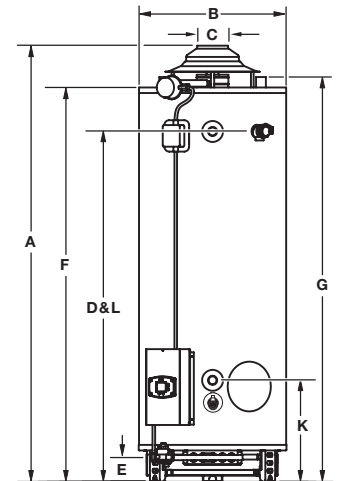

Model D-100T-(199,250)

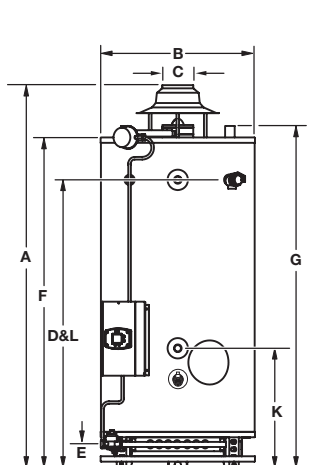

Model D-100L-(199,250,270,300)

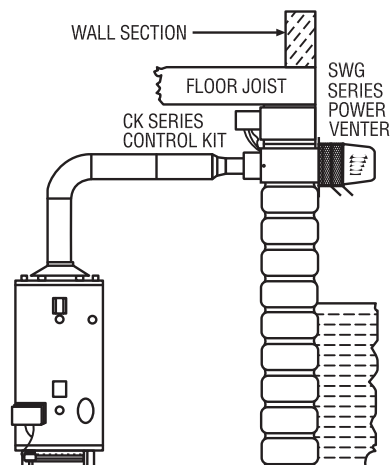

TYPICAL APPLICATIONS

Optional Equipment and Features:

Alarm Module—

Provides indication (contacts are closed) when an alarm is present via normally open contacts (rated for up to 24 VAC).

Kit Number – 265-51961-00

Power Vent Kits—

Available for inputs from 125,000 to 505,000 BTU/Hr.

BTU Input Range

125,000 to 290,000 BTU/Hr.:	239-81764-00
300,000 to 399,999 BTU/Hr.:	239-81766-00
425,000 to 505,000 BTU/Hr.:	239-82148-00

Kit Number

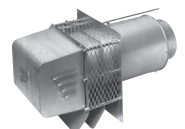

Commercial Flue Damper Electronic Ignition Gas Water Heater

Recovery Data

Model Number	GPH Recovery at Degree Rise*												LPH Recovery at Degree Rise*											
	30°F	40°F	50°F	60°F	70°F	80°F	90°F	100°F	110°F	120°F	130°F	140°F	17°C	22°C	28°C	33°C	39°C	44°C	50°C	56°C	61°C	67°C	72°C	78°C
D-38T-155-3N+	501	376	301	251	215	188	167	150	136	125	115	107	1896	1423	1139	950	814	712	632	568	515	473	435	405
D-65T-370-3N(A)	1196	897	718	598	513	449	399	359	326	299	276	256	4527	3396	2718	2264	1942	1700	1510	1359	1234	1132	1045	969
D-65T-399-3N(A)**	1293	970	776	647	555	486	432	388	353	324	299	277	4895	3672	2937	2449	2101	1840	1635	1469	1336	1226	1132	1049
D-75T-125-3N	404	303	242	202	173	151	134	121	110	101	93	87	1529	1147	916	765	655	572	507	458	416	382	352	329
D-75T-160-3N	517	388	310	259	222	194	172	155	141	129	119	111	1957	1469	1173	980	840	734	651	587	534	488	450	420
D-75T-300-3N(A)	969	727	582	485	416	364	324	291	265	243	224	208	3668	2752	2203	1836	1575	1378	1226	1102	1003	920	848	787
D-80T-180-3N	581	436	349	291	249	218	194	175	159	146	135	124	2199	1650	1321	1102	943	825	734	662	602	553	511	469
D-80T-199-3N	647	485	388	323	277	242	215	194	176	161	149	139	2449	1836	1469	1223	1049	916	814	734	666	609	564	526
D-80T-250-3N(A)	808	606	485	404	346	303	269	242	220	202	186	173	3059	2294	1836	1529	1310	1147	1018	916	833	765	704	655
D-80T-425-3N(A)	1373	1030	824	687	589	515	458	412	375	344	318	294	5197	3899	3119	2601	2223	1949	1734	1560	1420	1302	1204	1113
D-80T-505-3N(A)	1632	1224	979	816	700	612	544	490	445	408	377	350	6178	4633	3706	3089	2650	2317	2059	1855	1685	1544	1427	1325
D-100L-199-3N	647	485	388	323	277	242	215	194	176	161	149	139	2449	1836	1469	1223	1049	916	814	734	666	609	564	526
D-100S-199-3N	647	485	388	323	277	242	215	194	176	161	149	139	2449	1836	1469	1223	1049	916	814	734	666	609	564	526
D-100T-199-3N	647	485	388	323	277	242	215	194	176	161	149	139	2449	1836	1469	1223	1049	916	814	734	666	609	564	526
D-100L-250-3N(A)	808	606	485	404	346	303	269	242	220	202	186	173	3059	2294	1836	1529	1310	1147	1018	916	833	765	704	655
D-100S-250-3N(A)	808	606	485	404	346	303	269	242	220	202	186	173	3059	2294	1836	1529	1310	1147	1018	916	833	765	704	655
D-100T-250-3N(A)	808	606	485	404	346	303	269	242	220	202	186	173	3059	2294	1836	1529	1310	1147	1018	916	833	765	704	655
D-100L-270-3N(A)**	873	655	524	437	375	328	292	262	238	218	201	187	3305	2479	1984	1654	1420	1242	1105	992	901	825	761	708
D-100L-300-3N(A)	969	727	582	485	416	364	324	291	265	243	224	208	3668	2752	2203	1836	1575	1378	1226	1102	1003	920	848	787

* Based on manufacturer's rated recovery efficiency.

Sample Specification

The water heater shall be a Bradford White model with a rated storage capacity of not less than _____ gallons (_____ liters), a minimum gas input of _____ BTU/Hr. (_____ kW), a minimum recovery of _____ GPH (_____ LPH). The tank shall be Vitraglas® lined with Microban® and have a bolted hand hole cleanout. A digital LCD display shall be integrated into the front control box, and the control shall be an adjustable electronic thermostat to any temperature up to 180°F (85°C) must have an automatic re-set Energy Cut-off (E.C.O), which shuts off all gas in an event of a overheat condition. The tank shall have _____ anode rods installed in separate tank head couplings. The heater shall have Non-CFC foam insulation, electronic ignition, and come equipped with an ASME rated T&P relief valve, a cold water inlet Hydrojet® Sediment Reduction System, and a automatic flue damper (115V AC required). It shall be design certified by CSA International for 180°F (82°C) application, either with or without a separate storage tank, and comply with state and local codes and ordinances.

General

All gas water heaters are certified at 300 PSI test pressure (2068 kPa) and 150 PSI working pressure (1034 kPa). All models are design certified by CSA International (formerly AGA/CGA), ANSI standard Z21.10.3, for up to 180°F (82°C) application as an Automatic Storage Heater, and an Automatic Circulating Tank Heater. As an Automatic Storage Heater, all models are complete, self-contained water heating systems. It needs no separate storage tank, pump, wiring or elaborate piping network. When equipped with a mixing valve, it will supply 180°F (82°C) sanitizing and lower temperature general purpose hot water simultaneously. These models can be used either as a single unit or in multiples connected in series or parallel (recommended).

Dimensions and specifications subject to change without notice in accordance with our policy of continuous product improvement.

— BRADFORD WHITE IS —



Sales: 800-523-2931 ■ Fax 215-641-1612

24/7 Technical Support: 800-334-3393 ■ Email techserv@bradfordwhite.com

Products made by Bradford White are manufactured in the United States using the finest raw materials and components from around the world.

Built to be the Best®