



MANUFACTURING CO., INC.

5330 East 25th Street  
Indianapolis, Indiana 46218  
Phone (317) 261-1212  
Fax (317) 261-1208

www.lawlervalve.com

Installation &  
Maintenance Manual  
M EFV D  
PAT. NO. 5,011,074.  
PAT. NO. 5,379,936.

# Series 911<sup>®</sup>E/F Emergency Eye Wash Valve

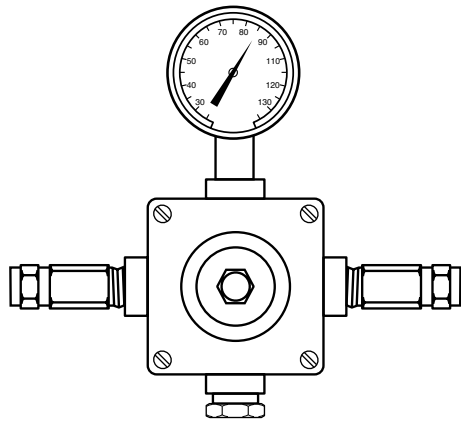

**CAPACITIES - MODEL 911E/F**

Pressure Drop PSI	5	10	20	30	45
Tempered Flow	2	3	5	7	10
Cold Water Bypass	1	2	4	5	7

## Operating Principle

This Series 911 Emergency Eye Wash/Face Wash mixing valve is made of a thermostat element with a stainless steel sliding piston and liner housed in a bronze casting. The thermostatic cartridge responds to temperature changes in the hot and cold water supplies. In the event the thermostatic element fails or the hot water supply fails, the valve will provide full cold water bypass flow.

**Note: Valve must be installed with check valves. If shut off valves are installed in the shower line for maintenance purposes, provisions shall be made to prevent unauthorized shut off.**

**Caution:** When maintaining and adjusting the mixing valve, the delivered flushing fluid temperature shall be 60°F (15°C) to 95°F (35°C). In circumstances where chemical reaction is accelerated by flushing fluid temperature, a medical advisor should be consulted for the optimum temperature for each application.

## Setting the Mixing Valve

**Caution:** When maintaining and adjusting the mixing valve, all fixtures should be isolated from use. Lawler Manufacturing Co., Inc. recommends that you work safely at all times and in a manner consistent with the OSHA Lock/Tagout standard, 29 CFR 1910.147 and other applicable standards.

This mixing valve has been set at the factory to deliver 85°F outlet flow. Should the valve require adjustment, or an application require a different set temperature, proceed as follows:

1. Contact the proper medical and safety authorities to determine the correct water temperature for the specific application (ie. chemicals).
2. Remove the rounded cover nut on front of the valve body.
3. Create a draw on the mixing valve by opening a downstream eye wash fixture.
4. Insert a 5/32" allen key into the stem opening of the valve and seat in the adjustment screw (not shown). Set the outlet temperature by turning the adjustment screw clockwise to reduce temperature, counterclockwise to increase temperature. Use the dial thermometer to measure the outlet temperature.
5. Replace rounded cover nut.

**DIMENSIONS:** 1/2" inlets & outlets

Valve Number	A	B	C
911E/F	9"	4"	8"

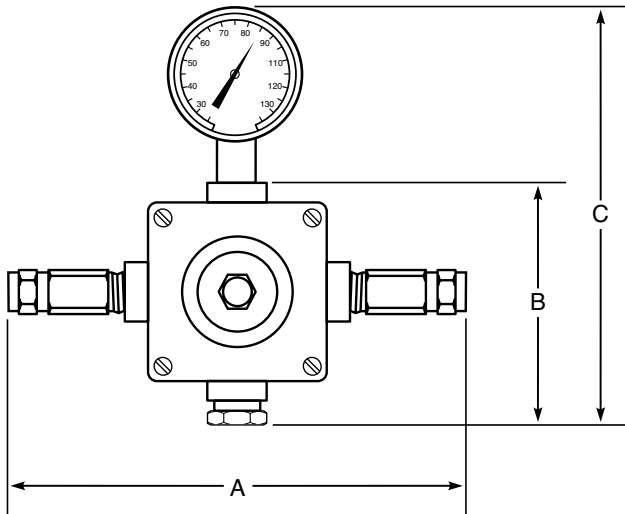

### Testing the Mixing Valve

The mixing valve and the emergency fixtures it serves should be tested weekly for proper operation.

Valve temperature test procedure is as follows:

1. Activate eye wash fixture to observe and record the temperature of the dial thermometer. If the temperature of the thermometer is not correct, readjust the mixing valve according to the section "Setting the Mixing Valve".
2. Observe the flow from the emergency fixtures to ensure an adequate flow of water.

In addition to testing for proper temperature, the cold water by-pass and hot water shut down features of the mixing valve should be tested weekly.

The test procedure is as follows:

1. Test valve temperature as described in Step 1 and Step 2 above.
2. Shut off the hot water supply to the mixing valve. Observe the outlet flow from the emergency fixtures to ensure an adequate flow of cold water. A slight drop in flow may occur after shutting down the hot water supply to the mixing valve; however, the drop should be minimal and for a short duration.
3. Open the hot water supply to the mixing valve. The thermometer should return to the set temperature.
4. Shut off the cold water supply to the mixing valve. The flow of water should shut down rapidly.

5. Open the cold water supply. The thermometer should return to the set temperature.

**Note:** The thermometer should be checked at least every six months.

### Replacing the Thermostat Element

The thermostat replacement procedure is as follows:

1. Shut off the hot water supply and cold water supply to the mixing valve.
2. Remove the four cover screws (#9) and remove the front cover (#26) of the valve.
3. Remove thermostat (#11) from the valve body. No special tools are necessary.
4. Insert a dowel rod, pencil (eraser-end), or narrow pen into the open end of the thermostat. Push on the dowel rod with your hand. If the thermostat feels spongy or springy, the thermostat has lost its charge. If the thermostat feels solid or hard, the thermostat is good and operable.
5. Be sure that the stainless steel piston (#15) moves freely up and down within the liner (#21). Lime or calcium buildup should be cleaned with vinegar, green scotch pad, or fine emery cloth.

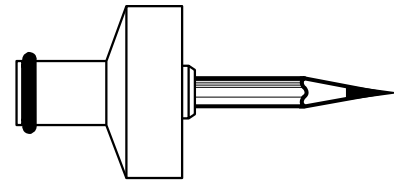

### CAPACITY OF TYPE 911E/F THERMOSTATIC MIXING VALVE FOR EMERGENCY SHOWERS

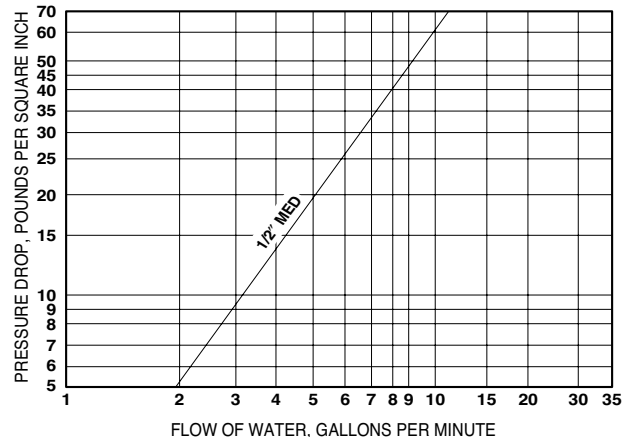

**Note:** Gallon per minute ratings may vary depending upon incoming water temperatures and pressures. Hot and cold water inlet pressures must be equal.

Provisions shall be made to thermally isolate the valve.

## Installation

After installing the mixing valve, be sure to flush the system of debris. Lawler recommends isolation and check valves for proper maintenance.

### Typical Installation *Figure 1*

When installed without a recirculation system:

Install the valve as shown in *Figure 1* with the mixing valve positioned below the hot water tank or heater. If this is not possible, pipe in heat trap as shown.

### Typical Installation *Figure 2*

When installed with a recirculating pump on the hot water supply line only:

**Note:** If the valve is installed 20 feet or more from the water heater, it is important to recirculate the hot water supply to the mixing valve.

Install the mixing valve as shown in *Figure 2*. The non-circulated loop should be limited to 10 feet and must be flushed periodically.

**Warning:** This product contains chemicals known to the State of California to cause cancer and birth defects or other reproductive harm.

(Installer: California law requires that this warning be given to the consumer.)

For more information: [www.oehha.org/prop65](http://www.oehha.org/prop65)

**Caution:** The cold water line must be installed so that it is not affected by excessively hot ambient temperatures. Provisions shall be made to thermally isolate the valve. Cold water pipe installed in the ceilings of boiler rooms or rooms that increase ambient temperature require a recirculating pump.

**Note:** The mixing valve must be installed with inlet check valves and the Eyewash/Facewash fixture should be installed 4 to 10 feet from the mixing valve.

**Note:** The valve body must be maintained at an ambient room temperature of above 50°F to prevent premature closure of the safety back-seat mechanism.

**Maximum Inlet Pressure:** 125 PSI.

**Recommended Supply Pressure:** 65 PSI.

**Recommended Inlet Temperature:** 120°F.\*

\*When supplying 140°F or greater, additional outlet controls should be used.

**Figure 1**

**Typical installation. Valve must be installed with check valves.**

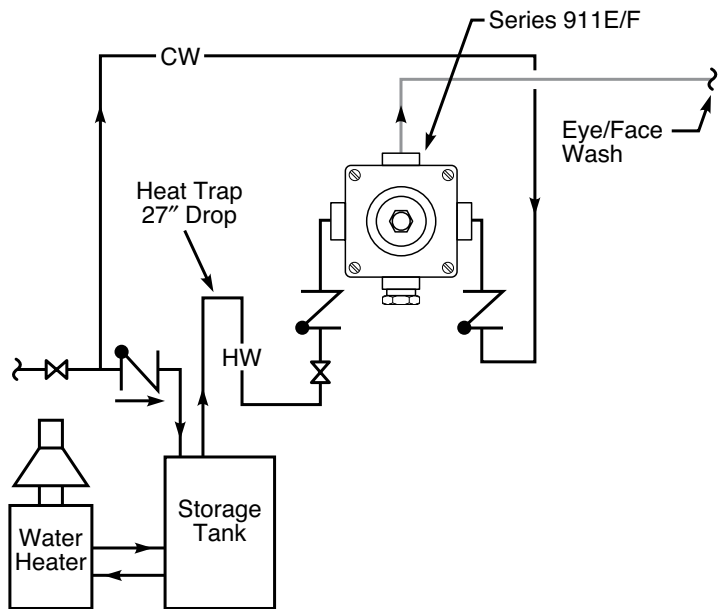

**Figure 2**

**Typical installation. Valve must be installed with check valves.**

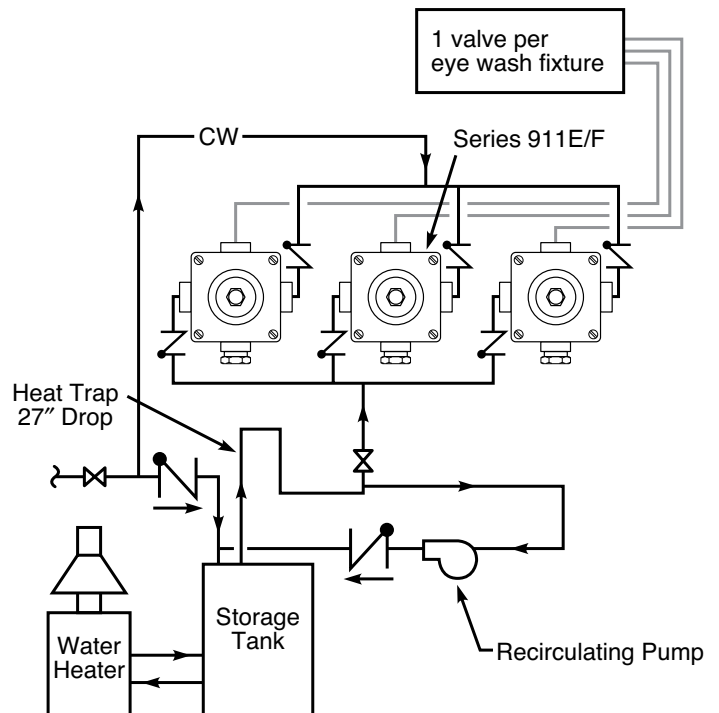

## GUARANTEE

We guarantee the Lawler Mixing Valve to be free from defects in workmanship and material, and, for a period of one year from date of purchase, will replace any parts found by Lawler Manufacturing Co., Inc. to be defective. We will not be held

responsible, however, for any labor incidental to, or for any damages caused by, defective material. Each mixing valve is thoroughly inspected and tested under actual conditions at our factory.

# Series 911E/F Test Record

Location \_\_\_\_\_

	Date	T1
YEAR	Jan	
	Feb	
	March	
	April	
	May	
	June	
	July	
	Aug	
	Sept	
	Oct	
	Nov	
	Dec	
YEAR	Jan	
	Feb	
	March	
	April	
	May	
	June	
	July	
	Aug	
	Sept	
	Oct	
	Nov	
	Dec	
YEAR	Jan	
	Feb	
	March	
	April	
	May	
	June	
	July	
	Aug	
	Sept	
	Oct	
	Nov	
	Dec	

## Parts Break Down

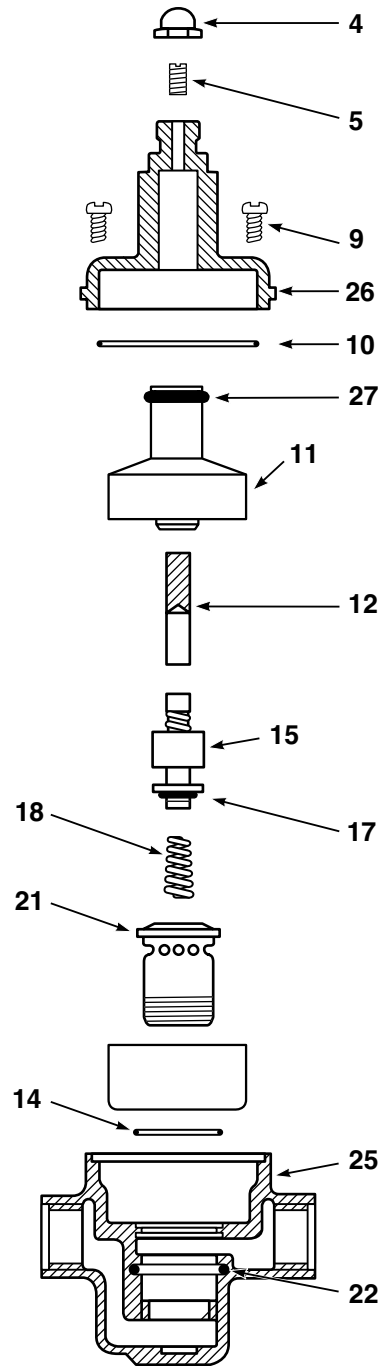

## Repair Kits and Assemblies

Item	Description	Contains	Part No.
A	Repair Kit	11-12-15-18-21+B	79854-00
B	O-Ring & Gasket Kit	10-14-17-22-27	79961-00
C	Cover Assy.	4-5-10-26	78271-00
D	Piston & Liner Assembly	14-15-21-18-17	72904-60
E	Thermostat Assy.	10-11-27	78490-00