

Installation & Maintenance Manual



RP620

**RP-Series
Indoor
Residential
Fireplace**

WARNING

If the information in these instructions is not followed exactly, a fire or explosion may result causing property damage, personal injury or death.

WARNING

Do not store or use gasoline or any other flammable vapors and liquids in the vicinity of this or any other appliance.

CAUTION





Installation and service must be performed by a qualified installer, service agency or the gas supplier.

NOTICE

Installer: Leave this manual with the appliance.
Consumer: Retain this manual for future reference.

DANGER

IF YOU SMELL GAS

-  Do not try to light any appliance.
-  Do not touch any electrical switch; do not use any phone in your building.
-  Immediately call your gas supplier from a neighbor's phone. Follow the gas supplier's instructions.
-  If you cannot reach your gas supplier, call the fire department.

NOTICE

This fireplace is certified to ANSI Z21.50 / CSA 2.22 Vented Fireplace Standard as a power assisted direct vent fireplace. This product uses outdoor air for combustion and exhausts combustion products outdoors.



NOTICE

You must read and understand this manual prior to installation, operation or troubleshooting this appliance. Please retain this owner's manual for future reference and maintenance.

Table of Contents

Instruction Manual Contents	3
Introduction	3
Section A: Before You Begin	4
Rating label sample: Natural Gas Sample Shown	4
Section 1: Product Dimensions	5
Introduction to the RP-Series Fireplace:	6
Section 2: Framing	8
Section 3: Finishing	16
Section 4: Wiring	17
Section 5: Installing the gas line	19
Section 6: Venting Configuration for PVVEX58-300, PVHEX58-300 and PVHFL58-300	20
PVVEX58-300 Vertical Power Vent Detail	21
PVVEX58-300 Power Vent Locations	22
PVHEX58-300 Horizontal Power Vent Detail	23
PVHEX58-300 Power Vent Locations	24
PVHFL58-300 Horizontal Power Vent Detail	25
PVHFL58-300 Power Vent Locations	26
Section 7: Venting Configuration for PVHIN58-300 with TMHIN58-40	27
PVHIN58-300 Inline Power Vent with TMHIN58-40 Detail	28
PVHIN58-300 Inline Power Vent with TMHIN58-40 Termination Locations	29
Section 8: Testing the System	31
Section 9: Removing / Installing the Safety Screen and Inner/Outer Windows	32
Section 10: Installing Accessories	34
Firestone / Fireglass Installation	34
Optional Speckled Stones	34
Optional Log Set	35
Operation	40
Maintenance	41
General	41
Cleaning	41
Replacing Light Bulbs	42
Servicing the Burner	43
Replacement Parts	44
Appendix A: Warranty	45
Appendix B: State of Massachusetts	46

Safety Alert Key



DANGER

Indicates a hazardous situation which, if not avoided, **WILL** result in death or serious injury or property damage.



WARNING

Indicates a hazardous situation which, if not avoided, **COULD** result in death or serious injury or property damage.



CAUTION

Indicates a hazardous situation which, if not avoided, **WILL** result in minor or moderate injury.

NOTICE

Addresses practices that are important, but not related to personal injury

Introduction

Introduction

Congratulations on your purchase of a **Montigo Fireplace**.

With over 30 years of experience, Montigo is committed to providing you with a gas fireplace that is not only a beautiful addition to your space, but that is also designed and manufactured to the highest safety, reliability and engineering standards.

We strongly encourage you to read and carefully follow the instructions laid out in this Installation, Operation and Maintenance Manual and retain it for your future reference. Pay special attention to all cautions, warnings, and notices throughout this manual intended to ensure your safety.

This manual covers installation, operation and maintenance. Lighting, operation and care of this fireplace can be easily performed by the homeowner. All installation and service work should be performed by a qualified or licensed installer, plumber or gas fitter as certified by the state, province, region or governing body where the fireplace is being installed.

This installation, operation and maintenance manual is applicable to the models described below. Refer to your rating plate to verify included options.

Warranty and Installation Information: (See Appendix B)

The Montigo warranty will be voided by, and Montigo disclaims any responsibility for, the following actions:

- ▶ Modification of the fireplace and/or components including Direct-Vent assembly or glass doors.
- ▶ Use of any component part not manufactured or approved by Montigo in combination with this Montigo fireplace system.
- ▶ Installation other than as instructed in this manual.

Consult your local Gas Inspection Branch on installation requirements for factory-built gas fireplaces. Installation & repairs should be done by a qualified contractor.

MODEL	Natural Gas	Liquid Propane	Gas Rating (BTU hr)	Linear Burner w/ Glass Accessories	Honeywell Hot Surface Ignition
RP620N-I	X		75,000	X	X
RP620L-I		X	70,000	X	X

This appliance is equipped for altitudes from 0 - 4500 feet [0 -1370 m]. For higher altitudes contact your Montigo dealer.



CAUTION

Glass doors on gas fireplaces are **extremely hot** while the fireplace is on and remain hot even after the fireplace has been turned off. This fireplace is equipped with a safety screen. Do not operate the fireplace without the safety screen. Keep children away from the fireplace at all times.



CAUTION

Young children should be carefully supervised when they are in the same room as the appliance. Toddlers, young children and others may be susceptible to accidental contact burns. A physical barrier is recommended if there are at risk individuals in the house. To restrict access to a fireplace or stove, install an adjustable safety gate to keep toddlers, young children and other at risk individuals out of the room and away from hot surfaces.

Introduction

Section A: Before You Begin

IMPORTANT MESSAGE: SAVE THESE INSTRUCTIONS

The **RP-Series** Power Vent fireplaces must be installed in accordance with these Instructions. Carefully read all the instructions in this manual first. Consult the Local Gas Branch to determine the need for a permit prior to starting the installation. It is the responsibility of the installer to ensure this fireplace is installed in compliance with the manufacturers instructions and all applicable codes.

BEFORE YOU START:

NOTICE

Installation and repairs should be done by an authorized gas fireplace service technician. The appliance should be inspected before use and at least annually by a professional. More frequent cleaning may be required due to excessive lint from carpeting, bedding material, etc. It is imperative that control compartments, burners and circulating air passageways of the fireplace are kept clean.

CAUTION

Due to high operating temperatures, this appliance should be located out of traffic & away from furniture and draperies. Children and adults should be alerted to the hazards of the high surface temperature, which could cause burns or clothing ignition. Young children should be carefully supervised when they are in the same room as the appliance. Clothing or other flammable materials should not be placed on or near the appliance.

DANGER

When this appliance is installed directly on any combustible material other than wood flooring, it must be installed on a metal or wood panel extending the full width and depth of the appliance or a fire will occur causing serious injury, property damage or even death.

Rating label sample: Natural Gas Sample Shown

*Clearance to Combustibles *Dépassements Aux Combustibles	
Sides/Côtés:	5-5/8"
Back/Derrière:	4"
Top-Top Vent/Du Haut-Évent Du Haut:	25-3/4"
Top-Rear Vent/Du Haut-Évent Arrière:	25-3/4"
Floor/Plancher:	0"
Mantel/Manteau:	2"
Recess Depth/ Profondeur D'Encadrement:	N/A
Flue:	1"
Gas Manifold Pressure / Min. Pression D'Admission Du Gaz	Min. Gas Supply Pressure/Min. Pression D'Alimentation Du Gaz
3.5" W.C.	5.5" W.C.
10" W.C.	11" W.C.

Type: Vented Gas Fireplace
 Not for use with solid fuel. / Pas pour l'usage avec le combustible solide.
 Not for use with air filters. / Pas pour l'usage avec des filtres à air.
 RP620-I

Model No. / Modèle: 2-150105-0000000000

Manufacturer / Fabricant: Canadian Heating Products Inc., Langley BC, www.montigo.com
 Montigo DelRay Corp., Ferndale, WA, www.montigo.com

Tested To / Examiné À: ANSI Z21.50-2014 / CSA 2.22-2014

Electrical Rating / Estimation Électrique: Power Vent 120V / 1Ph / 60Hz / Less than 12A

Altitude Rating / Estimation D'Altitude: N & H (0 - 4500 ft. / 0 - 1371 m).

Fuel Type / Type De Carburant:

Max. Input Max. Entrée BTU/H	Min. Input Min. Entrée BTU/H	Output / Rendement BTU/H	Orifice Size / Taille D'Orifice Front/Avant Rear/Derrière
75,000	75,000	N/A	5@47dms / N/A
70,000	70,000	N/A	5@1.20 MM / N/A

- N - Natural Gas / Gaz Naturel
- LP - Propane / Gaz Propane

FOR USE WITH GLASS DOORS AND SCREENS CERTIFIED WITH THE APPLIANCE ONLY
 Pour utilisation avec portes de verre et écrans de certifiés avec l'appareil seulement

*Refer to installation manual for more information.

*Référez-vous au manuel d'installation pour plus d'information.

LBL1207D-V5.0 R(P)VIEW_HSL_WITH_SCREEN_DEC.11.2014



Do Not Remove This Label
N'enlevez Pas Cette Étiquette

Introduction



Section 1: Product Dimensions

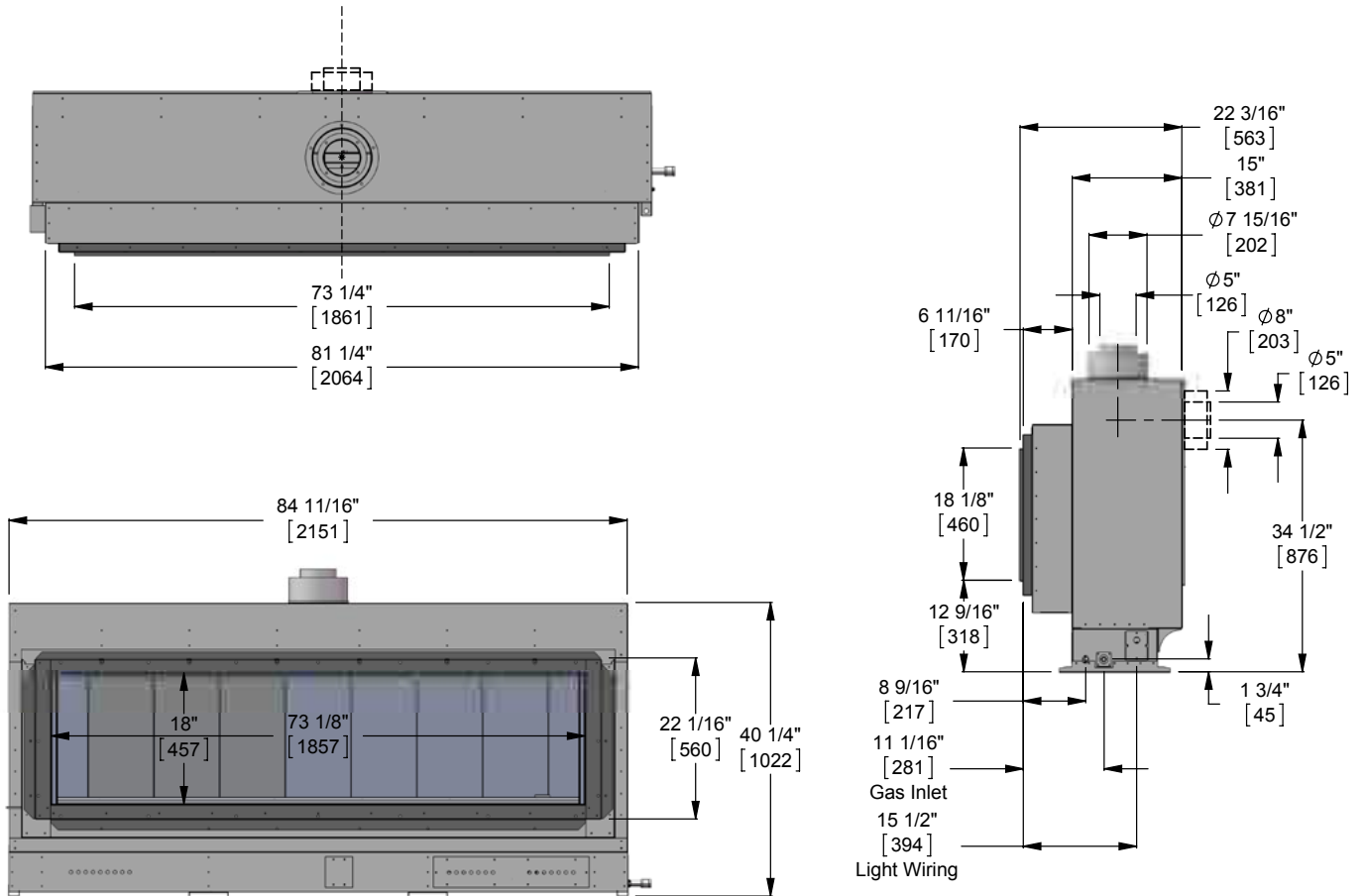

Figure 1. RP620* Fireplace Dimensions (Tolerance $\pm 1/8$ " [mm])

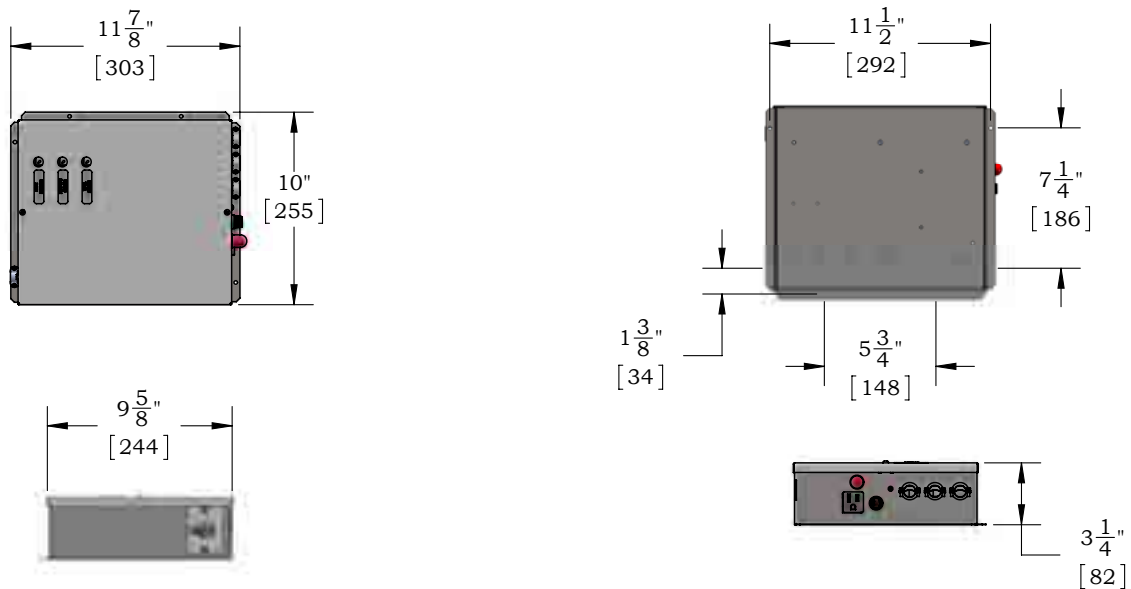

Figure 1a. RP620* Control Box Dimensions (Tolerance $\pm 1/8$ " [mm])



Introduction

Introduction to the RP-Series Fireplace:

The complete system will require a firebox, a power vent termination, an electrical control panel, and a vent system. There are 3 different power vent terminations available depending on your installation requirements. Each power vent requires a control cable to be installed between the power vent and the control panel. Review the installation sequence on page 7 for general information on preparing for a successful installation of your fireplace. **The RP-Series fireplace is not intended to be used as a primary heat source and should not be connected and operated with a thermostat switch.**

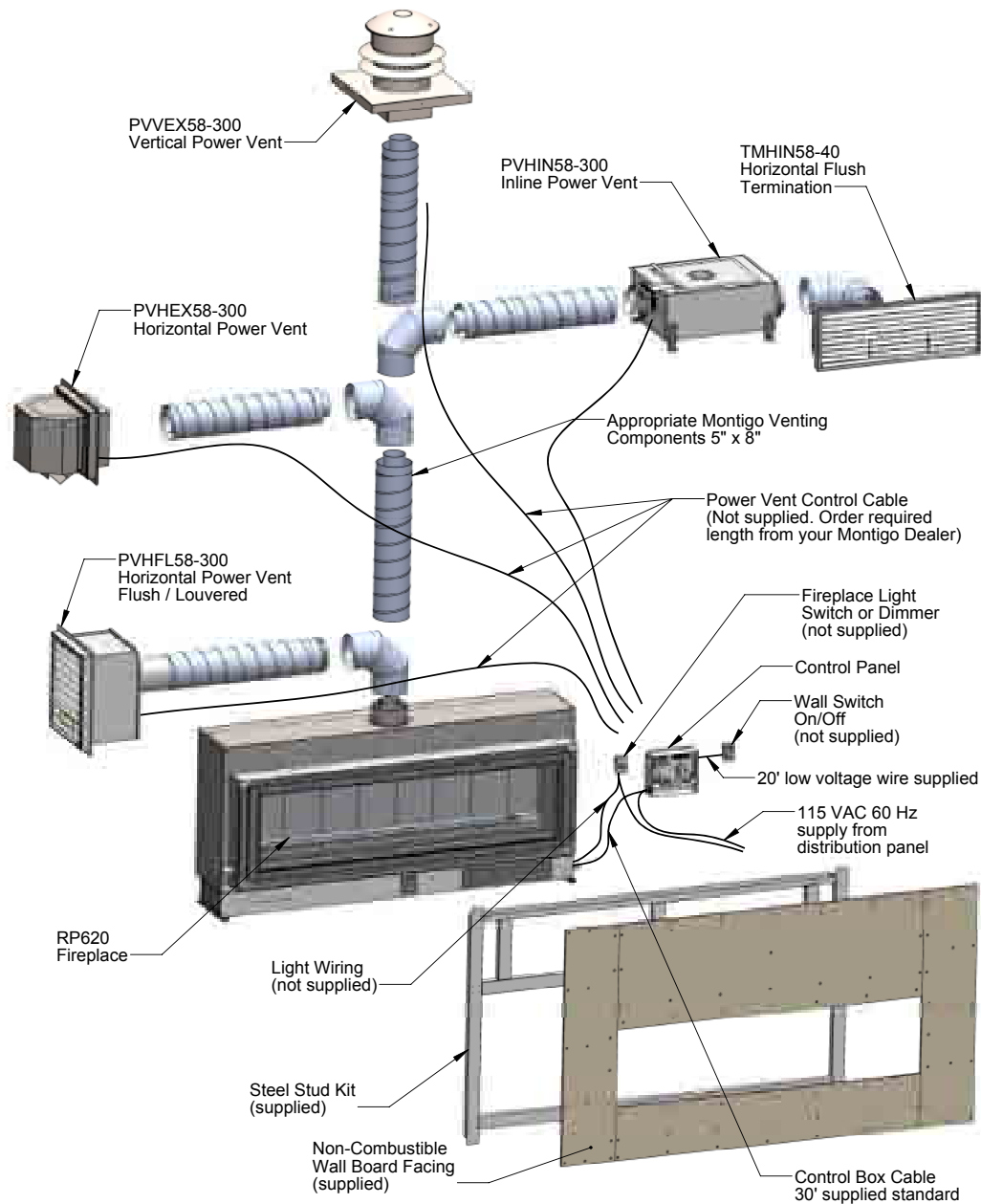

Figure 2. RP620* major components

Installation



Installation Sequence

- Unpacking and set-up
- Framing
- Fireplace placement and securing
- Power connection
- Gas connection
- Power vent termination installation.
- Vent installation.
- Test firing.
- Steel framing.
- Wall boarding / finishing
- Installation of windows / accessories

Installation and repairs should be done by a qualified contractor and must conform to:

• **Installations in Canada** must conform to the local codes or in the absence of local codes to the current version of Natural Gas and Propane Installation Code, CSA B149. Electrical Installations must conform to the local codes or, in the absence of local codes, to the current version of Canadian Electrical Code, CSA C22.1.1

• **Installations in the USA** must conform to the local codes or in the absence of local codes to the current version of National Fuel Gas Code, ANSI Z223.1/NFPA54. Electrical Installations must conform to the local codes or, in the absence of local codes, to the current version of the National Electrical Code, ANSI/NFPA 70. See **Appendix B** for installation within the State of Massachusetts.

Fuel Type

Verify that your fireplace is compatible with your available gas type. Natural Gas or Propane shown by "N" or "L" in your model number on rating plate.

Install location:

The RP-Series fireplace may be installed in any location that maintains proper clearances to air conditioning ducts, electrical wiring, and plumbing. Safety, as well as efficiency of operation, must be considered when selecting the fireplace location. Try to select a location that does not interfere with room traffic, has adequate ventilation, and offers an accessible pathway for Power Vent installation.

Basic Operation:

The gas control components of this fireplace are located in the bottom of the firebox below the burner system. All models are supplied with a Honeywell smart valve gas control and do **NOT** have a variable flame control. A differential pressure switch is located at the bottom of the firebox monitors airflow and controls the gas valve. A thermal switch located on the top of the firebox acts as a secondary safety system and shuts down the fireplace in the event that normal operating temperatures exceeded. These components communicate with the electrical control panel through a six conductor cable supplied with the fireplace.

To operate the fireplace, Montigo supplies 20' of low voltage wire from the electrical control panel. Connect the two wire harnesses to a standard single pole ON/OFF switch to the location of your choice. You may extend these wires up to 100' in length with a wire of equal quality.

This fireplace is equipped with lights which need to be wired through a wall switch or dimmer circuit as shown in the schematic.

ON/OFF control of this appliance can also be performed using an optional remote control available from your Montigo dealer.



Installation

Section 2: Framing

Clearances to combustibles:

To ensure the fireplace operates safely, all models must maintain the following clearances to combustibles:

MODEL	Top - Rear Vent †	Top - Top Vent †	Rear - Top Vent	Rear - Rear Vent	Sides	Floor	Mantel
RP620*	15 1/4"	25 3/4"	4 3/8"	4 3/8"	5 5/8"	0	2"

† **Note:** Clearance from top of fireplace to a combustible ceiling within the fireplace enclosure.

Unprotected combustible walls which are perpendicular to the fireplace opening must maintain 6" clearance, see **figure 9**.

When planning your installation, take into consideration the area around the appliance where combustible building materials cannot be placed. Regardless of the type of construction used, or if the unit is a raised installation or any other consideration or construction illustration else where in this manual, combustible materials cannot be placed in this region. This illustration depicts to a greater extent the minimum size of the fireplace chase that this appliance requires. You can also use this diagram to double check the clearances once the unit has been installed, prior to closing the fireplace enclosure.

Non-combustible installations must maintain the fireplace enclosure cavity volume minimum and a 1" clearance around the firebox.

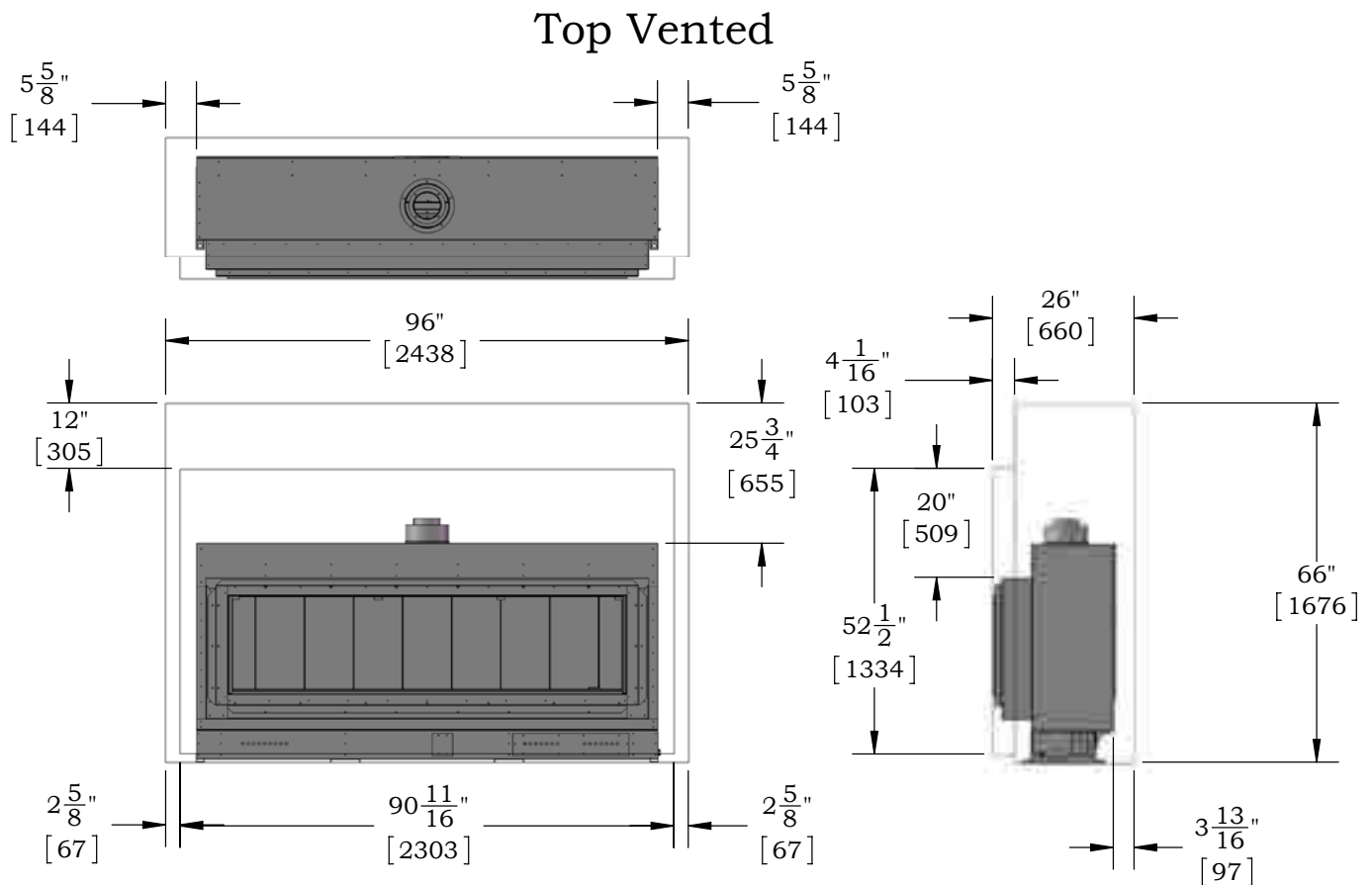

Figure 3. RP620* Top Vented Framing Clearances

Installation



Rear Vented

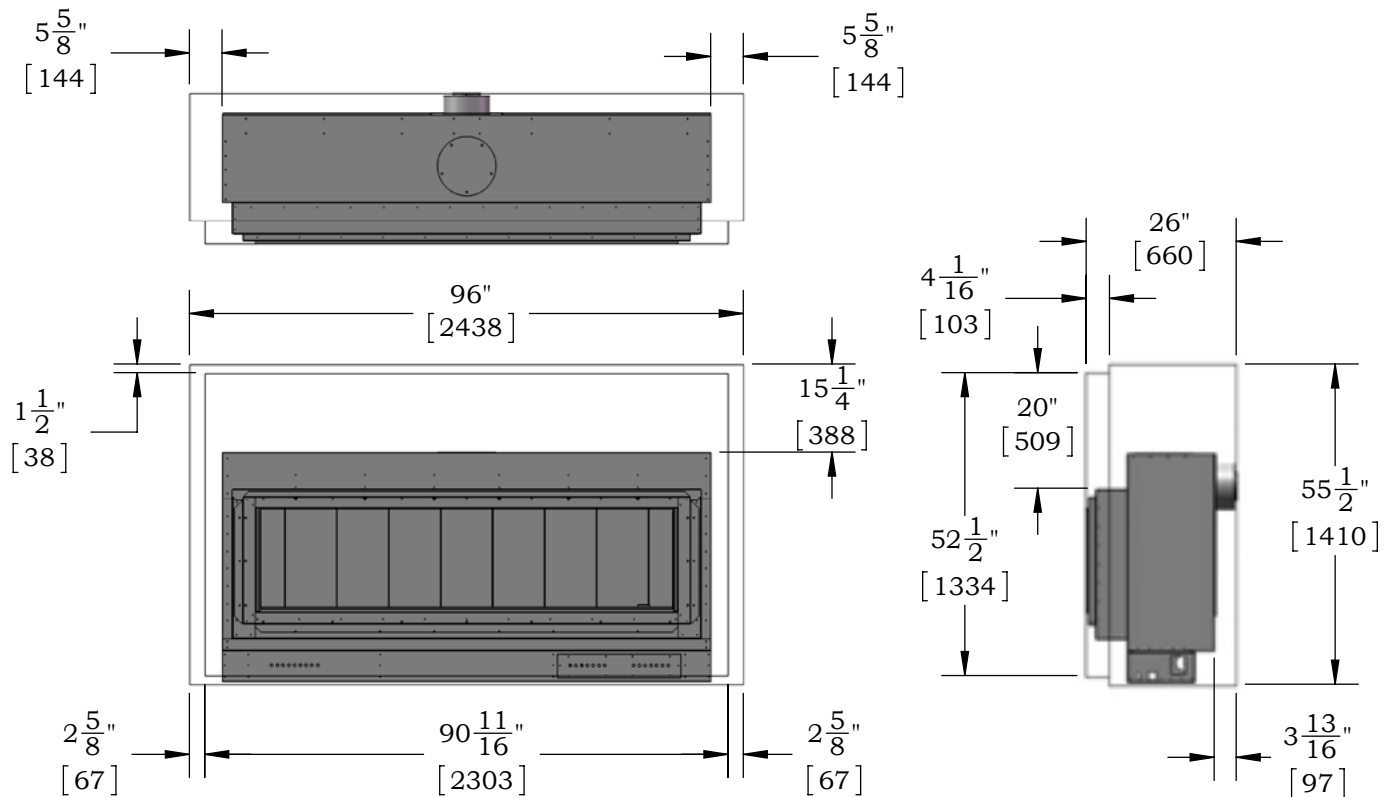

Figure 3a. RP620[®] Rear Vented Framing Clearances



Installation

Non-combustible Framing

Assemble the non-combustible framing as shown below.

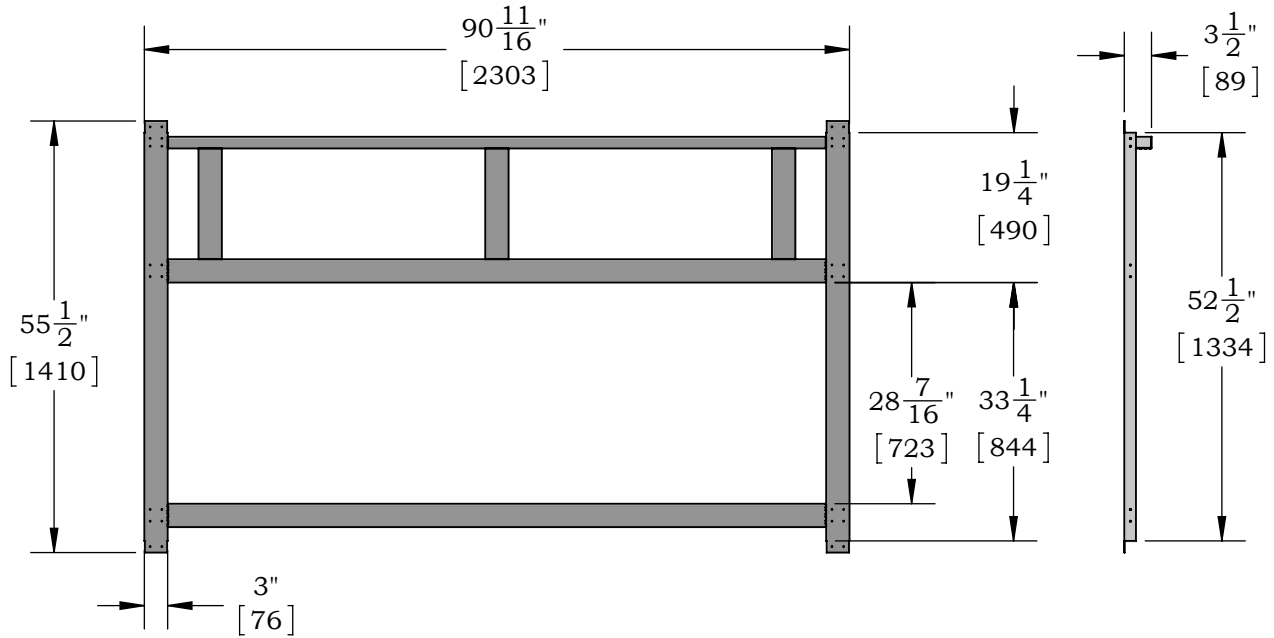

Figure 4. Non-combustible framing

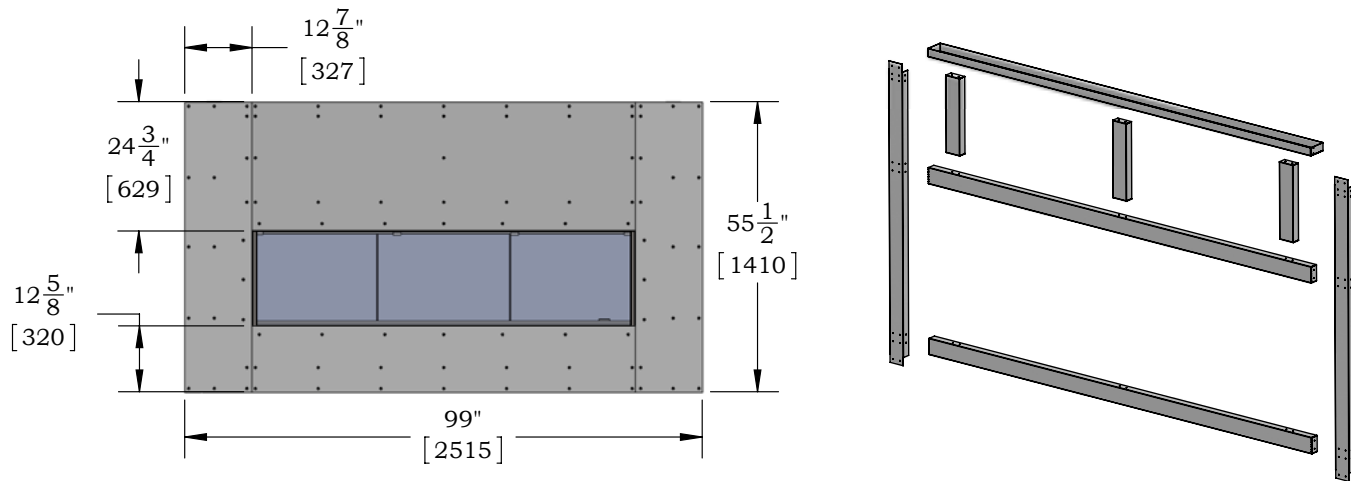

Figure 4a. Wall board dimensions as supplied.

Installation



Section 3-1: Converting to Rear Vent

RP-Series units are shipped for Top Vent installations. Follow the instructions to convert unit for Rear Vent installation.

Section 3-1-1: Converting the Flue

1. Remove the Rear flue cover with gasket (5" and 8") on the flue outlet, as shown in **Figure 5**. **ENSURE YOU DO NOT DAMAGE THE FIBER GASKETS.**

2. Remove the Top flue collar (5" and 8") on the flue outlet, as shown in **Figure 5**. **ENSURE YOU DO NOT DAMAGE THE FIBER GASKETS.**

Note: Read instructions for converting pressure sensing tube, **page 12**. You may find it easier to convert the pressure sensing tube at this time.

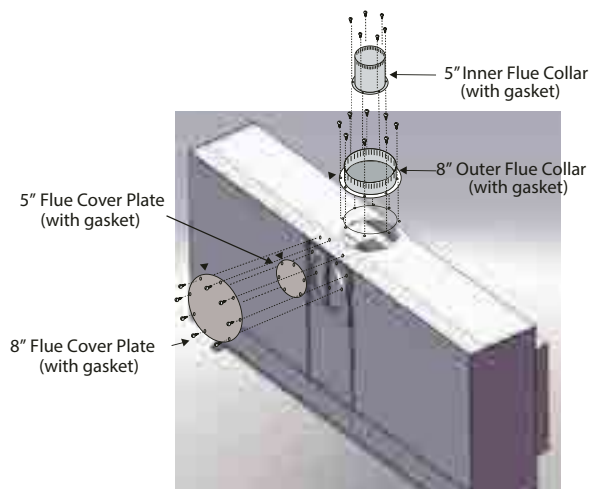

Figure 5. Flue cover and collar removal, Top Vented fireplace

3. Install the removed Rear flue cover (5" and 8") to the Top Vent outlet. Fasten the cover with included hardware, as shown in **Figure 5a**.

4. Install the collars (5" and 8") to the rear vent outlet using the included hardware, as shown in **Figure 5a**.

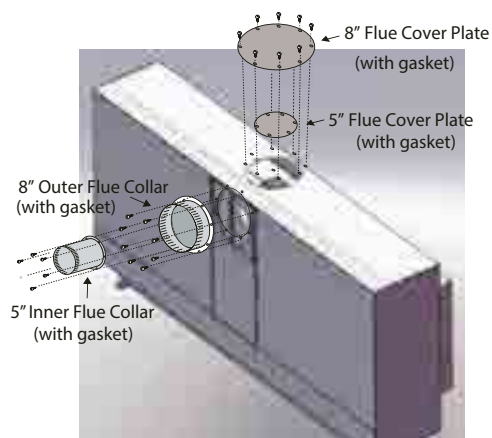

Figure 5a. Flue cover and collar installation, Rear Vented fireplace

5. Proceed to Section 3-1-2: Converting Pressure Sensing Tube and Air Baffle.



Installation

Converting the Pressure Sensing Tube

The Top Vent pressure sensing tube must be removed and replaced with supplied Rear Vent pressure sensing tube.



Figure 6. Factory installed Top Vent Pressure Sensing Tube

1. Remove six screws from the firebox ceiling baffle to access pressure sensing tube from the inside of the firebox, as shown in **figure 6b**.
2. Remove Top Vent pressure sensing tube by loosening the compression nut with a ½" wrench.

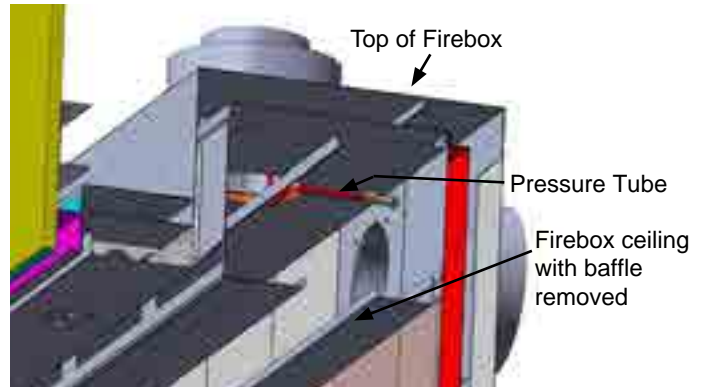

Figure 6b. Removal of Top Vent air baffle and pressure sensing tube. (cutaway view)



Figure 6a. Supplied Rear Vent Pressure Sensing Tube

3. Position the supplied Rear Vent pressure sensing tube as shown in **Figure 6c**, position the tube in the center of the 5 inch pipe. Hand tighten the compression nut and tighten half a turn with a wrench. **DO NOT OVERTIGHTEN.**
4. Re-install the firebox ceiling baffle.

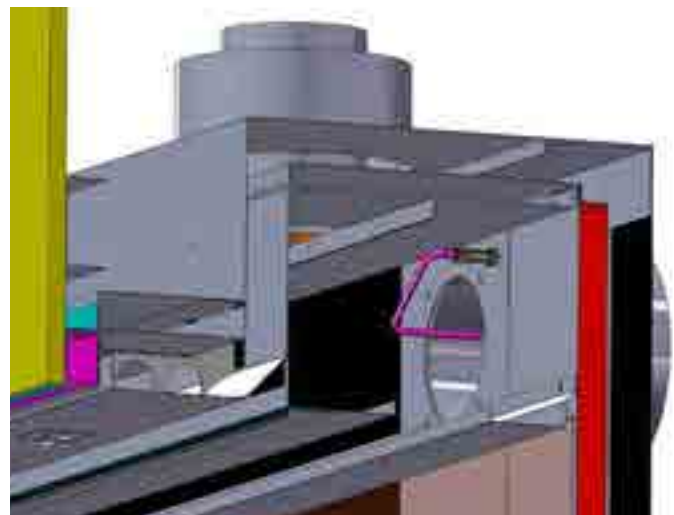

Figure 6c. Installation of Rear Vent air baffle and pressure sensing tube. (cutaway view)

Installation



Typical Framing

Framing for Top Vent installations:

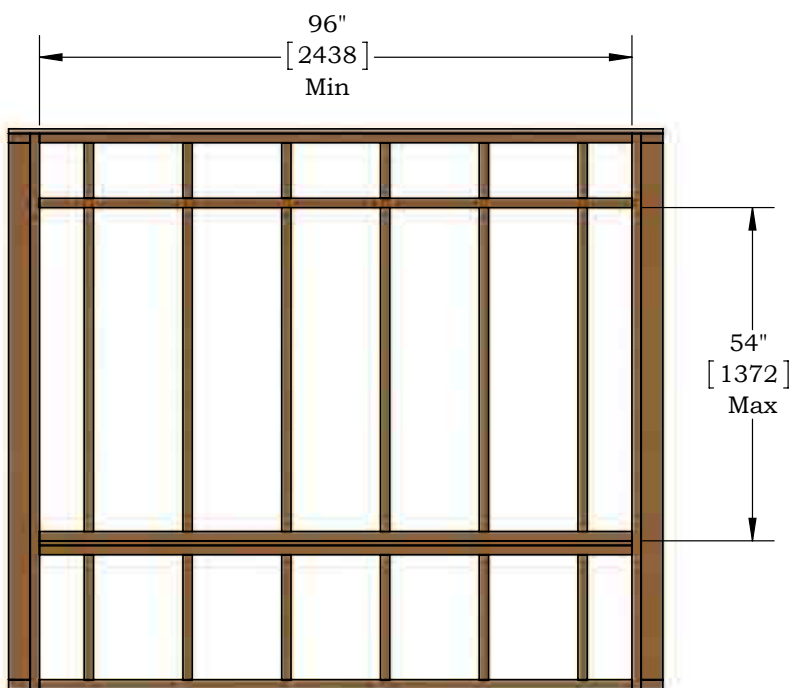
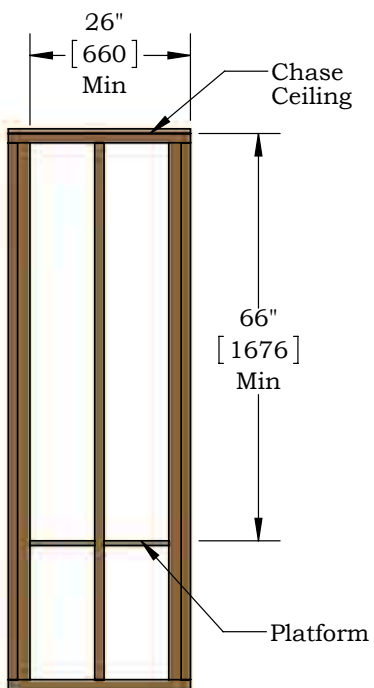
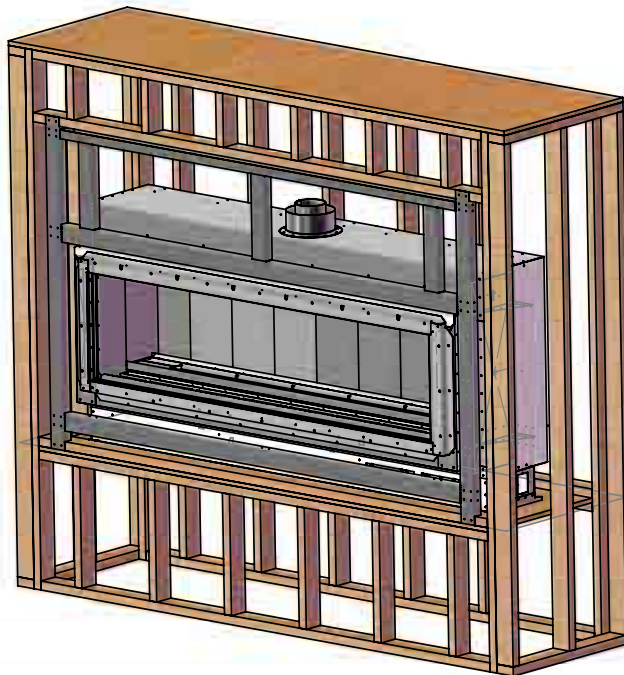

Figure 7. Framing the unit - Top Vent



Installation

Framing for Rear Vent installations:

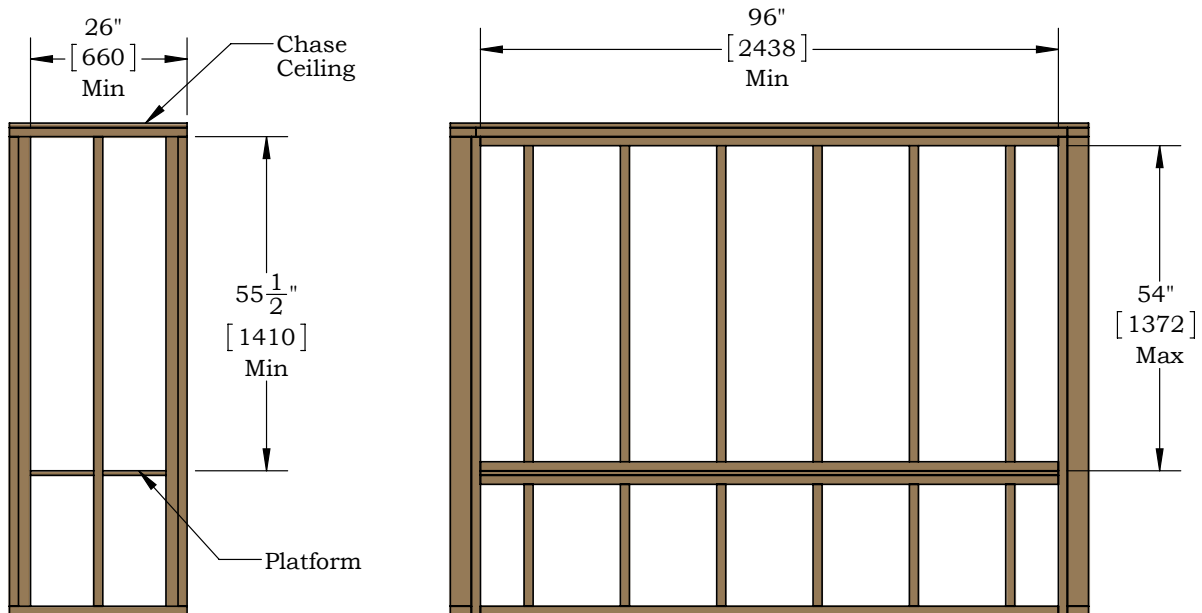
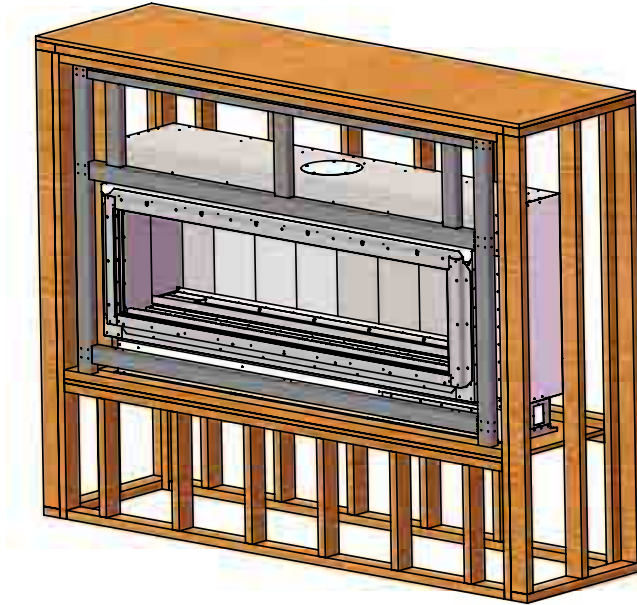

Figure 7a. Framing the unit - Rear Vent

Installation



Framing for Rear Vent, Vertical Vent Run installatic

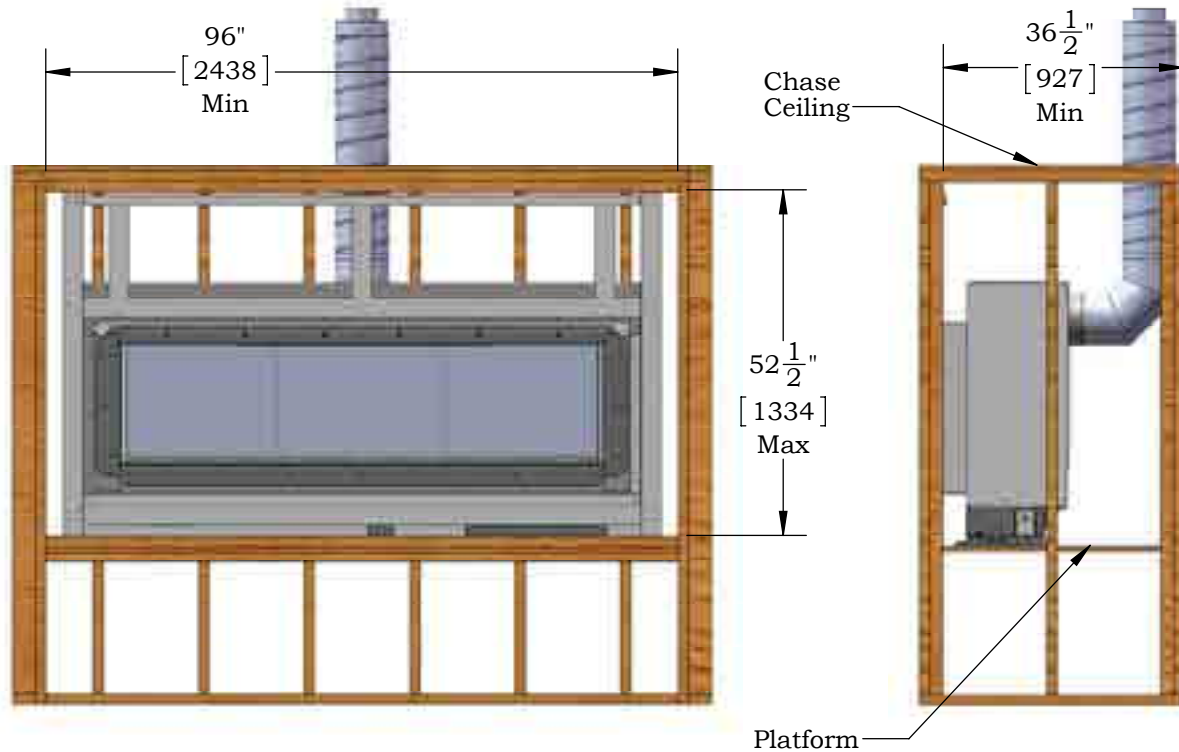
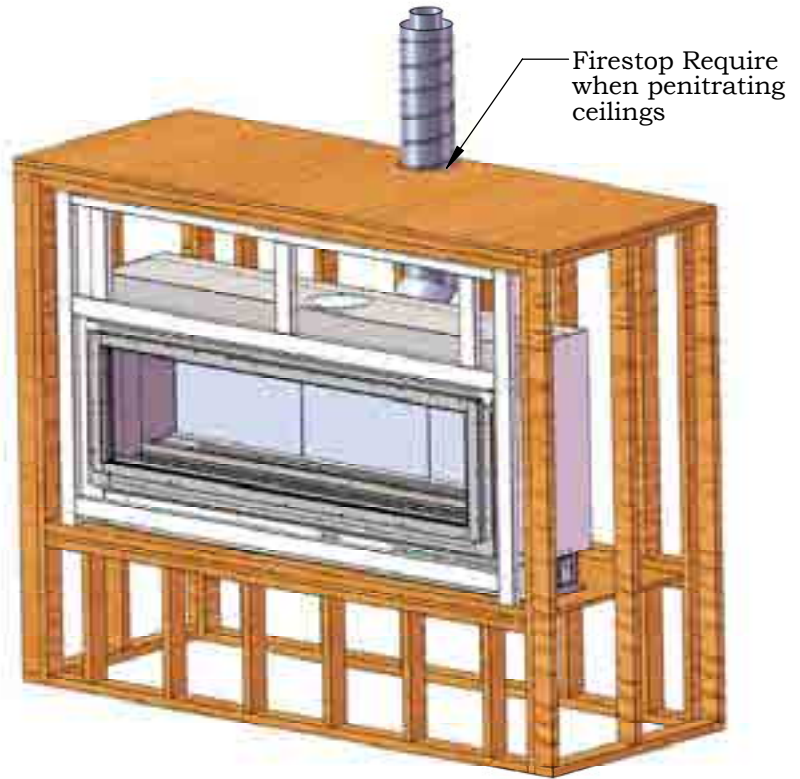

Figure 7b. Framing the unit - Rear Vent, Vertical Vent Run



Installation

Section 3: Finishing

Finishing Around the Fireplace

Non-combustible mantels and mouldings may be safely installed over the top and on the front of the fireplace provided that they do not project beyond shaded area shown in **Figure 8**.

The face of the fireplace may be painted to match the room decor, provided you use a heat-resistant paint. Decorative facing must not extend past the fireplace opening at all, because it will interfere with the access to retainers for removal of glass door.

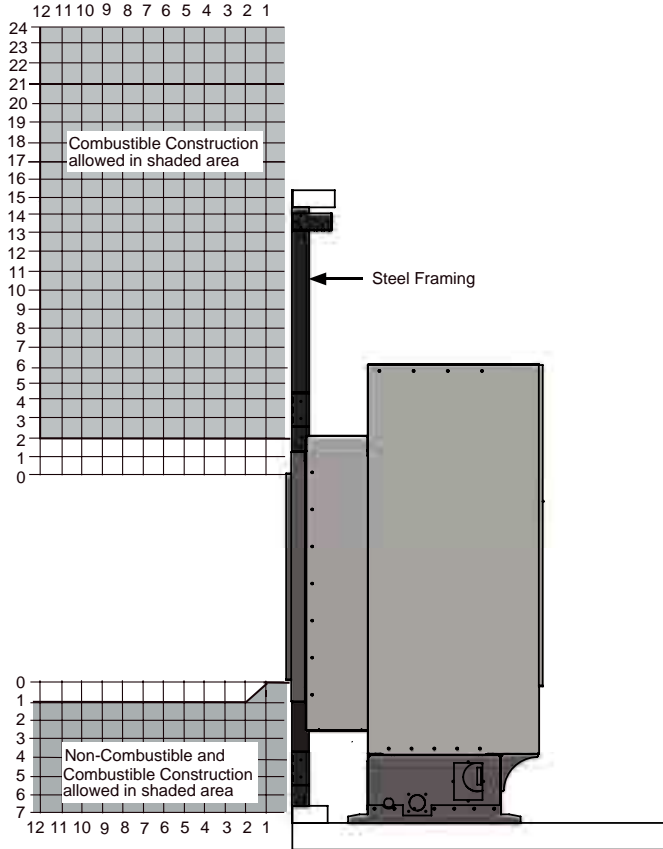

Figure 8. Combustible mantles and facings. (Not to scale)

Mantels & Surrounds

NOTE: National Canadian Gas Association mantel test requirements are for fire hazard prevention to combustible materials.

New technology, to meet consumer and government demands for the wise use of energy, has prompted us to manufacture many models of fireplaces which are hot, fuel and energy efficient.

Please be aware; temperatures over the mantel will rise above normal room temperature and walls above fireplace may be hot to touch.

We recommend careful consideration be given to the effects of elevated mantel temperatures which may be in excess of product design, for example: candles, plastic or pictures. This can cause melting, deformation, discolouration or premature failure of T.V. and radio components.

Side wall clearances are 6". Combustible surrounds may be installed with 6" clearance to the side of the fireplace as shown in **Figure 9**.

Allowable Sidewall Clearances

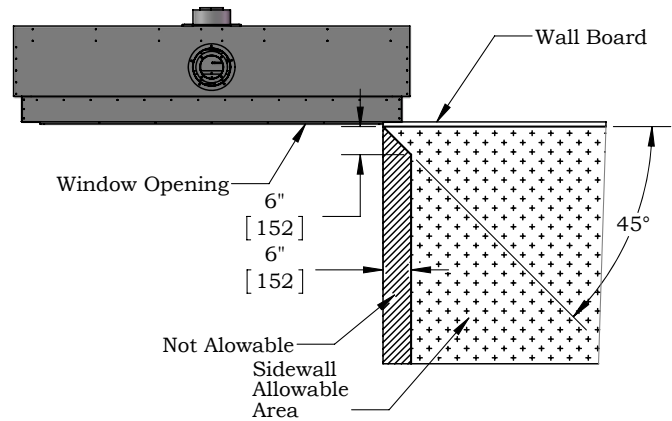

Figure 9. Combustible surrounds.

Installation



Section 4: Wiring

Installing the Fireplace Control Box

Install the Fireplace Control Box in an accessible location. The location should be where maintenance, adjustments and service may be made easily.

Installation of Electrical Supply

The RP620* is supplied with an external electrical control box pre-wired by the factory. The control box is connected to the fireplace with a 30 foot long 6-conductor cable that will communicate with the fireplace. Extension cables are available through your Montigo Dealer only.

A 20ft low voltage black / white cable is provided for connection to a single pole on/off switch. The length of this cable can be extended up to a length of 100ft using a cable of equal or greater capacity. This system operates on 24VAC. Do not connect this switch circuit to an external power source.

Optional remote control available through your Montigo Dealer.

Do not use third party remote controls without the approval from Montigo.

Installations in Canada must be electrically grounded in accordance with **CSA C22.1** Canadian Electrical Code Part 1 and/or Local Codes.

Installations in the USA must be electrically grounded in accordance with local codes or, in the absence of local codes, with the National Electrical Code, **ANSI/NFPA 70**.

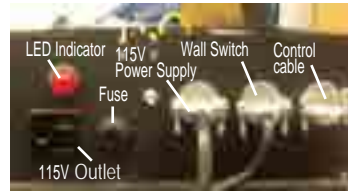

Left-side View



Right-side View

Figure 11. Control Box

Note: If any of the original wire supplied with the appliance is replaced, it must be with the same or its equivalent.

Conduit & Wiring clearances

Connect the power vent harness as outlined in the previous section. Ensure that the proper clearances are maintained for the wiring and conduit. When installing the wiring it must never run above the vent run and it must be at least 1" clear of all venting.

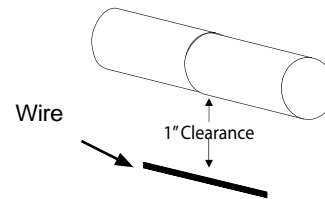

Figure 12. Conduit and Wiring

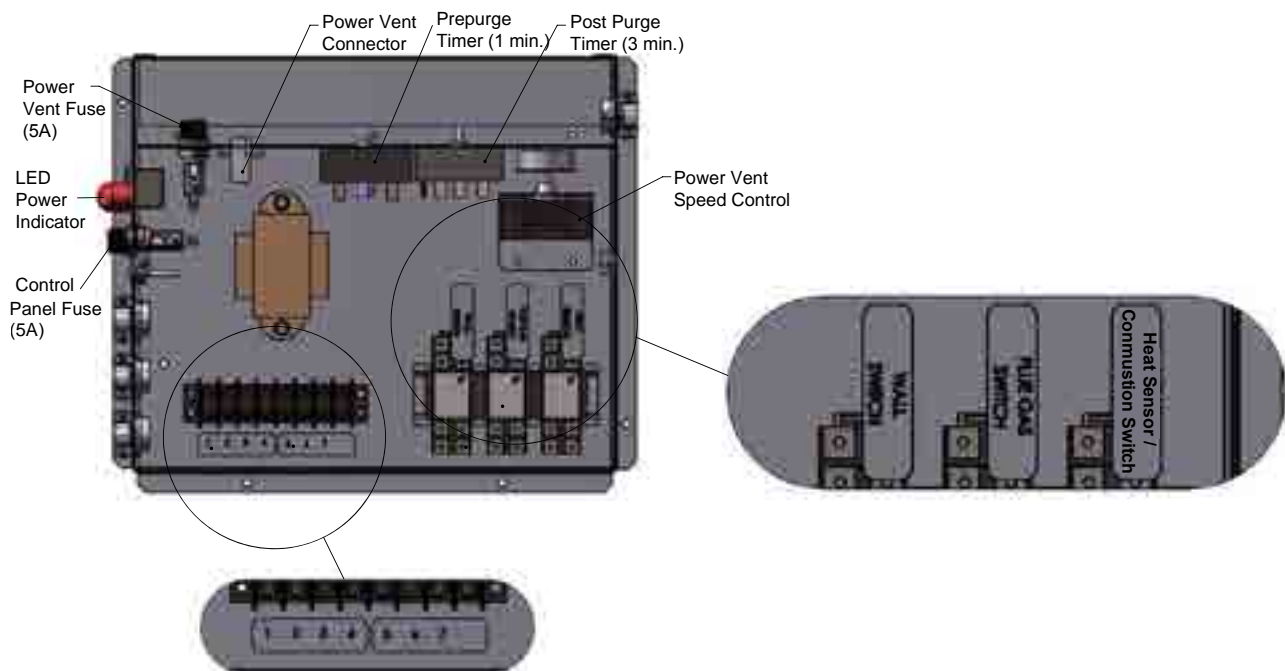

Figure 10. Control box Diagram



Installation

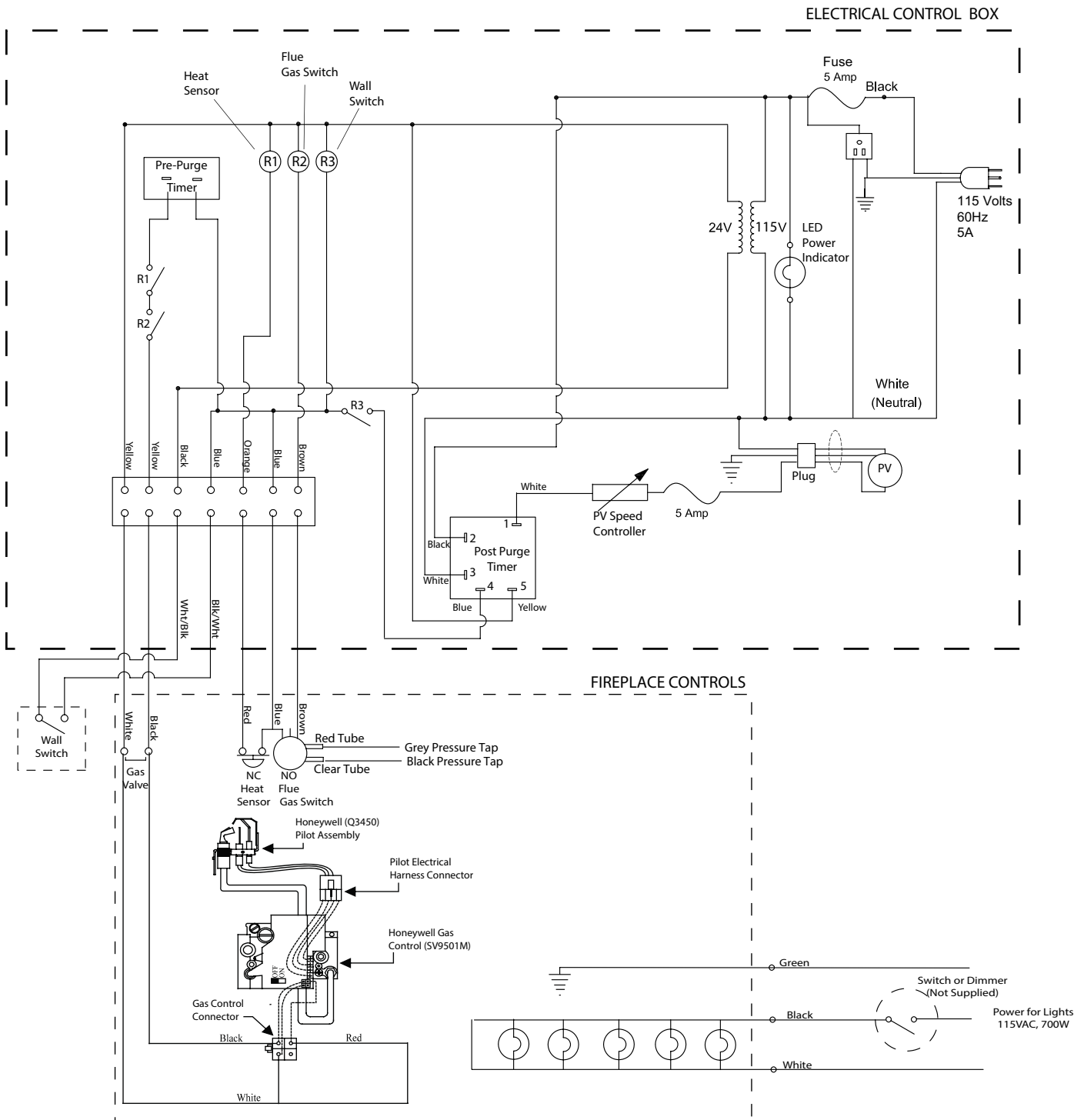

Figure 13. HSI Wiring Diagram

Installation



Section 5: Installing the gas line

Gas Pressure

Optimum appliance performance requires proper inlet pressures. Gas line sizing requirements will be determined in ANSI Z221.3 National Fuel Gas Code in the USA and CAN/CGAB149 in Canada.

Pressure requirements:

Pressure Requirements		
Gas Pressure	Natural Gas	Propane
Maximum Inlet Pressure	14" WC (1/2 psi)	14" WC (1/2 psi)
Minimum Inlet Pressure (with fireplace on)	5.5" W.C.	11" W.C.
Manifold Pressure	3.5" W.C. +/- 2	10" W.C. +/- 0.3

The manifold outlet pressure is set from the factory to the appropriate pressure but should be verified.

To check pressures, gas valves have a provision to remove a 1/8" MPT plug and to be fitted with a hose barb.

Montigo requires a service shut off valve be located in an accessible location to isolate the appliance.



Figure 14. Pressure Testing

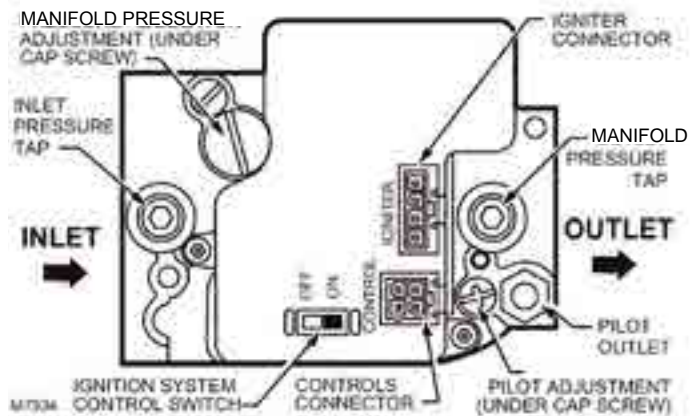

Figure 14a. HSI Valve

Only install gas shut-off valves approved for use by the state, province, or other governing body in which the fireplace is being installed.

GAS CONNECTION

See Figure 15 below for location of gas line access.

Flexible gas connectors must not exceed 3 feet in length, unless allowable within local regulations.

Connect incoming gas line to the 1/2" MPT gas inlet.

Purge all air out of gas line before connecting.

Check appliance connection, valve and valve train under normal operating pressure with a commercially available leak check solution.

DO NOT USE A FLAME OF ANY KIND TO TEST FOR LEAKS.

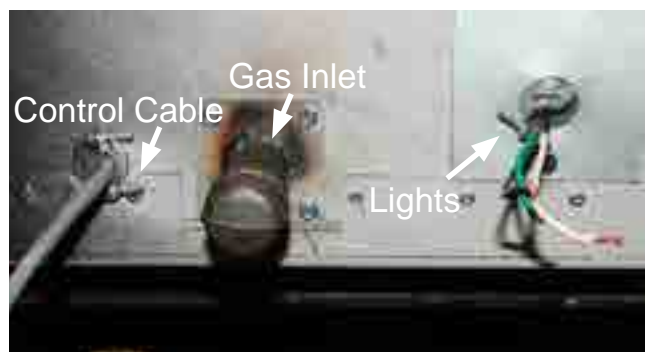

Figure 15. Identifying the Gas Inlet

⚠ DANGER

After gas line is connected, each appliance connection, valve and valve train **MUST** be checked while under normal operating pressure with either a Liquid Solution, or Leak Detection Device, to locate any source of leak. Tighten any areas where bubbling appears or a leak is detected until bubbling stops completely or leak is no longer detected. **DO NOT** use a flame of any kind to test for leaks. A fire or explosion will occur, causing serious injury, property damage or death.

NOTICE

When pressure testing the fireplace, Gas line, and input system follow the appropriate local codes for your area. **DO NOT** connect the fireplace to pressures in excess of 1/2 psi. This will damage the gas control valve.



Installation

Section 6: Venting Configuration for PVVEX58-300, PVHEX58-300 and PVHFL58-300

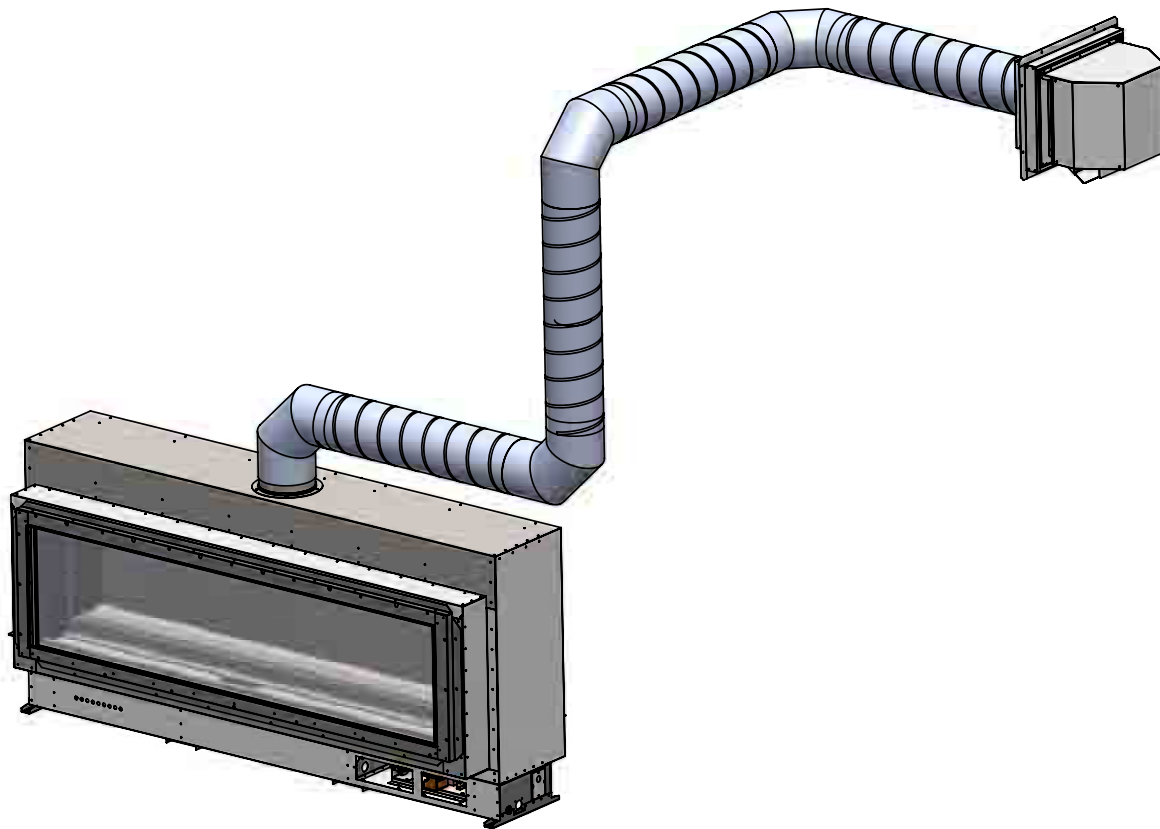

Vent configurations can include vertical sections, horizontal sections, elbows, flex and/or rigid vent sections. The maximum length of any vent run is 80'. Follow the rules outlined below to determine your specific vent options. All venting is to be 5" inner and 8" outer sizing. Because this appliance intended to only be installed with a power vent termination, vertical and horizontal runs can be calculated in the same manor.

Flexible venting does not flow quite as well as rigid pipe, so a factor needs to be applied, making the total allowable vent run shorter than rigid pipe.

Venting Calculation	Rigid Vent	Flex Venting
Maximum Vent Run - Rigid	80' total length	60' total length
90 degree elbow	subtract 10' each	* subtract 5' each
45 degree elbows	subtract 5' each	* subtract 2' each
Down sections	subtract 2' for every 1' down	subtract 2' for every 1' down
Flex Venting (if mixed with rigid)	Subtract 1.3' for every 1' section	

Figure 15. Venting Configuration

Installation



PVVEX58-300 Vertical Power Vent Detail

For installation instructions on this termination see instruction guide for the PVVEX58-300.

Not Acceptable

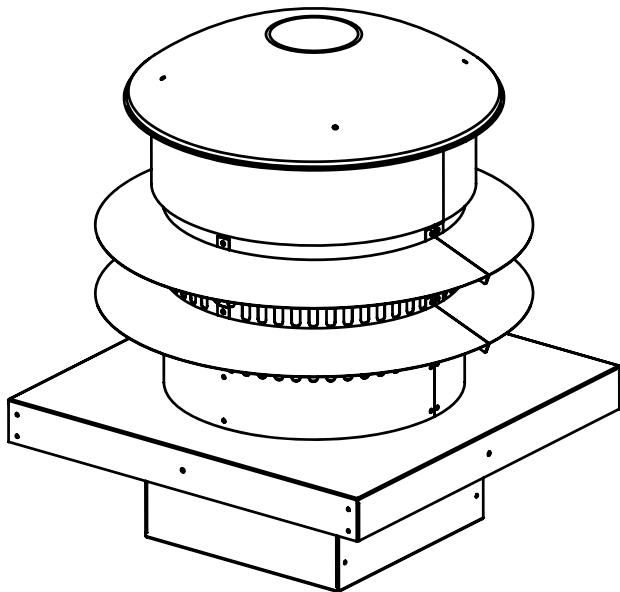

Figure 16. PVVEX58-300

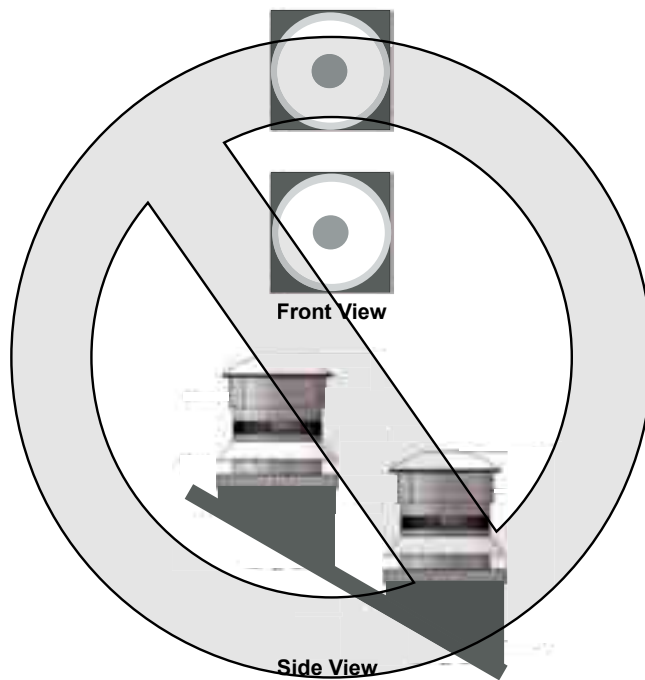

Figure 16b. PVVEX58-300 restrictions

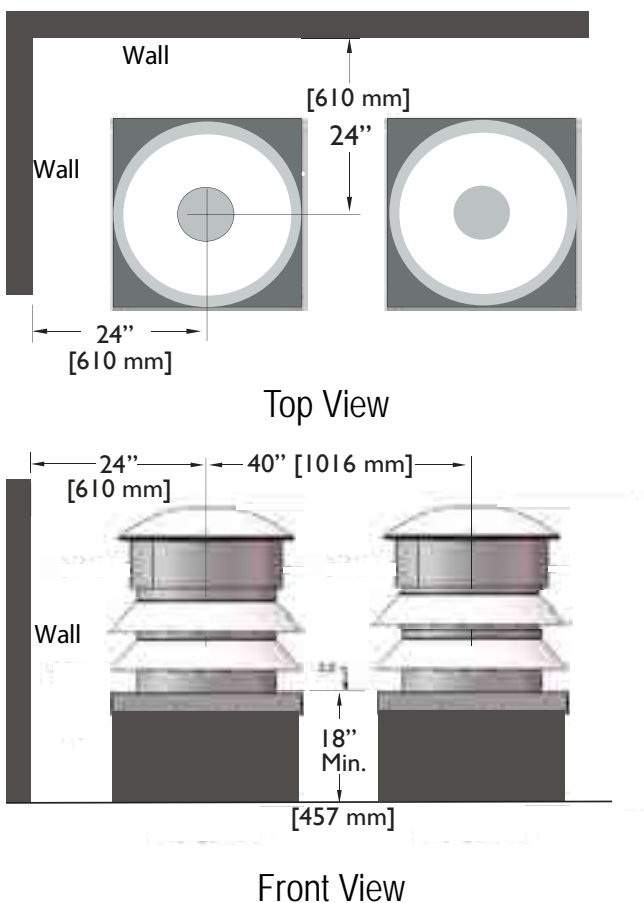
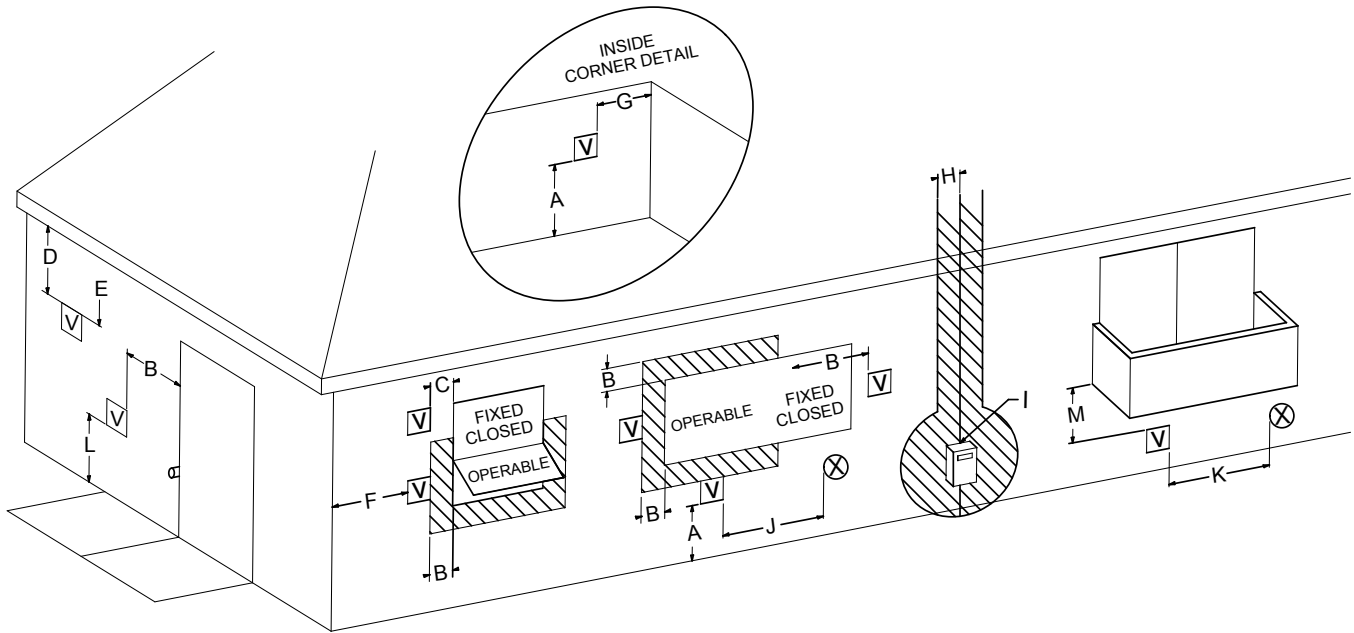

Figure 16a. PVVEX58-300 clearances



Installation

PVVEX58-300 Power Vent Locations



V VENTER TERMINAL
 X AIR SUPPLY INLET
 AREA WHERE TERMINAL IS NOT PERMITTED

	Canadian Installations ¹	US Installations ²
A= Clearance above grade, veranda, porch, deck, or balcony	12 in (30 cm)	12 in (30 cm)
B= Clearance to window or door that may be opened	6 in (15 cm) for appliances ≤ 10,000 Btuh (3 kW), 12 in (30 cm) for appliances > 10,000 Btuh (3 kW) and ≤ 100,000 Btuh (30 kW), 36 in (91 cm) for appliances > 100,000 Btuh (30 kW)	6 in (15 cm) for appliances ≤ 10,000 Btuh (3 kW), 9 in (23 cm) for appliances > 10,000 Btuh (3 kW) and < 50,000 Btuh (15 kW), 12 in (30 cm) for appliances ≥ 50,000 Btuh (15 kW)
C= Clearance to permanently closed window	B	B
D= Vertical clearance to ventilated soffit located above the terminal within a horizontal distance of 2 feet (61 cm) from the center line of the terminal	N/A	N/A
E= Clearance to unventilated soffit	*	*
F= Clearance to outside corner	*	*
G= Clearance to inside corner	*	*
H= Clearance to each side of center line extended above meter/regulator assembly	3 ft (91 cm) within a height 15 ft. (4.5 m) above the meter/regulator assembly	*
I= Clearance to service regulator vent outlet	3 ft (91 cm)	*

	Canadian Installations ¹	US Installations ²
J= Clearance to nonmechanical air supply inlet to building or the combustion air inlet to any other appliance	6 in (15 cm) for appliances ≤ 10,000 Btuh (3 kW), 12 in (30 cm) for appliances > 10,000 Btuh (3 kW) and ≤ 100,000 Btuh (30 kW), 36 in (91 cm) for appliances > 100,000 Btuh (30 kW)	6 in (15 cm) for appliances ≤ 10,000 Btuh (3 kW), 9 in (23 cm) for appliances > 10,000 Btuh (3 kW) and ≤ 50,000 Btuh (15 kW), 12 in (30 cm) for appliances > 50,000 Btuh (15 kW)
K= Clearance to a mechanical air supply inlet	6 ft (1.83 m)	3 ft (91 cm) above if within 10 ft (3 m) horizontally
L= Clearance above paved sidewalk or paved driveway located on public property	7 ft (2.13 m) †	*
M= Clearance under veranda porch deck, or balcony	12 in (30 cm) ‡	*

¹ In accordance with the current CSA B149.1, Natural Gas and Propane Installation Code
² In accordance with the current ANSI Z223.1/NFPA 54, National Fuel Gas Code
 † A vent shall not terminate directly above a sidewalk or paved driveway that is located between two single family dwellings and serves both dwellings.
 ‡ Permitted only if veranda, porch, deck, or balcony is fully open on a minimum of two sides beneath the floor.
 * For clearances not specified in ANSI Z223.1/NFPA or CSA B149.1, one of the following shall be indicated:
 a) A minimum clearance value determined by testing in accordance with section 2.23.5, or;
 b) A reference to the following footnote:
 "Clearance in accordance with local installation codes and the requirements of the gas supplier"

Installation



PVHEX58-300 Horizontal Power Vent Detail

For installation instructions on this termination see instruction guide for the PVHEX58-300.

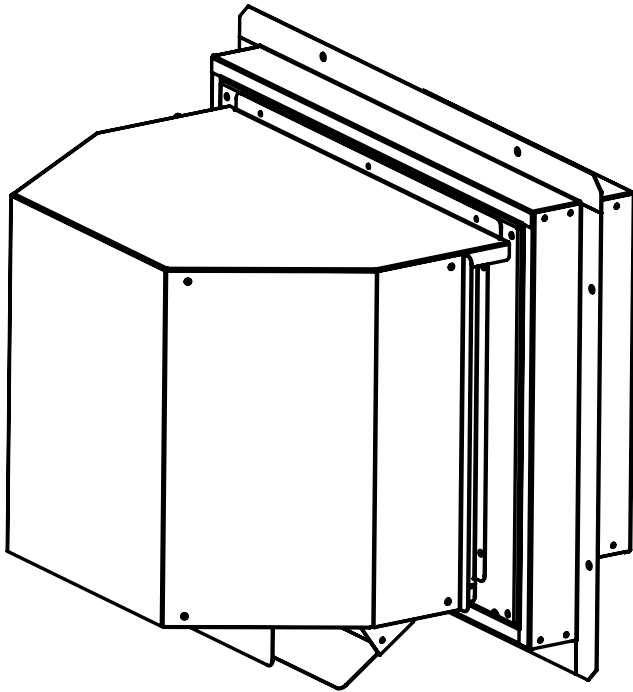
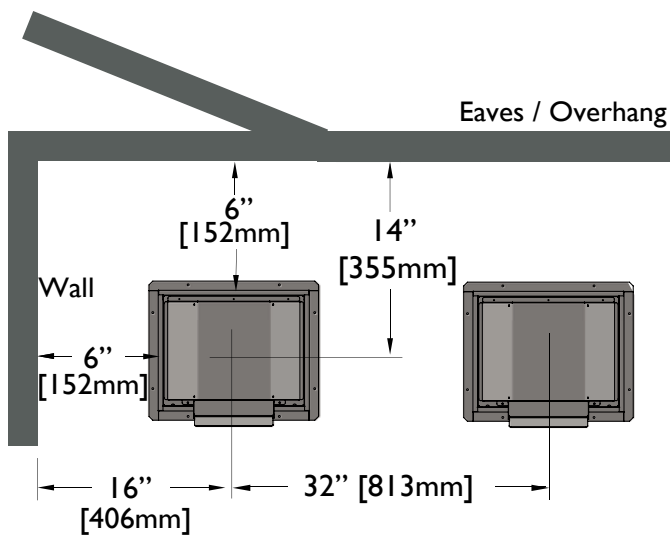

Figure 17. PVHEX58-300



Side View

Figure 17a. PVHEX58-300 Termination Clearances



Installation

PVHEX58-300 Power Vent Locations

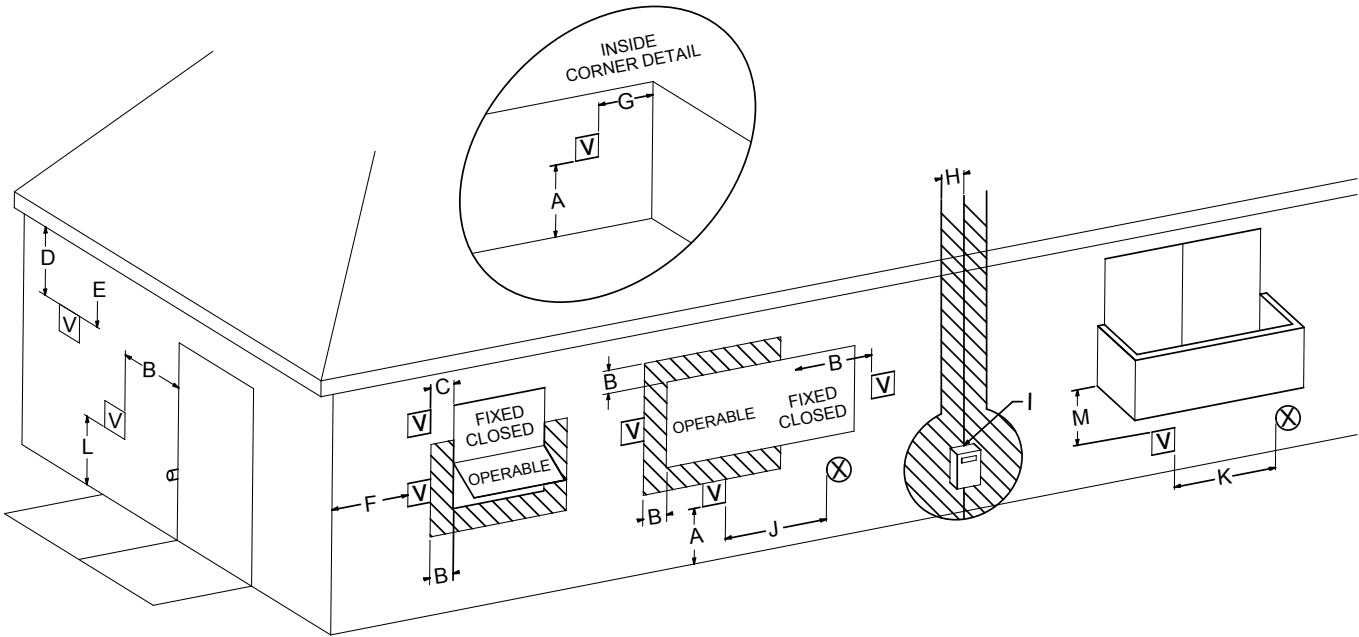

V VENTER TERMINAL
 X AIR SUPPLY INLET
 AREA WHERE TERMINAL IS NOT PERMITTED

	Canadian Installations ¹	US Installations ²
A= Clearance above grade, veranda, porch, deck, or balcony	12 in (30 cm)	12 in (30 cm)
B= Clearance to window or door that may be opened	6 in (15 cm) for appliances ≤ 10,000 Btuh (3 kW), 12 in (30 cm) for appliances > 10,000 Btuh (3 kW) and ≤ 100,000 Btuh (30 kW), 36 in (91 cm) for appliances > 100,000 Btuh (30 kW)	6 in (15 cm) for appliances ≤ 10,000 Btuh (3 kW), 9 in (23 cm) for appliances > 10,000 Btuh (3 kW) and < 50,000 Btuh (15 kW), 12 in (30 cm) for appliances ≥ 50,000 Btuh (15 kW)
C= Clearance to permanently closed window	B	B
D= Vertical clearance to ventilated soffit located above the terminal within a horizontal distance of 2 feet (61 cm) from the center line of the terminal	6 in (15 cm)	6 in (15 cm)
E= Clearance to unventilated soffit	6 in (15 cm)	6 in (15 cm)
F= Clearance to outside corner	6 in (15 cm)	6 in (15 cm)
G= Clearance to inside corner	6 in (15 cm)	6 in (15 cm)
H= Clearance to each side of center line extended above meter/regulator assembly	3 ft (91 cm) within a height 15 ft. (4.5 m) above the meter/regulator assembly	*
I= Clearance to service regulator vent outlet	3 ft (91 cm)	*

	Canadian Installations ¹	US Installations ²
J= Clearance to nonmechanical air supply inlet to building or the combustion air inlet to any other appliance	6 in (15 cm) for appliances ≤ 10,000 Btuh (3 kW), 12 in (30 cm) for appliances > 10,000 Btuh (3 kW) and ≤ 100,000 Btuh (30 kW), 36 in (91 cm) for appliances > 100,000 Btuh (30 kW)	6 in (15 cm) for appliances ≤ 10,000 Btuh (3 kW), 9 in (23 cm) for appliances > 10,000 Btuh (3 kW) and ≤ 50,000 Btuh (15 kW), 12 in (30 cm) for appliances > 50,000 Btuh (15 kW)
K= Clearance to a mechanical air supply inlet	6 ft (1.83 m)	3 ft (91 cm) above if within 10 ft (3 m) horizontally
L= Clearance above paved sidewalk or paved driveway located on public property	7 ft (2.13 m) †	*
M= Clearance under veranda porch, deck, or balcony	12 in (30 cm) ‡	*

¹ In accordance with the current CSA B149.1, Natural Gas and Propane Installation Code
² In accordance with the current ANSI Z223.1/NFPA 54, National Fuel Gas Code
 † A vent shall not terminate directly above a sidewalk or paved driveway that is located between two single family dwellings and serves both dwellings.
 ‡ Permitted only if veranda, porch, deck, or balcony is fully open on a minimum of two sides beneath the floor.
 * For clearances not specified in ANSI Z223.1/NFPA or CSA B149.1, one of the following shall be indicated
 a) A minimum clearance value determined by testing in accordance with section 2.23.5, or;
 b) A reference to the following footnote:
 "Clearance in accordance with local installation codes and the requirements of the gas supplier"

Installation



PVHFL58-300 Horizontal Power Vent Detail

For installation instructions on this termination see instruction guide for the PVHFL58-300.

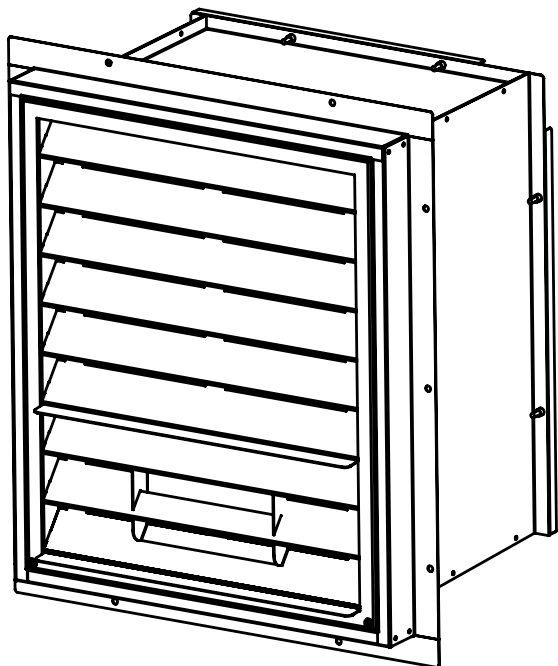

Figure 18. PVHFL58-300

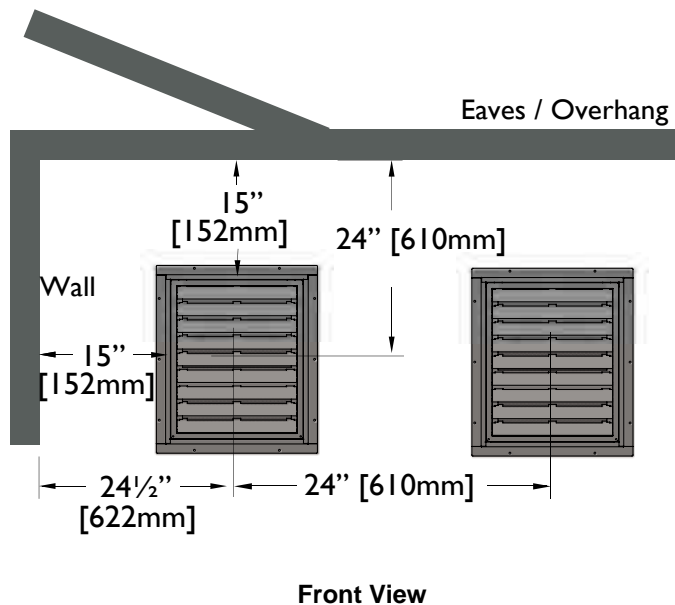
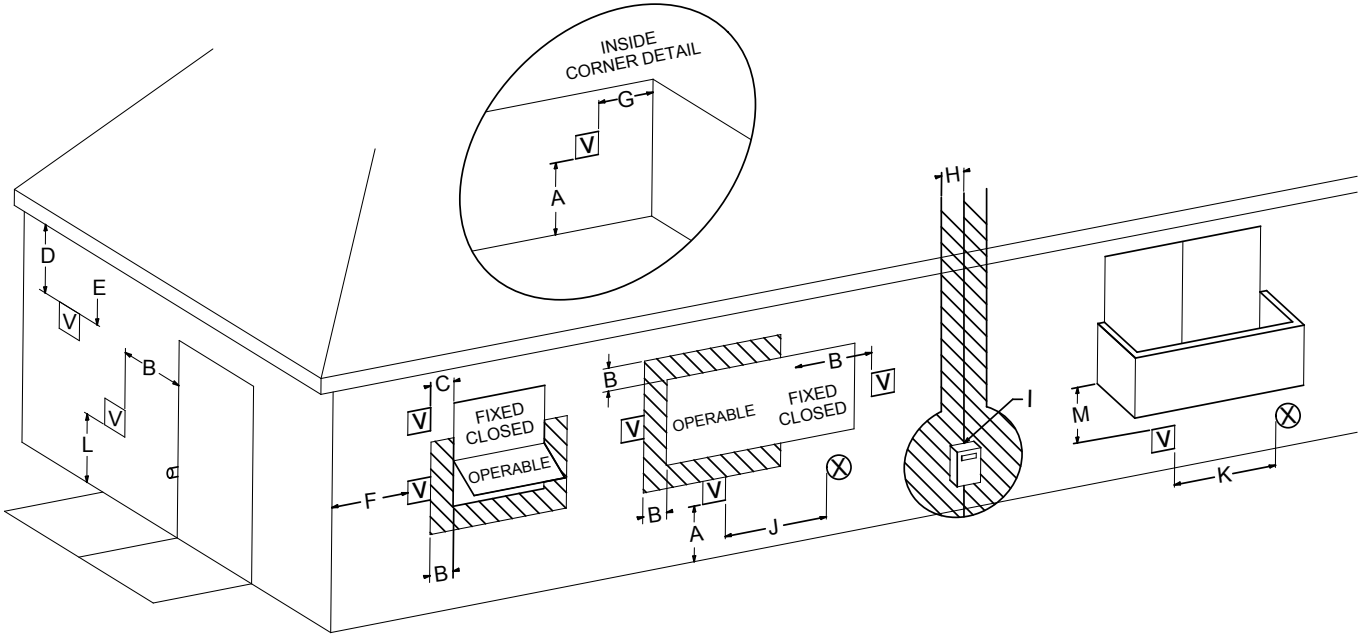

Figure 18a. PVHFL58-300 Termination Clearances



Installation

PVHFL58-300 Power Vent Locations



V VENTER TERMINAL
 X AIR SUPPLY INLET
 ▨ AREA WHERE TERMINAL IS NOT PERMITTED

	Canadian Installations ¹	US Installations ²
A= Clearance above grade, veranda, porch, deck, or balcony	12 in (30 cm)	12 in (30 cm)
B= Clearance to window or door that may be opened	6 in (15 cm) for appliances ≤ 10,000 Btuh (3 kW), 12 in (30 cm) for appliances > 10,000 Btuh (3 kW) and ≤ 100,000 Btuh (30 kW), 36 in (91 cm) for appliances > 100,000 Btuh (30 kW)	6 in (15 cm) for appliances ≤ 10,000 Btuh (3 kW), 9 in (23 cm) for appliances > 10,000 Btuh (3 kW) and < 50,000 Btuh (15 kW), 12 in (30 cm) for appliances ≥ 50,000 Btuh (15 kW)
C= Clearance to permanently closed window	B	B
D= Vertical clearance to ventilated soffit located above the terminal within a horizontal distance of 2 feet (61 cm) from the center line of the terminal	15 in (38 cm)	15 in (38 cm)
E= Clearance to unventilated soffit	15 in (38 cm)	15 in (38 cm)
F= Clearance to outside corner	6 in (15 cm)	6 in (15 cm)
G= Clearance to inside corner	15 in (38 cm)	15 in (38 cm)
H= Clearance to each side of center line extended above meter/regulator assembly	3 ft (91 cm) within a height 15 ft. (4.5 m) above the meter/regulator assembly	*
I= Clearance to service regulator vent outlet	3 ft (91 cm)	*

	Canadian Installations ¹	US Installations ²
J= Clearance to nonmechanical air supply inlet to building or the combustion air inlet to any other appliance	6 in (15 cm) for appliances ≤ 10,000 Btuh (3 kW), 12 in (30 cm) for appliances > 10,000 Btuh (3 kW) and ≤ 100,000 Btuh (30 kW), 36 in (91 cm) for appliances > 100,000 Btuh (30 kW)	6 in (15 cm) for appliances ≤ 10,000 Btuh (3 kW), 9 in (23 cm) for appliances > 10,000 Btuh (3 kW) and ≤ 50,000 Btuh (15 kW), 12 in (30 cm) for appliances > 50,000 Btuh (15 kW)
K= Clearance to a mechanical air supply inlet	6 ft (1.83 m)	3 ft (91 cm) above if within 10 ft (3 m) horizontally
L= Clearance above paved sidewalk or paved driveway located on public property	7 ft (2.13 m) †	*
M= Clearance under veranda porch deck, or balcony	12 in (30 cm) ‡	*

¹ In accordance with the current CSA B149.1, Natural Gas and Propane Installation Code
² In accordance with the current ANSI Z223.1/NFPA 54, National Fuel Gas Code
 † A vent shall not terminate directly above a sidewalk or paved driveway that is located between two single family dwellings and serves both dwellings.
 ‡ Permitted only if veranda, porch, deck, or balcony is fully open on a minimum of two sides beneath the floor.
 * For clearances not specified in ANSI Z223.1/NFPA or CSA B149.1, one of the following shall be indicated
 a) A minimum clearance value determined by testing in accordance with section 2.23.5, or;
 b) A reference to the following footnote:
 "Clearance in accordance with local installation codes and the requirements of the gas supplier"

Installation



Section 7: Venting Configuration for PVHIN58-300 with TMHIN58-40

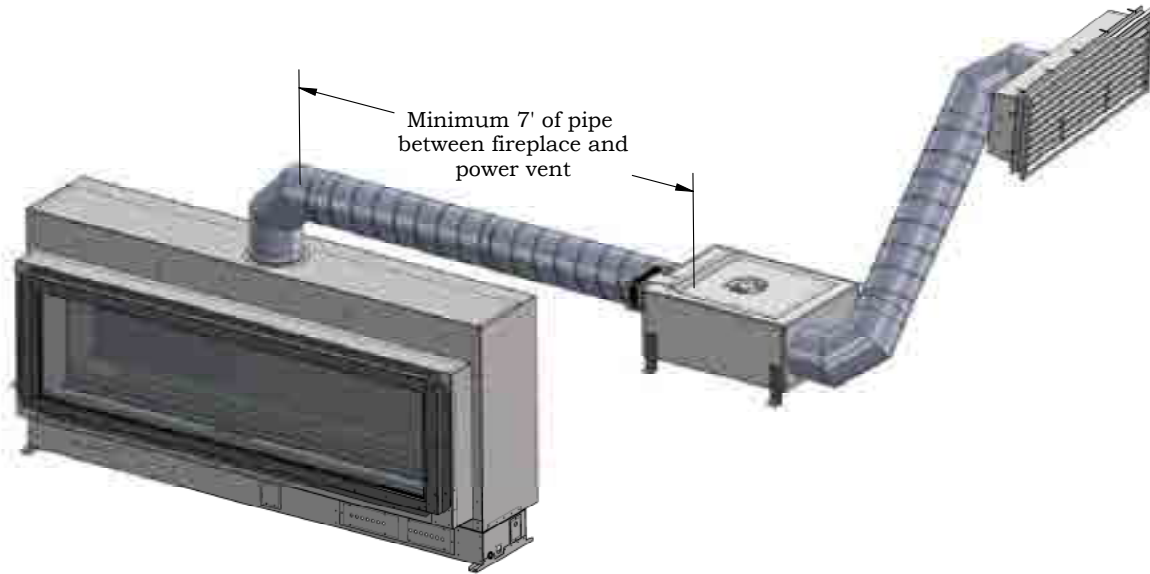

Vent configurations can include vertical sections, horizontal sections, elbows, flex and/or rigid vent sections. The maximum length of any vent run is 50'. Follow the rules outlined below to determine your specific vent options. All venting is to be 5" inner and 8" outer sizing. Because this appliance is intended to only be installed with a power vent termination, vertical and horizontal runs can be calculated in the same manner.

Flexible venting does not flow quite as well as rigid pipe, so a factor needs to be applied, making the total allowable vent run shorter than rigid pipe.

Venting Calculation	Rigid Vent	Flex Venting
Maximum Vent Run - Rigid	50' total length	40' total length
90 degree elbow	subtract 10' each	* subtract 5' each
45 degree elbows	subtract 5' each	* subtract 2' each
Down sections	subtract 2' for every 1' down	subtract 2' for every 1' down
Flex Venting (if mixed with rigid)	Subtract 1.3' for every 1' section	

* Not for rigid elbows used in between flex sections

Figure 19. Venting Configuration



Installation

PVHIN58-300 Inline Power Vent with TMHIN58-40 Detail

For installation instructions on this power vent and termination see instruction guide for the PVHIN58-300 with TMHIN58-40.

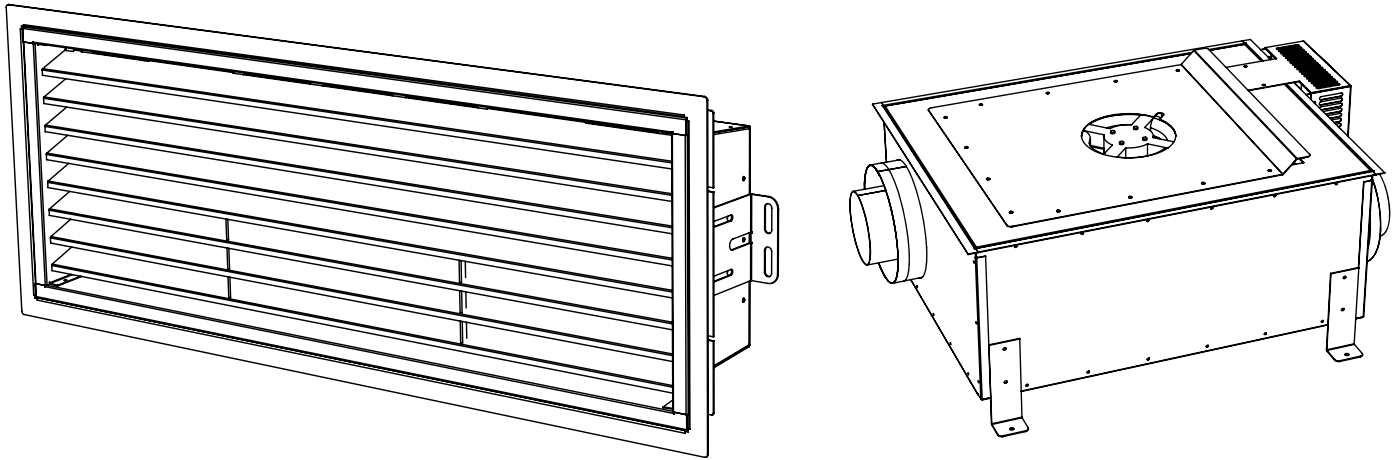

Figure 20. PVHIN58-300 Inline power vent with TMHIN58-40 Termination (with vanity ring)

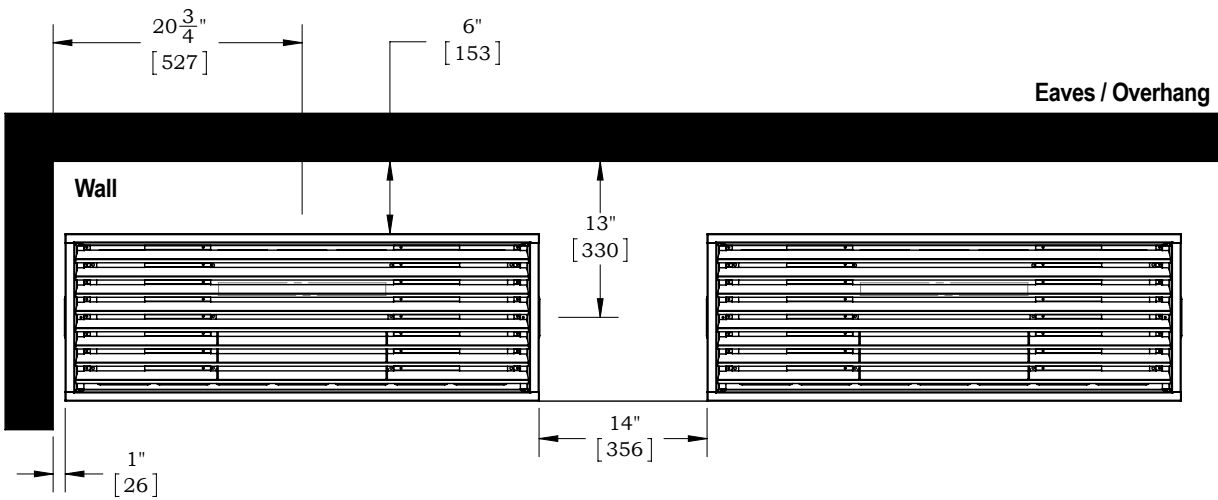

Figure 20a. TMHIN58-40 Termination Clearances (without vanity ring)

Note: There is enough clearance in the above clearances drawing to allow for a vanity ring to be added on at a later time.

Installation



PVHIN58-300 Inline Power Vent with TMHIN58-40 Termination Locations

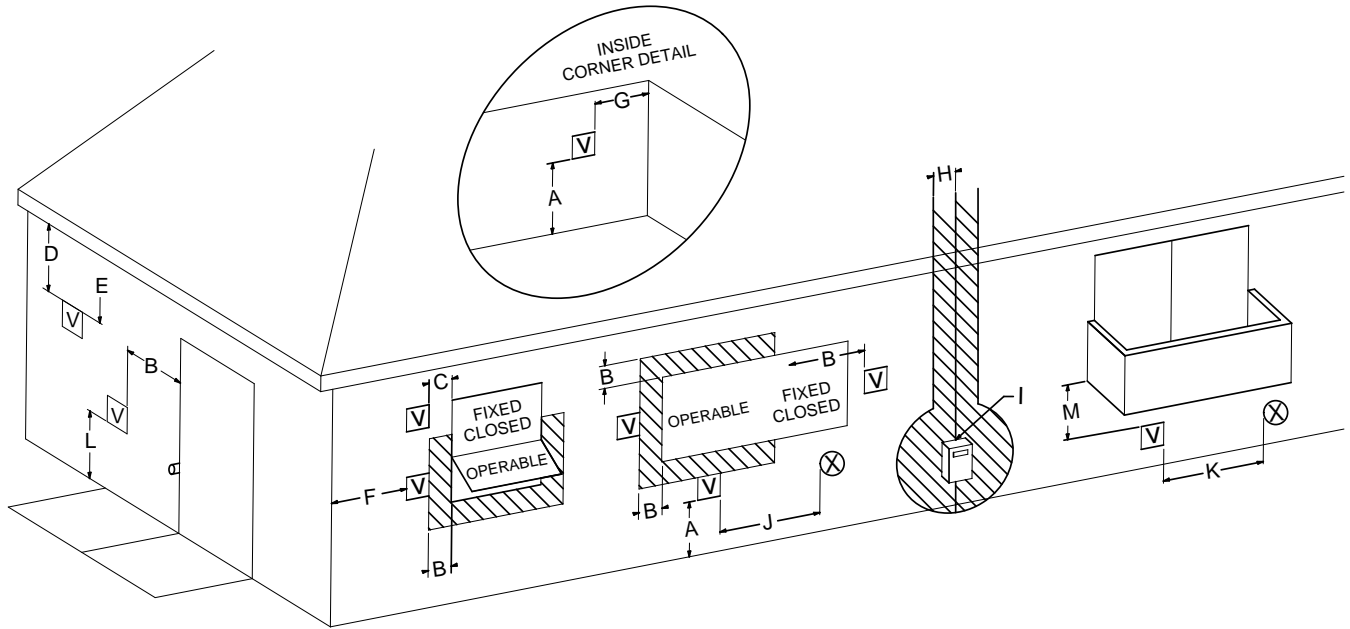

VENTER TERMINAL

AIR SUPPLY INLET

AREA WHERE TERMINAL IS NOT PERMITTED

	Canadian Installations ¹	US Installations ²
A= Clearance above grade, veranda, porch, deck, or balcony	12 in (30 cm)	12 in (30 cm)
B= Clearance to window or door that may be opened	6 in (15 cm) for appliances ≤ 10,000 Btuh (3 kW), 12 in (30 cm) for appliances > 10,000 Btuh (3 kW) and ≤ 100,000 Btuh (30 kW), 36 in (91 cm) for appliances > 100,000 Btuh (30 kW)	6 in (15 cm) for appliances ≤ 10,000 Btuh (3 kW), 9 in (23 cm) for appliances > 10,000 Btuh (3 kW) and < 50,000 Btuh (15 kW), 12 in (30 cm) for appliances ≥ 50,000 Btuh (15 kW)
C= Clearance to permanently closed window	B	B
D= Vertical clearance to ventilated soffit located above the terminal within a horizontal distance of 2 feet (61 cm) from the center line of the terminal	6 in (38 cm)	6 in (38 cm)
E= Clearance to unventilated soffit	6 in (38 cm)	6 in (38 cm)
F= Clearance to outside corner	* (15 cm)	* (15 cm)
G= Clearance to inside corner	0 in (38 cm)	0 in (38 cm)
H= Clearance to each side of center line extended above meter/regulator assembly	3 ft (91 cm) within a height 15 ft. (4.5 m) above the meter/regulator assembly	*
I= Clearance to service regulator vent outlet	3 ft (91 cm)	*

	Canadian Installations ¹	US Installations ²
J= Clearance to nonmechanical air supply inlet to building or the combustion air inlet to any other appliance	6in (15 cm) for appliances ≤ 10,000 Btuh (3 kW), 12 in (30 cm) for appliances > 10,000 Btuh (3 kW) and ≤ 100,000 Btuh (30 kW), 36 in (91 cm) for appliances > 100,000 Btuh (30 kW)	6in (15 cm) for appliances ≤ 10,000 Btuh (3 kW), 9 in (23 cm) for appliances > 10,000 Btuh (3 kW) and ≤ 50,000 Btuh (15 kW), 12 in (30 cm) for appliances > 50,000 Btuh (15 kW)
K= Clearance to a mechanical air supply inlet	6 ft (1.83 m)	3 ft (91 cm) above if within 10 ft (3 m) horizontally
L= Clearance above paved sidewalk or paved driveway located on public property	7 ft (2.13 m) †	*
M= Clearance under veranda porch deck, or balcony	12 in (30 cm) ‡	*

¹ In accordance with the current CSA B149.1, Natural Gas and Propane Installation Code

² In accordance with the current ANSI Z223.1/NFPA 54, National Fuel Gas Code

† A vent shall not terminate directly above a sidewalk or paved driveway that is located between two single family dwellings and serves both dwellings.

‡ Permitted only if veranda, porch, deck, or balcony is fully open on a minimum of two sides beneath the floor.

* For clearances not specified in ANSI Z223.1/NFPA or CSA B149.1, one of the following shall be indicated

a) A minimum clearance value determined by testing in accordance with section 2.23.5, or;

b) A reference to the following footnote:

"Clearance in accordance with local installation codes and the requirements of the gas supplier"



Installation

Venting components

The following components and associated Montigo part numbers are for installation of a roof or wall mounted Power Vent. **Only use Montigo Vent Components.** Use of non-Montigo parts will **VOID** the warranty and may impede operation of the fireplace.

A - Termination with Frame Kit	PVEX58-300 (Roof Mount 5"/8") PVH58-300 (Wall Mount 5"/8") PVHFL58-300 (Flush Wall Mount 5"/8") PVHIN58-300 Inline Power Vent with TMHIN58-40 termination
B - Flex Sections	PFL1 (12" f/f Section) PFL2 (24" f/f Section) PFL3 (36" f/f Section) PFL4 (48" f/f Section) PFL6 (72" f/f Section)
C - Rigid Sections	PXT - 10 (10" f/f Section) PXT - 20 (20" f/f Section) PEXT - 1 (12" f/m Section) PEXT - 2 (24" f/m Section) PEXT - 3 (36" f/m Section) PEXT - 4 (48" f/m Section) PEXT - 6 (72" f/m Section)
D - Elbows	PEL-90MM (m/m 90° Elbow) PEL-90FF (f/f 90° Elbow) PEL-90FM (f/m 90° Elbow) PEL-45FM (f/m 45° Elbow)
E - Support Ring & Plate	RSPXT-8
F - Firestop	FS-8
G - Heat Shield	RHS101

Montigo supplies a variety of power venting options. The location of the power vent should be selected and laid out to provide the most efficient possible run to an external wall or through the roof.

Notes For Planning Venting:

- RP-Series fireplaces are Power Vent Designated and use Montigo's 5/8 vent pipes.
- Venting originates from the top or rear of the unit.
- Venting can terminate through the roof or exterior wall.
- For a detailed diagram of allowed termination locations, see pages 22, 24, or 26.
- Once the termination location has been established refer to the appropriate section for installation details.
- All fireplaces are shipped Top Vent from the factory.
- Follow the chart on page 20 for maximum vent run and maximum elbows.

Connection and installation of the vent components should adhere to the following guidelines:

- Use any combination of rigid and flex pipe as required and in any orientation (Male connectors can face in any direction).
- Flex sections may be stretched up to 50% of their total length (e.g. a 24" section maybe stretched to 36").
- Ensure the pipe ends male to female slide in a minimum of 1 1/2" of overlap.
- Connect all vent sections using a minimum of three sheet metal screws on the outer pipe flue.
- Ensure all runs are supported with a minimum of 3 supports per 10' of venting.
- When hanging/ supporting venting, ensure that 1" clearance is maintained on sides and bottom of vent runs and 2" above horizontal vent runs to any combustible material.
- Rigid pipe may be cut less than half way from the **female end only.**
- Ensure when cutting sections of rigid pipe to maintain integrity of internal supports.
- Place the springs, supplied with the pipe kit, between the outer and inner pipes to keep the pipes separate and avoid any possible hot spots.
- Montigo recommends the use of a flex section for the final pipe connected directly to the fireplace offering greater flexibility of installation and absorption of movement.
- Firestops must be installed as required by National & local codes.
- When passing vent pipe through a wall use a heat shield.
- Montigo recommends that all exterior corners and joints be sealed with exterior caulking. However, we encourage you to consult your Building Envelope Engineer or Waterproofing Consultant for further recommendations.

IMPORTANT:
Please Refer to your Building Envelope Engineer or Waterproofing Consultant for a review of ALL penetrations through exterior walls or the roof.

Installation



Section 8: Testing the System

The **RP620*** Control and Power Vent System can be safely tested prior to finishing the fireplace enclosure. This test can be done quickly and efficiently to ensure all systems function according to the design specifications.

- Connect two 1/8" MPT hose barb fittings to the gas valve inlet and outlet ports, as shown in **figure 14**. Connect a 0-16" W.C. manometer to each fitting.
- Turn on the gas supply to the appliance.
- Wait 3 minutes and check for any gas leaks. If you smell or detect a gas leak, turn the gas supply off and take corrective actions.
- Turn supply power on.
- The LED power indicator will be illuminated.
- Install the inner window, light tray glass, and outer window (see appropriate sections).
- Place the appliance in operation. See the lighting instructions on **page 37**.
- Once the appliance is operational, confirm the manifold pressure and supply pressure are within the specified limits, see **section 5**.
- Turn lights on and confirm all lights are working.



Figure 21. LED Indicators



Installation

Section 9: Removing / Installing the Safety Screen and Inner/Outer Windows

Removing the screen:

There are two tabs located at either end of the screen bottom. By grasping these tabs lift the screen upward into the upper track. Once the screen has cleared the boom track, pull the bottom of the screen away and downwards from the unit to remove the screen from the upper track.



Figure 22.



Figure 22a.

Removing the outer window:



Figure 23.

Step 1:

Grasp the trim on either side of the door with the tips of your fingers. *(Both sides Typ.)* Pull firmly to remove the trim from the fireplace.

Step 2:

Then, pull the trim from the top of the door, as shown.



Figure 24.

Step 3:

Remove the trim from the bottom of the door as shown.

Step 4:

Remove the other side, as shown in Steps 1 - 3.

Installation



Inner Window:

Follow the steps to remove, or install the **RP620*** fireplace window.



Figure 25.

Step 1:

Remove glass suction cups from box and place on Glass panel. (The tool may not be exactly as shown).

Step 2:

Place the suction cups on the outer glass panel, spaced evenly. **(Ensure they are firmly attached, and secured.)**



Figure 26.

Step 3: Lifting the glass panel.

Hold the Tools firmly and lift the glass panel up and out of the lower track (Into the upper track). Tilt the lower edge of the glass panel outwards.



Figure 27.

Step 4:

Ensure the top edge of the glass panel is fully removed from the upper outer track. Then tilt and lift away cautiously from the fireplace. Store in a safe location.

Step 5:

Attach suction cups on the inner glass door. Remove the four inner glass retainers at the top of the glass, see figure for glass retainer placement.

Caution: keep at least one hand on suction cup attached to the inner glass when removing the last glass retainer. Glass could fall forward and break if not secure.



Figure 28.



Figure 29.

Step 6:

Lean the inner glass door towards you from the top of the glass. Lift inner glass door up and out. Be careful not to impact the glass door against metal as it could cause the glass to chip.



Figure 30.



Installation

Section 10: Installing Accessories

Firestone / Fireglass Installation

The RP620* is supplied with eight 3 lbs bags of glass firestones. Once the trim and glass door is removed, place the firestones randomly around the burners as shown in **Figures 23 and 23a**. Fireglass installation is the same as firestones.

Note: DO NOT cover the pilot with firestones or any other media.



Figure 31. Place one layer of firestones in burner tray



Figure 31a. Do not place any firestones on top of the pilot cover.

Optional Speckled Stones

The RP620* has the option of installing the Speckled Stones which mimic real stone. These may be spaced evenly across the burner and/or light tray. See the Montigo web site for photographs and ideas.

www.montigo.com

The RP620* requires 2 sets of Speckled Stones (RR150SS) to cover the burner and an additional 2 sets to cover the light tray.

Note: DO NOT cover the pilot with Speckled Stones or any other media.

NOTICE

Do not operate this fireplace without the glass doors or with a broken glass door.



Figure 31b. Completed firestone installation

Installation



Optional Log Set

The RP620* has the option of installing a drift wood log set. Once the firestones have been installed the log set can be installed.

Ensure logs are securely placed and will not tip or fall. Remove beads where logs touch the burner tray to ensure a more secure position.

Lean the logs against the back panels. **NO LOGS SHOULD LAY ACROSS OR OVER TOP OF THE BURNER PORTS ON THE SURFACE OF THE BURNER.**

RP620N-I Log Kit Installation

Log kits used to create sequence shown: 1 LGS57, 2 LGS58, 1 LGS59

Step 1: Remove both logs in kit LGS57. Both logs are identical.



Figure 32.
Place each log in the location shown in figure 24a . Use the porcelain panel joints as reference. The logs should be behind the burner ports and leaning against the porcelain panel.



Figure 32a.



Figure 32b.
The log placed on the right should be orientated 180° compared to the left log.



Figure 32c.

Step 2: Identify logs in kit LGS58



Figure 32d.
Place Log 1 behind the burner port next to the right log of LGS57. . Place log 2 on top of log 1. see figure 24e.



Figure 32e.



Figure 32f.
Step 3: Place log 1 from the second LGS58 kit in front of the ports left of the log from LGS57, see figure 24g.



Figure 32g.
Take log 3 from each LGS58. place one in front of the ports near the middle of the appliance, see figure 24f. Place the other in front of the ports and pilot, see figure 24g.



Installation



Figure 32h.



Figure 32i.



Figure 32j.

Step 3: From LGS58, place log 4 on the left side of the left log from LGS57. Cross log 4 over the ports. Place log 5 on the right side of the left log from LGS57. Cross log 5 over the ports. See figure 24k.



Figure 32k.

From LGS58, Place log 4 on the right log from LGS57. Cross log 4 over the ports. Place log 2 on the right end of the right log from LGS57, See Figure 24l.



Figure 32L.



Figure 32m.

Step 5: From LGS58, Place log 5 on top of the end of the right log from LGS57 and cross the burner to log 3, see figure 24m. Place log 6 on top of the end of log 2 and cross the burner to log 3 see figure 24n.

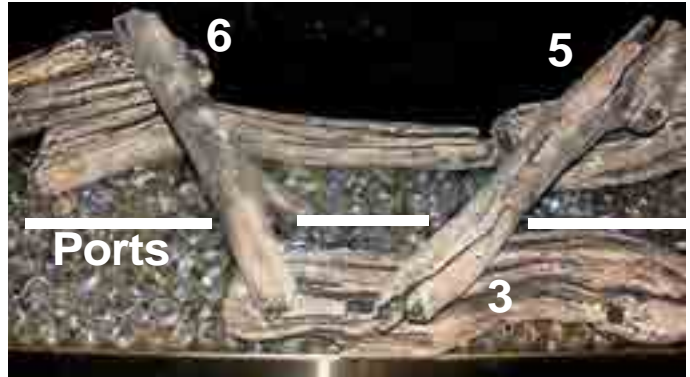

Figure 32n



Figure 32o.

Step 6: Place log 6 from LGS58 on top of log 1 near the middle of the burner. Cross log 6 on top p of the first log 6 installed in step 5. See figure 24p.



Figure 32p.

Installation



Step 7: Place the logs from LGS59 in any configuration you find pleasing over top of the light tray. Be sure to install the inner glass first.



Figure 32q.



Figure 32r.



Installation

The RP620* has the option of installing a drift wood log set. Once the firestones have been installed, figures , you can begin installing the log set by following the steps below, figures .

NO LOGS SHOULD IMPEDE THE FLAME, sooting may occur.

RP620L-I

Log kits used to create sequence shown: 1 LGS57, 1 LGS58, 1 LGS59

Step 1: Remove both logs in kit LGS57. Both logs are identical.



Figure 33.
Place each log in the location shown in figure 25a. Use the porcelain panel joints as reference. The logs should be behind the burner ports and leaning against the porcelain panel.



Figure 33a.



Figure 33b.
The log placed on the right should be orientated 180° compared to the left log.



Figure 33c.

Step 2: Identify logs in kit LGS58



Figure 33d.
Place Log 5 on the left end of the left log from LGS57. Keep log 5 away from the ports, See figure 25e for placement.



Figure 33e.



Figure 33f.
Step 3: From LGS58, place log 3 in front of the ports and pilot. Place log 2 on the right end of the right log from LGS57. Keep log 2 away from the ports. See figure 25g.



Figure 33g.



Figure 33h.
Step 4: From LGS58 place log 1 behind the ports in the middle of the burner, see figure 25h. Place log 4 on top of the right end of the left log from LGS57 and on top of log 1, see figure 25i.

Installation



Figure 33i.



Figure 33j.

Step 5: Identify logs in kit LGS59



Figure 33k.

From LGS59, place log 1 on top of log 3 from LGS58 crossing over the end of the pilot cover. DO NOT place the log on the surface of the pilot cover, see figure 25l.



Figure 33l.

From LGS59, place log 4 in front of the ports, in front of the left log from LGS57. See figure 25m. Place log 6 across the burner tray after the end of the ports. DO NOT place the log over the ports.



Figure 33m.



Figure 33n.

Step 6: From LGS59, place log 3 in front of the ports near the middle of the burner, in front of the right log from LGS57. Place log 3 on top of log 3, see figure 25o.



Figure 33o.

From LGS59, place log 5 in front of the ports near the middle of the burner, in front of the left log from LGS57. Place log 6 from LGS58 on top of log 5, keeping it in front of the ports, see figure 25q.



Figure 33p.



Figure 33q.

Optional: You can place a second LGS59 kit in any configuration pleasing to you over the light tray. Make sure to install the inner glass before you do this.



Operation

FOR YOUR SAFETY - READ BEFORE LIGHTING :



WARNING If the information in these instructions are not followed exactly, a fire or explosion may result causing property damage, personal injury or death.

WARNING / CAUTION: Hot while in operation. Do not touch. Severe burns may result. Keep children, clothing, furniture, gasoline and other liquids having flammable vapors away.

See installation and operating instructions accompanying this appliance.

- A. This appliance has a pilot which is lit automatically. Do not attempt to light the pilot by hand.
- B. BEFORE LIGHTING smell all around the appliance area for gas. Be sure to smell next to the floor because some gas is heavier than air and will settle on the floor.
 - What To Do if You Smell Gas:
 - Do not try to light the appliance.
 - Do not touch any electrical switch. Do not use any phone in your building.
 - Immediately call your gas supplier from a neighbour's phone. Follow the gas suppliers instructions.
- C. If you cannot reach your gas supplier, call the Fire Department.
- D. Use only your hand to push in or turn the gas control knob. Never use tools. If the knob will not push in or turn by hand, don't try to repair it. Call a qualified service technician. Force or attempt to repair may result in a fire or explosion.
- E. Do not use this appliance if any part has been under water. Immediately call a qualified service technician to inspect the appliance and to replace any part of the control system, and any gas control which has been under water.

LIGHTING INSTRUCTIONS:

1. STOP! Read the safety information above on this label.
2. Turn the fireplace "OFF" using the wall switch or remote control.
3. Wait 5 minutes to clear out any gas. If you smell gas, STOP! Follow "B" in the safety information above on this label. If you don't smell gas, go to the next step.
4. Turn the fireplace "ON" using the wall switch or remote control.
5. The wall switch LED and heat sensor/combustion air LED will light up.
6. Once the predetermined airflow is established in the firebox, the flue gas switch LED will light up after 30 seconds.
7. After approximately 1 minute the hot surface igniter will start to glow. The pilot will light up, followed by the main burner. The fireplace will then start up.

NOTE: This unit is equipped with an ignition system that lights the pilot burner automatically. Do not attempt to light the pilot by hand.

This unit is equipped with advanced safety controls including pre and post purge timers. The fireplace will not turn on until all of the safety conditions are met. The fans in the fireplace may operate for an extended period of time even after the wall switch is turned off.

NOTE: If the igniter does not glow, even after 3 minutes have passed, follow the instructions "To Turn Off Gas To Appliance" and call your service technician or Montigo dealer.



Control box LED lights

TO TURN OFF GAS TO APPLIANCE:

1. Turn the fireplace off using the wall switch or remote control.
2. Turn off all electrical power to the appliance.
3. Locate the gas shut off valve for the appliance and turn off.

PIN LB1174-112614

Figure 26. Lighting Instructions

Maintenance



Maintenance



WARNING

This fireplace has multiple power sources. Disconnect all power before servicing.

General

- **Have the fireplace and installation inspected yearly.** The inspection must include, but is not limited to, the following:
 - A visual check of the entire vent system and termination.
 - An inspection of the door gaskets to ensure a proper seal.
 - An inspection of the burner, vent run, and primary air openings.
 - An inspection of the gas valve, gas components, and pilot flame.

NOTICE

Do not use ammonia based or abrasive cleaners on the glass, they will permanently etch the surface. Use an approved gas fireplace glass cleaner such as Kel-Kem or White off.

Cleaning

When the fireplace is first activated, there may be some smoking and a visible film may be left on the glass. This is a normal condition, and is the result of burning of protective coatings on new metal.

- Glass must be cleaned periodically to remove any film (which is a normal by-product of combustion) which may be visible. Film can easily be removed by removing the door, as shown in section. Handle the door carefully, and clean it with non-abrasive, non-ammonia based glass cleaners. One of the most effective products is Kel-Kem.
- Use a vacuum cleaner or whisk broom to keep the control compartment, burner, and firebox free from dust and lint.

Procedure for Checking The Flue Gas Switch and Thermal Switch

- 1). Remove the safety screen and outer glass, see appropriate sections.
- 2). Disconnect the power vent harness from the plug in the control box.
- 3). Turn wall switch to 'ON' position.
- 4). Monitor the flue gas LED indicator for 2 minutes and ensure that neither the LED indicator nor the ignitor illuminate. If LED indicator or ignitor illuminates the flue gas switch is not functioning properly. Disconnect the power to the unit, contact your technical support representative.
- 5). Using a heat gun, warm up the heat sensor located between two glass panels until heat sensor LED turns off.
- 6). Confirm LED resets within 10 minutes.
- 7). Reconnect power vent wire harness and reinstall the outer glass panel and safety screen.



Figure 34. Thermal Switch Location



Maintenance

Replacing Light Bulbs

The **RP620*** light bulbs can be replaced in a few simple steps. Begin by disconnecting the power to the fireplace. Follow the directions for removing the screen and outer glass on **page 30**. Once the screen and outer glass have been successfully removed, proceed with **figures 28 - 28b**.

Note: Always wear gloves when handling the fireplace light bulbs or glass panels.

Step 1: Remove any decorative media and up-lighting glass from the light kit tray.



Figure 35.

Step 2: To remove a light bulb, pull the light bulb away from the light bulb connector and lift the light bulb up and out.



Figure 35a.

Step 3: Rotate the newly replaced light bulb in a full circle.



Figure 35b.

Step 4: Replace up-lighting glass in the burner tray.

Maintenance



Servicing the Burner

Follow the steps below to remove the burner to service the unit.

Step 1:

Remove the safety screen and outer and inner glass.

Step 2: Remove firestones



Figure 36. Remove 4 rail screws found at the end of the rails.

Step 3:



Figure 36a.

Step 4: Lift one end of the rail up above the firebox ceiling baffle. Pull the other end out the front of the fireplace.



Figure 36b.



Figure 36c. . Remove 4 screws and then remove gas connection cover.

Step 5:



Figure 36d. Disconnect the flexible gas connection line.

Step 6:



Figure 36e. After removing the appropriate fasteners, remove the burner assembly.

Step 7:



Figure 36f. Remove the valve cover to gain access to the valves.



Figure 36g. Gas Valve and Pressure Sensor



Maintenance

Replacement Parts

Honeywell HSI	
	RP620
NG Gas Valve	RGC1004
LP Gas Valve	RGC3045
NG Pilot Assembly	RPA003
LP Pilot Assembly	RPA004
Inner Glass	RGL4000
Outer Glass	RDTRP620
Power Vent Control Box	RESCB2
Replacement Screen	RSCR620
Fuse, AGC-5Amp	EC1122
Tungsten Halogen Lamp	REC1319
Inner Door Clips	RIGC-RP620
Porcelain Panel Set	RPPRP620 (all 3 panels)
NG Driftwood Log Set	LGRP6N
LP Driftwood Log Set	LGRP6L

Appendix

Appendix A: Warranty

The Warranty

The Companies warrants the Montigo Gas Appliance to be free from defects in materials and workmanship at the time of manufacture. On the Montigo fireplace, there is a ten-year warranty on the firebox and its components, a five-year warranty on the main burner and pilot burner, and a one-year warranty on the gas control valve, fibre logs and Power Vent Module. The Glass, plated / painted finishes, and refractory lining are exempt from the warranty.

Remedy And Exclusions

The coverage of this Warranty is limited to all components of the Gas Appliance manufactured by The Companies.

This Warranty only covers Montigo Gas Appliances installed in the United States or Canada.

If the components of the Gas Appliance covered by this Warranty are found to be defective within the time frame stated (see The Companies right of investigation outlined below). The Companies will, at its option, replace or repair defective components of the Gas Appliance manufactured by The Companies at no charge, and will also pay for reasonable labour costs incurred in replacing or repairing components. If repair or replacement is not commercially practical, The Companies will, at its option, refund the purchase price of the Montigo Gas Appliance.

This Warranty covers only parts and labour as provided above. In no case shall The Companies be responsible for materials, components, or construction which are not manufactured or supplied by The Companies, or for the labour necessary to install, repair or remove such materials, components or construction. All replacement or repair components will be shipped F.O.B. the nearest The Companies factory.

Qualifications To The Warranty

The Gas Appliance Warranty outlined above is further subject to the following qualifications:

- (1) The Gas Appliance must be installed in accordance with The Companies installation instructions and local building codes. The Warranty on this Montigo Gas Appliance covers only the component parts manufactured by The Companies. The use of components manufactured by others with this Montigo Gas Appliance could create serious safety hazards, may result in the denial of certification by recognized national safety agencies, and could be in violation of local building codes. This warranty does not cover any damages occurring from the use of any components not manufactured or supplied by The Companies
- (2) The Montigo Gas Appliance must be subjected to normal use. The Gas Appliances are designed to burn gas only. Burning conventional fireplace fuels such as wood, coal or any other solid fuel will cause damage to the Gas Appliance, will produce excessive temperatures and will result in a fire hazard.

Limitations On Liability

It is expressly agreed and understood that The Companies sole obligation, and purchaser's exclusive remedy under this Warranty, under any other warranty, expressed or implied, or in contract, tort or otherwise, shall be limited to replacement, repair, or refund, as specified above.

In no event shall The Companies be responsible for any incidental or consequential damages caused by defects in its products, whether such damage occurs or is discovered before or after replacement or repair, and whether or not such damage is caused by The Companies negligence. Some states do not allow the exclusion or limitation of incidental or consequential damages, so the above limitation or exclusion may not apply to you. The duration of any implied warranty with respect to this Montigo Gas Appliance is limited to the duration of the foregoing warranty. Some states do not allow limitation on how long an implied warranty lasts, so the above may not apply to you.

Investigation Of Claims Against Warranty

The Companies reserves the right to investigate any and all claims against this Warranty and to decide upon method of settlement.

The Companies Are Not Responsible For Work Done Without Written Consent

The Companies shall in no event be responsible for any warranty work done without first obtaining The Companies written consent.

Dealers Have No Authority To Alter This Warranty

The Companies employees and dealers have no authority to make any warranties nor to authorize any remedies in addition to or inconsistent with those stated above.

How To Register A Claim Against Warranty

In order for any claim under this Warranty to be valid, The Companies must be notified of the claimed defect in writing or by telephone, as soon as reasonably possible after the defect is discovered. Claims against this Warranty in writing should include the date of installation, and a description of the defect.

Other Rights

This Warranty gives you specific legal rights, and you may also have other rights which vary from state to state.

NOTE: *The Companies as stated above refer to - Canadian Heating Products Inc. and/or Montigo Del Ray Corp.*

Canadian Heating Products Inc. and/or Montigo DelRay Corp. reserves the right to make changes at any time, without notice, in design, materials, specifications, prices and also to discontinue colors, styles and products.

Appendix

Appendix B: State of Massachusetts

Amendment

(Gas Fireplace / Equipment sold in the State of Massachusetts)

5.08: Modifications to NFPA-54, Chapter 10

(1) Revise NFPA-54 section 10.5.4.2 by adding a second exception as follows:

Existing chimneys shall be permitted to have their use continued when a gas conversion burner is installed, and shall be equipped with a manually reset device that will automatically shut off the gas to the burner in the event of a sustained back-draft.

(2) Revise 10.8.3 by adding the following additional requirements:

(a) For all side wall horizontally vented gas fueled equipment installed in every dwelling, building or structure used in whole or in part for residential purposes, including those owned or operated by the Commonwealth and where the side wall exhaust vent termination is less than seven (7) feet above finished grade in the area of the venting, including but not limited to decks and porches, the following requirements shall be satisfied:

1. INSTALLATION OF CARBON MONOXIDE DETECTORS. At the time of installation of the side wall horizontal vented gas fueled equipment, the installing plumber or gas fitter shall observe that a hard wired carbon monoxide detector with an alarm and battery back-up is installed on the floor level where the gas equipment is to be installed. In addition, the installing plumber or gas fitter shall observe that a battery operated or hard wired carbon monoxide detector with an alarm is installed on each additional level of the dwelling, building or structure served by the side wall horizontal vented gas fueled equipment. It shall be the responsibility of the property owner to secure the services of qualified licensed professionals for the installation of hard wired carbon monoxide detectors

a. In the event that the side wall horizontally vented gas fueled equipment is installed in a crawl space or an attic, the hard wired carbon monoxide detector with alarm and battery back-up may be installed on the next adjacent floor level.

b. In the event that the requirements of this subdivision can not be met at the time of completion of installation, the owner shall have a period of thirty (30) days to comply with the above requirements; provided, however, that during said thirty (30) day period, a battery operated carbon monoxide detector with an alarm shall be installed.

2. APPROVED CARBON MONOXIDE DETECTORS. Each carbon monoxide detector as required in accordance with the above provisions shall comply with NFPA 720 and be ANSI/UL 2034 listed and IAS certified.

3. SIGNAGE. A metal or plastic identification plate shall be permanently mounted to the exterior of the building at a minimum height of eight (8) feet above grade directly in line with the exhaust vent terminal for the horizontally vented gas fueled heating appliance or equipment. The sign shall read, in print size no less than one-half (1/2) inch in size, "GAS VENT DIRECTLY BELOW. KEEP CLEAR OF ALL OBSTRUCTIONS".

4. INSPECTION. The state or local gas inspector of the side wall horizontally vented gas fueled equipment shall not approve the installation unless, upon inspection, the inspector observes carbon monoxide detectors and signage installed in accordance with the provisions of 248 CMR 5.08(2)(a)1 through 4.

(b) EXEMPTIONS: The following equipment is exempt from 248 CMR 5.08(2)(a)1 through 4:

1. The equipment listed in Chapter 10 entitled "Equipment Not Required To Be Vented" in the most current edition of NFPA 54 as adopted by the Board; and

2. Product Approved side wall horizontally vented gas fueled equipment installed in a room or structure separate from the dwelling, building or structure used in whole or in part for residential purposes.

(c) MANUFACTURER REQUIREMENTS - GAS EQUIPMENT VENTING SYSTEM PROVIDED. When the manufacturer of Product Approved side wall horizontally vented gas equipment provides a venting system design or venting system components with the equipment, the instructions provided by the manufacturer for installation of the equipment and the venting system shall include:

1. Detailed instructions for the installation of the venting system design or the venting system components; and
2. A complete parts list for the venting system design or venting system.

(d) MANUFACTURER REQUIREMENTS - GAS EQUIPMENT VENTING SYSTEM NOT PROVIDED. When the manufacturer of a Product Approved side wall horizontally vented gas fueled equipment does not provide the parts for venting the flue gases, but identifies "special venting systems", the following requirements shall be satisfied by the manufacturer:

1. The referenced "special venting system" instructions shall be included with the appliance or equipment installation instructions; and

2. The "special venting systems" shall be Product Approved by the Board, and the instructions for that system shall include a parts list and detailed installation instructions.

(e) A copy of all installation instructions for all Product Approved side wall horizontally vented gas fueled equipment, all venting instructions, all parts lists for venting instructions, and/or all venting design instructions shall remain with the appliance or equipment at the completion of the installation.

(3) After NFPA-54 section 10.10.4.2 add a new section 10.10.4.3 as follows:

When more than four gas appliances are to be vented through a common gas vent or common horizontal vent manifold, a plan of the proposed vent installation shall be submitted to the Inspector and the serving gas supplier for review and approval.



RP620

Single Sided Gas Fireplace

