

Universal Stands Instructions

⚠ WARNING



Read these instructions and the warnings and instructions for all equipment being used before operating this tool to reduce the risk of serious personal injury.

- **Secure machine to the stand.** This will reduce the risk of tipping and serious injury.

If you have any question concerning this RIDGID® product:

- Contact your local RIDGID distributor.
- Visit RIDGID.com to find your local RIDGID contact point.
- Contact Ridge Tool Technical Service Department at rttech-services@emerson.com, or in the U.S. and Canada call (800) 519-3456.

Description

RIDGID® 100A, 150A and 200A Universal Stands are used to mount and support the 300 Compact, 535, 535A, 1224 and 1233 Threading Machines.

See the product label for specifications or consult the RIDGID catalog.



Figure 1 – RIDGID 100A and 150A Stands

Assembly

1. Determine what threading machine the stand will be used with and the required stand width:
 - 535 (pre 2001), 300 Compact and 1233 - Narrow Stand Width of 12" (30.5 cm) (535 machines made prior to 1996 require adapter bracket Cat. No. 58007)
 - 535 (2001 and newer), 535A and 1224 - Wide Stand Width of 15.5" (39.4 cm).
2. Assemble the stand, leaving the fasteners hand tight. Make sure the "Inside" decals are towards the inside of the stand (see Figure 2). For the Wide Stand width, use the spacers and 4" long bolts. For the 150A and 200A, make sure that the axles are in the forked ends of the stand stop (see Figure 3).
3. With the stand on a smooth, level surface, securely tighten all fasteners.
4. Carefully place the threading machine on the stand. For 150A and 200A, place the threading machines with carriage toward the handles (see Figure 4). Align the mounting holes in the threading machine base with the appropriate holes in the stand, as shown in Figure 2, for proper balance. Securely attach machine to stand.

Inspection/Maintenance

Clean the stand to aid inspection and improve control. Inspect the stand before each use for proper assembly, wear, damage, modification or other issues that could affect safe use. If any problems are found, do not use until corrected.

Lubricate all moving parts/joints as needed with light lubricating oil. Wipe up excess oil.

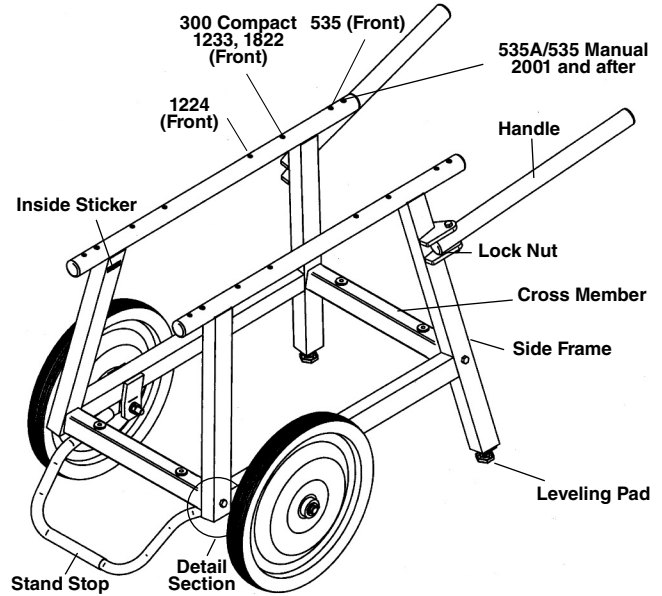

Figure 2 – Stand Parts (200A Stand shown)

Narrow Configuration

(300 Compact, 1233, 1822-I, 535 (Pre 2001))

Wide Configuration

(1224, 535A/535 Manual (2001 and after))

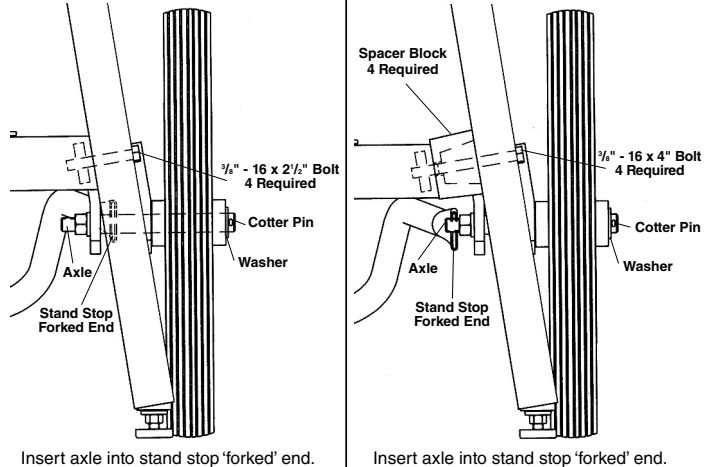

Insert axle into stand stop 'forked' end.

Insert axle into stand stop 'forked' end.

Figure 3 – Stand Width (Detail Section from Figure 2)

Set Up and Operation

1. Always use the stand in clear, level, stable locations.
2. Stand leveling – Loosen nut and turn leveling pad to adjust. Do not allow pad to come out of the leg. Tighten nut to lock pad in place.

Transporting

1. Before moving, make sure all equipment and material is removed from the machine and stand or properly secured to prevent falling or tipping. Make sure the switch is in the OFF position and the cord unplugged. The cabinet on the 200A includes slots for routing the foot switch and power cord into the cabinet for storage.
2. The 150A and 200A wheeled stands allow threading machines to be moved over smooth, level surfaces. To use, fully open handles and lift legs slightly off the ground before rolling.
3. A forklift can be used to move the threading machine/stands. Place the forks under the stand upper rails (just below the threading machine) (Figure 4).