

Features and Benefits

1. The complete tapping sleeve is made in stainless steel 304/316 (unless the carbon steel flange option is ordered) and shall be passivated so as to return the welded stainless steel to its original corrosion resistant state.
2. Built in range allows reduction of inventory.
3. Stainless steel and Carbon Steel flanges available.
4. Stainless steel washerbar included to allow a heavy bearing surface for nuts.

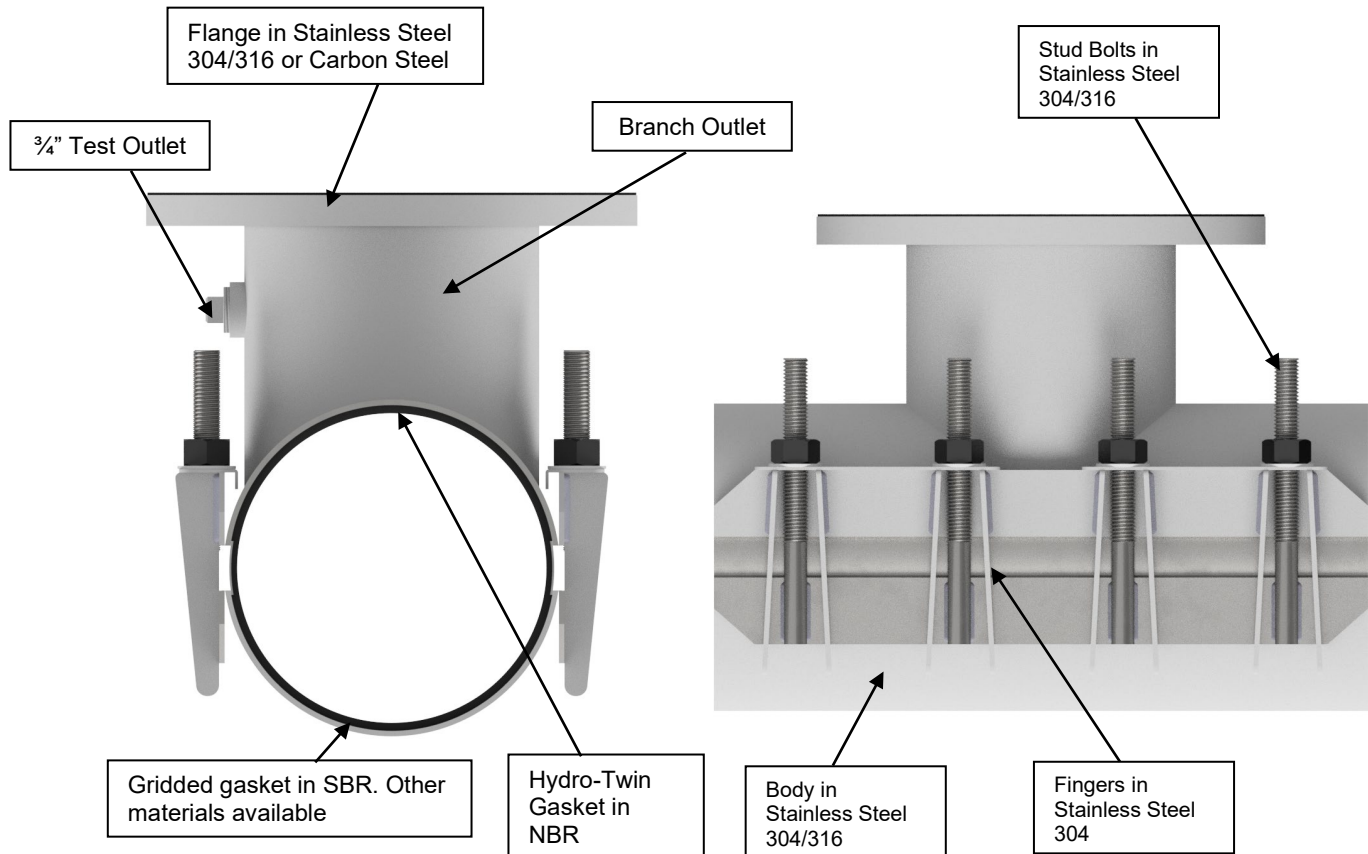

Scope

The intent of this specification is to receive an all stainless Tapping Sleeve. The Tapping Sleeve furnished shall be equivalent to Model 3480AS or 3480CS Tapping Sleeve as manufactured by PowerSeal Pipeline Products Corporation.

Design and Material Specification

The Tapping Sleeve shall be rated for a maximum working pressure of 250 psi and 312 psi testing pressure for outlet sizes 4” to 8”. For outlet sizes 10” and 12” a maximum working pressure 200 psi and 300 psi testing pressure. For pipe sizes larger than 30” a maximum working pressure up to 100 psi and 150 psi testing pressure.

- The tapping sleeve shall meet or exceed all material specifications as listed below.
 1. The sleeve meets all AWWA C223 requirements.
 2. The tapping sleeve shall have face gasket SBR, branch sealing hydro twin, and complete circle gasket all permanently attached to the sleeve at the factory. The branch sealing gasket shall be our patented Hydro-Twin design in NBR (-25F° - +248F°), and the complete circle gasket shall be our patented check-o-seal design in SBR (-25F° - +200F°).
 3. Branch to flange and branch to shell connections are double welded. Outer structural weld GMAW (FCAW) and inner fusion weld GTAW (TIG).
 4. Finger lug assemblies shall be structurally welded GMAW (FCAW) to the shell and the test outlet shall be fusion welded GTAW (TIG) to the branch inside and out.
 5. The Armor plates shall be bonded to the gasket.
 6. There shall be no paper or plastic adhesive labels attached to the tapping sleeve, any information appearing on the sleeve shall be stenciled.

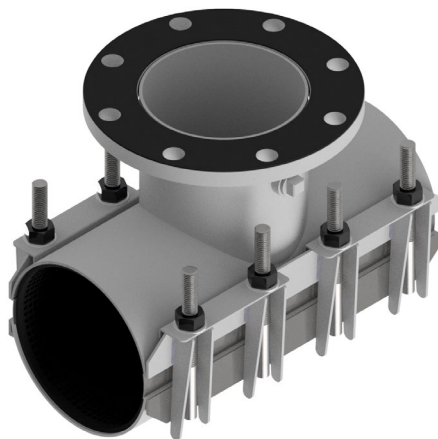

Material Specifications		
Part Name	Material	Mat. specs
Flange	SST 304/316 or Carbon Steel	AWWA C115
Face Gasket	SBR	AWWA C115AP
Branch	Stainless Steel type 304/316	ASTM A240
Test Plug	Stainless Steel type 304/316	ANSI B2.1
Shell	Stainless Steel type 304/316	ASTM A240
Finger Assembly	Stainless Steel type 304/316	ASTM A240
Hydrotwin	NBR	ASTM D2000
Gasket	SBR	ASTM D2000
Stud Bolt	Stainless Steel type 304/316	ASTM A193
Nuts	Stainless Steel type 304/316	ASTM A194
Washer Bar	Stainless Steel type 304/316	ASTM A240
Friction Washer	Delrin	MIL-A50424