

MUELLER®

E-5™ and D-5™ Drilling Machines

TABLE OF CONTENTS	PAGE
E-5 General Information	2
D-5 General Information	3
Operating Instructions	4-5
E-5 Parts	6
D-5 Parts	7

⚠ WARNING:

1. Read and follow instructions carefully. Proper training and periodic review regarding the use of this equipment is essential to prevent possible serious injury and/or property damage. The instructions contained herein were developed for using this equipment on fittings of Mueller manufacturer only, and may not be applicable for any other use.
2. DO NOT exceed the pressure ratings of any components or equipment. Exceeding the rated pressure may result in serious injury and/or property damage.
3. Safety goggles and other appropriate protective gear should be used. Failure to do so could result in serious injury.
4. Pressure test, check for and repair leaks in all fittings and components each time one is installed or any joint or connection is broken. Failure to find and repair a leak from any source in the fittings, by-pass lines or equipment could result in an explosion and subsequent serious injury and/or property damage.
5. Mueller® Drilling Machines and Equipment have been carefully designed and engineered to work together as a unit. The use of equipment manufactured by someone other than Mueller Co. may cause excessive wear or a malfunction of the Mueller machines.

Mueller Co.

Reliable Connections™

Customer Service Center

Decatur, Illinois

800.423.1323 • 800.798.3131

www.muellercompany.com • www.muellergas.com

moreinfo@muellercompany.com

All warranties, expressed or implied, for Mueller Drilling Machines are rendered null and void if the machines are used with shell cutters or equipment manufactured by someone other than Mueller Co.

MUELLER® E-5™ Drilling Machine

General Information

Capacity and Use

The E-5 Drilling Machine is hand or power operated for drilling holes 1/2" – 2" inclusive, in any size or kind of pipe. (Under certain conditions the maximum size may be increased to 3 3/4".)

Maximum Working Pressure

500psi at 100° F.

375psi at 250° F.

The working pressure or temperature rating is reduced accordingly if any attachment, valve or fitting, subjected to pressure when using the machine, has a maximum working pressure or temperature rating less than that specified above.

Length of Travel – 12 1/8"

Equipment Furnished with Each Machine

- Ratchet Handle
- Body Gasket
- Adjustable Wrench
- 2 End Wrenches
- Cutting Grease

The machine adapter nipple, drill holder and drill shown at left are not included in the equipment furnished with this machine. These items must be ordered according to the size and type of valve and pipe to be tapped.

3/4" & 1" tools and equipment for this machine are the same as above for the E-4 Drilling Machine in the latest Mueller water and gas catalogs.

For operating instructions see pages 4 – 5 and for E-5 Drilling Machine Parts see page 6.

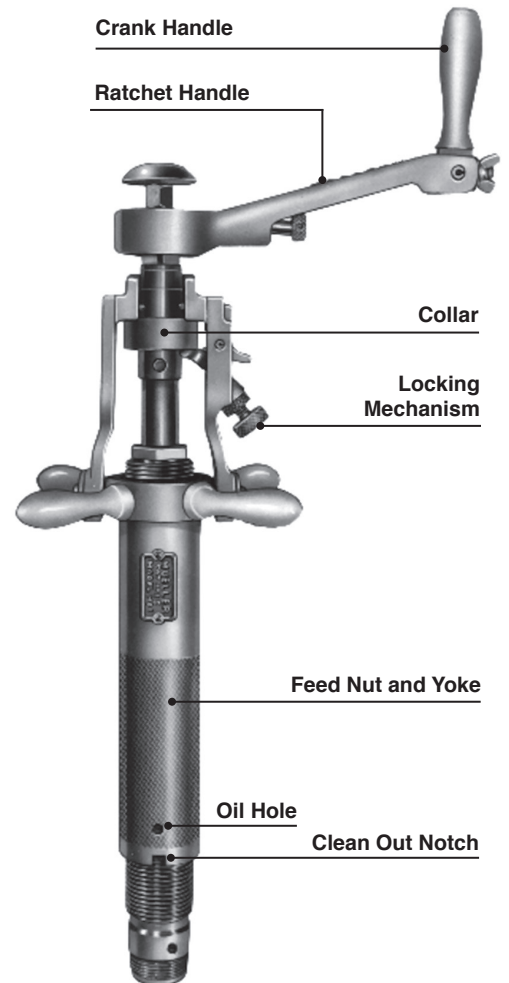

Shipping Specifications

DESCRIPTION	E-5
Machine and Equipment Furnished in Metal Case	59 1/2 lbs (27 kg)
Machine ONLY	25 lbs (11 kg)
Shipping Length	22"
Extended Length	32"

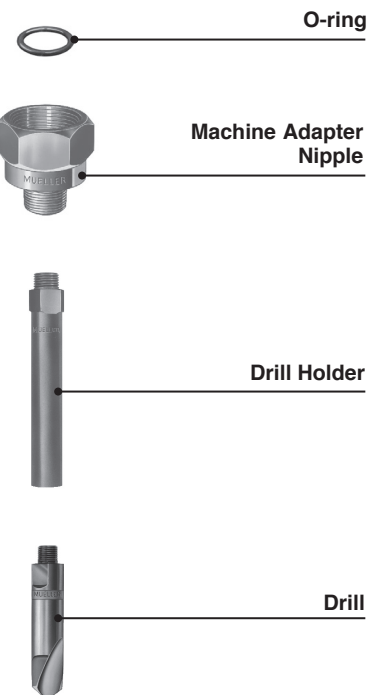

Small Drilling Machine Selection Guide

Machine	Drill or Cutter Capacity	Maximum Pressure	Operation	Type of Pipe	Recommended Use
E-5 Drilling Machine	7/16" – 1 7/8"	500psig (3450 kPa)	Hand or Power	Cast Iron, Cement-lined Cast Iron, Ductile Iron, Cement-lined Ductile Iron, A-C, Concrete, Steel & PVC	Making main to service connections in pressurized main

MUELLER® D-5™ Drilling Machine

General Information

Capacity and Use

The D-5 Drilling Machine is hand or power operated for drilling holes 1/2" – 2" inclusive, in any size or kind of pipe. (Under certain conditions the maximum size may be increased to 3 3/4".)

Maximum Working Pressure

500psi at 100° F.

375psi at 250° F.

The working pressure or temperature rating is reduced accordingly if any attachment, valve or fitting, subjected to pressure when using the machine, has a maximum working pressure or temperature rating less than that specified above.

Length of Travel – 14"

Equipment Furnished with Each Machine

- Ratchet Handle
- Body Gasket
- Adjustable Wrench
- End Wrench
- Cutting Grease

The machine adapter nipple, cutter arbor, shell cutter and pilot drill shown at right are not included in the equipment furnished with this machine. These items must be ordered according to the size and type required.

Tools and equipment for this machine are the same as those listed for the D-4 Drilling Machine in the latest Mueller water and gas catalogs.

For operating instructions see pages 4 – 5 and for D-5 Drilling Machine Parts see page 7.

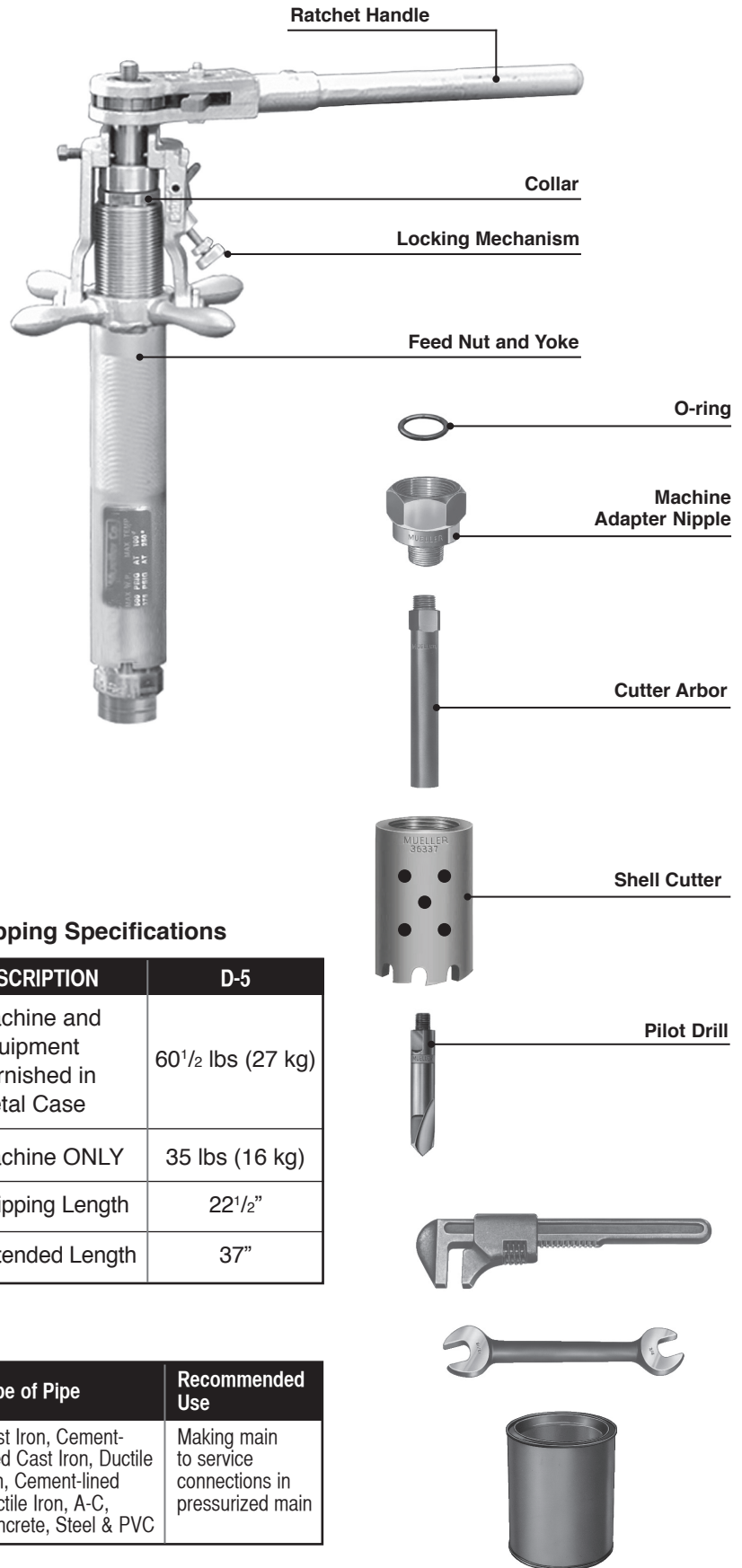

Shipping Specifications

DESCRIPTION	D-5
Machine and Equipment Furnished in Metal Case	60 1/2 lbs (27 kg)
Machine ONLY	35 lbs (16 kg)
Shipping Length	22 1/2"
Extended Length	37"

Small Drilling Machine Selection Guide

Machine	Drill or Cutter Capacity	Maximum Pressure	Operation	Type of Pipe	Recommended Use
D-5 Drilling Machine	5/8" – 2"	500psig (3450 kPa)	Hand or Power	Cast Iron, Cement-lined Cast Iron, Ductile Iron, Cement-lined Ductile Iron, A-C, Concrete, Steel & PVC	Making main to service connections in pressurized main

MUELLER® D-5™ and E-5™ Drilling Machines

Operating Instructions

1. Oil all working parts. Keep all threaded surfaces and boring bar well lubricated and free from dirt and foreign material. The feed tube on the E-5 and D-5 is designed to aid in cleaning the threads when advancing or retracting the feed tube and yoke. If equipped, keep the clean-out notch and oil holes of these machines clean at all times. E-5 and D-5 Machines are equipped with O-ring packing. Under normal conditions the only maintenance required for the O-rings is lubrication. If the O-rings should become excessively worn they should be replaced.

2. Advance boring bar until drilling tools may be attached.

3. Attach drilling tools to boring bar. If drilling tools to be used will not pass completely through the machine adapter nipple to be used, attach the machine adapter nipple before attaching the drilling tools (see instruction 5).

Flat drills are used for drilling through straightway or flatway stops. Measure dimensions "A" and "C" on the flat drill to be sure that they are less than minimum dimensions "a" and "c" through the body and key of the stop to be used.

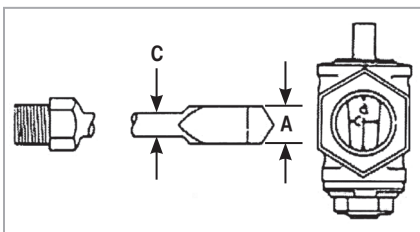

When advancing or retracting the boring bar equipped with a flat drill, make sure that the drill is in the proper position to pass through the port opening in the key and body of the stop being used. (Before advancing the boring bar the correct position can be marked on collar of boring bar.)

4. Coat drill, or shell cutter, and pilot drill thoroughly with Mueller cutting grease. (DO NOT use cutting grease when drilling A-C or concrete pipe.)

5. Attach proper size machine adapter nipple to the body of the machine making sure that the body gasket or washer is in place and in good condition.

6. Retract boring bar to its rearmost position.

7. Attach drilling machine and machine adapter nipple to the valve, stop or fitting that is to be drilled through.

8. Open valve, stop or fitting being used.

9. Advance boring bar until drill or pilot drill contacts the pipe to be drilled.

10. Adjust feed tube and yoke (or feed nut and yoke) so that the yoke is engaged with the top of the friction collar on boring bar. Raise pivot arm of locking mechanism on side of yoke so that it is positioned under friction collar and lock in place with operating screw.

11. Retract boring bar a slight amount.

12. Measure and mark the travel required to complete the drilling operation. (Mark the point on the body that the feed tube will reach when drilling is completed.)

13. DRILL THE MAIN Power Operated Method Using Mueller H-603 Electric Power Operator, H-604 Air Power Operator, or H-705 Hydraulic Power Operator

The E-5 and D-5 Drilling Machines have been designed to permit the addition of a power operator. The power operator will drive the tools and provide automatic feed during the drilling operation. The power operator consists of a gear case and motor using an electric, air, or hydraulic motor for the power source.

IMPORTANT: When using H-604 Air Motor Power Operator. Install an in-line lubricator as close to the unit as practical and adjust for slight oil mist from exhaust – maintain pressure of 90psig. We recommend the use of a gauge at the throttle to determine the actual pressure of air at the air motor.

The gear case attaches to the machine by the means of two sockets. The inner or small socket drives the boring bar. The outer or large socket drives the feed yoke through a gear reduction as the boring bar is rotated. The resulting feed on the drill is 0.10" per revolution of the boring bar.

The operator takes the torque of the motor resulting from the drilling operation, so the motors are equipped with a squeeze type trigger throttle. If for some reason a drill should stick, the motor can be shut off quickly.

- Place the gear case and motor on the drilling machine aligning the sockets with the square shanks on the boring bar and feed yoke. Socket which contacts feed yoke should be closed and wing nut secured.
- Set position of air or electric motor switch to give **clockwise** rotation of boring bar.

NOTE: Feed the yoke by hand when using 1½" and 2" drill bits.

Hand Operation

Drill the hole by operating the ratchet handle **clockwise** and turning the feed tube and yoke (or feed nut and yoke) **clockwise** a little at a time. Use a light, even feed and finish with a light, even feed. The special locking mechanism that locks the boring bar to the feed yoke prevents the drill from spiraling into the hole before the hole is completely drilled. To prevent over-feeding when drilling small holes and also when starting to drill larger holes, apply the feed by gripping the knurled section of the feed tube instead of feed handles.

MUELLER® D-5™ and E-5™ Drilling Machines

Operating Instructions

This will apply a light, even feed. Feed handles should be used to apply a heavier feed.

NOTE: When nearing the completion of the cut DO NOT over-feed or the cutting tools may be forced through before all the material is drilled or cut out.

The E-5 Machine is now furnished with a combination ratchet and crank handle. When drilling small holes the crank handle should be turned upward and rotated in continuous circles instead of ratcheting.

14. Continue drilling operation until pipe is drilled through completely. This can be determined by the feel of the feeding mechanism, the pull on the ratchet handle or by measuring the advance of the boring bar. If drilling is not completed, retract boring bar slightly and ratchet and feed slowly to remove the remaining metal a little at a time.

15. When drilling operation is completed turn operating screw on locking mechanism **counter-clockwise** to unlock pivot arm. Remove feed-yoke from friction collar and retract boring bar to its rearmost position. Be sure that the drill or pilot drill clears the valve gate or key of stop if a stop is being used.

NOTE: If the pressure in the main is 90psi or over, the locking mechanism on the feed yoke may be used to control the upward movement of the boring bar by leaving it attached until uppermost position is reached, then disconnect as described above.

 **CAUTION: DO NOT** reverse rotation of ratchet handle when retracting the boring bar.

The pressure inside of the drilling machine will tend to raise the boring bar. Hold down on the boring bar or use the feed yoke to control the upward motion of the boring bar thereby preventing shock or damage to the drilling machine.

16. Close valve, stop or fitting being used.

17. Remove drilling machine and machine adapter nipple as a unit.

18. Advance boring bar and remove machine adapter nipple and drilling tools from machine.

19. After being used, clean dirt and foreign material from machine and equipment. Lubricate machine and give drilling tools a light coat of oil to protect them from rust. When not in use, the machine and equipment furnished with each machine should be stored in the box furnished with the machine. The machines should be dis-assembled periodically, and the boring bar and the machine body thoroughly cleaned both inside and out. By doing this, any dirt, grit, chips, or other foreign material that might have possibly accumulated on the boring bar or in the body of the machine may be detected and removed before any damage is done. An accumulation of foreign material on either the boring bar or inside of the body will restrict the reverse travel of the boring bar.

SPECIAL NOTE: In general, the machines should be lubricated as described in instruction No.1. However, due to extreme conditions in some areas (dust, sand, etc.) it may be advisable not to lubricate the feed sleeve or threaded parts of these machines since it would tend to increase the abrasive or wearing action. This procedure, of course, must be at the discretion of the operator.

MUELLER® D-5™ and E-5™ Drilling Machines

E-5 Parts

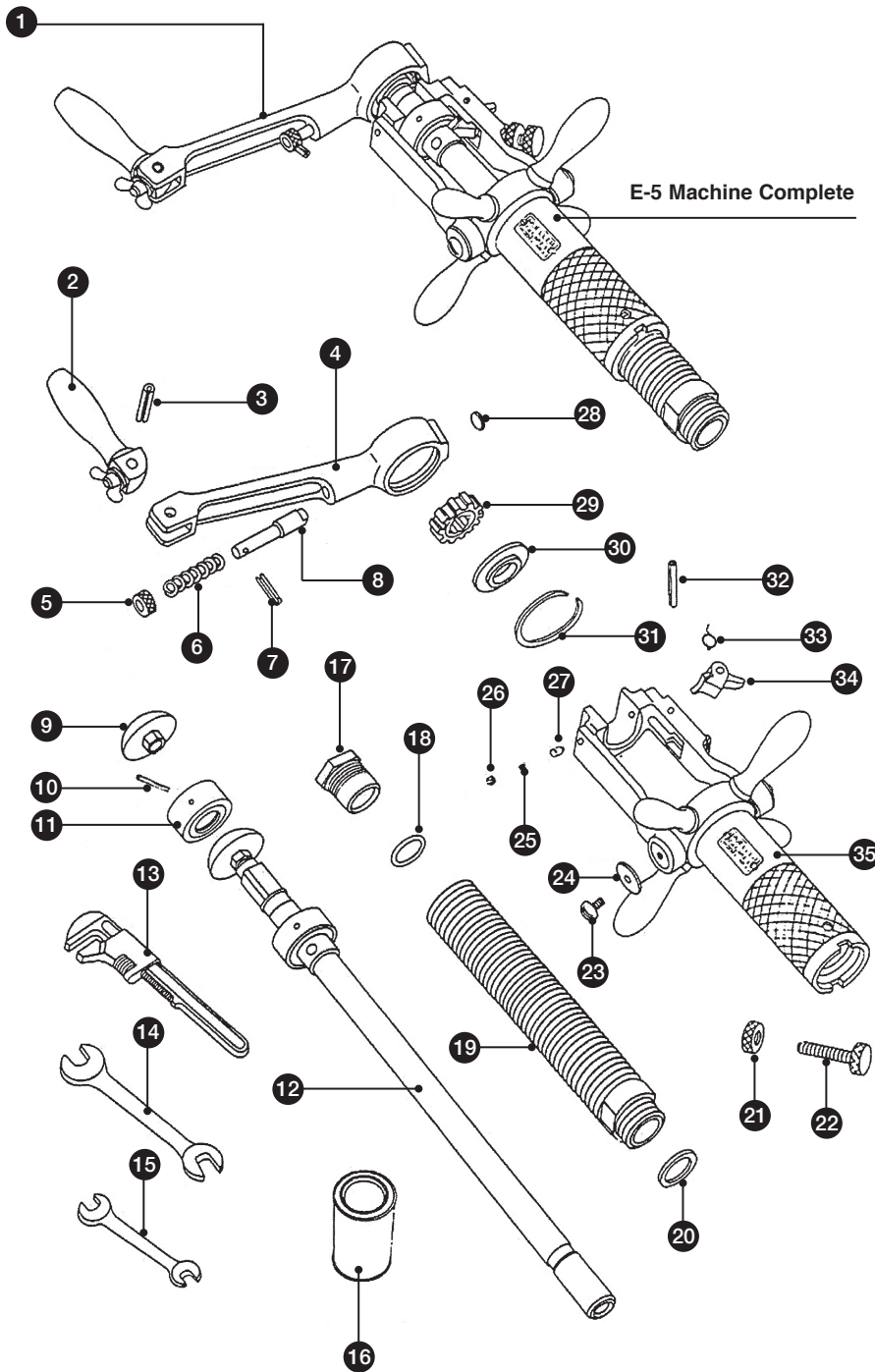

PARTS LIST

ID	PART NAME	PART No.
1	Ratchet Handle Complete	580897
2	Crank Handle	50085
3	Handle Pin	500635
4	Handle	51484
5	Detent Knob	37863
6	Spring	37883
7	Operating Pin	500803
8	Ratchet Dog	51426
9	Knob	83431
10	Friction Collar Pin	48130
11	Friction Collar	580610
12	Boring Bar	580999
13	Adjustable Wrench	91664
14	End Wrench	96536
15	End Wrench	59767
16	Cutting Grease	88366
17	Packing Gland	51432
18	O-Ring Packing	46726
19	Body	503159
20	Body Gasket	47756
21	Lock Nut	502029
22	Operating Screw	502028
23	Retaining Screw (2)	79745
24	Washer (2)	50133
25	Detent Spring (2)	59810
26	Detent Screw (2)	305006
27	Detent Pin (2)	500651
28	Plug	51427
29	Ratchet Wheel	503162
30	Wheel Bushing	503163
31	Retaining Ring	51428
32	Pivot Arm Pin	502027
33	Pivot Arm Spring	502026
34	Pivot Arm	502025
35	Feed Tube & Yoke Complete	580895
36	Metal Case (not shown)	580971

MUELLER® D-5™ and E-5™ Drilling Machines

D-5 Parts

PARTS LIST

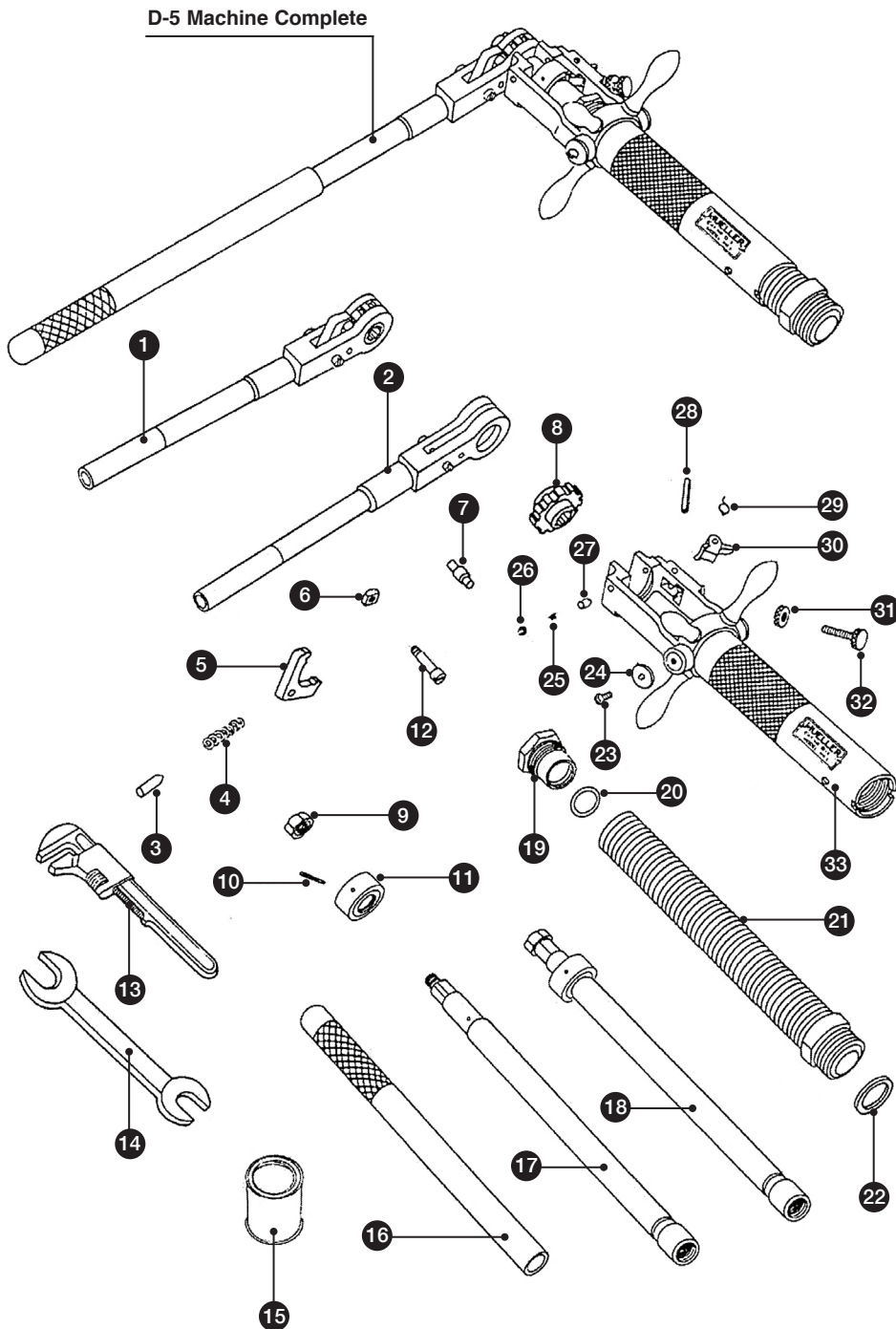

ID	PART NAME	PART No.
1	Ratchet Handle	85308
2	Handle Bar	50111
3	Spring Pin	40006
4	Spring	40007
5	Ratchet Dog	40004
6	Nut	45255
7	Stud	40139
8	Ratchet Wheel	40737
9	Retaining Nut	46029
10	Friction Collar Roll Pin	48130
11	Friction Collar	580610
12	Bolt	40138
13	Adjustable Wrench	91664
14	End Wrench	58196
15	Cutting Grease	88366
16	Handle Extension	86391
17	Boring Bar	503141
18	Boring Bar	580945
19	Packing Gland	51377
20	O-Ring	51458
21	Body	36758
22	Body Gasket	33278
23	Retaining Screw (2)	79745
24	Washer (2)	50133
25	Detent Spring (2)	59810
26	Detent Screw (2)	305006
27	Detent (2)	500651
28	Roll Pin	502027
29	Pivot Arm Spring	502026
30	Pivot Arm	502025
31	Lock Nut	502029
32	Operating Screw	502028
33	Feed Tube & Yoke Complete	580946
34	Metal Case (not shown)	580969



Reliable Connections[®]

Gas (North America)

1.800.798.3131

www.muellergas.com

moreinfo@muellercompany.com

Water (North America)

1.800.423.1323

www.muellercompany.com

moreinfo@muellercompany.com

International

1.423.490.9555

www.mueller-international.com

international@muellercompany.com

Copyright © 2017 Mueller Co., LLC. All Rights Reserved.

The trademarks, logos and service marks displayed in this document herein are the property of Mueller Co., LLC, its affiliates or other third parties.

Products marked with a section symbol (§) are subject to patents or patent applications. For details, visit www.mwppat.com. These products are intended for use in potable water applications. Please contact your Mueller Sales or Customer Service Representative concerning any other application(s).

Form 9335 - 07/17