

D-025 PN 10



Combination Air Valve for Wastewater - Short Version

Description

The D-025 Combination Air Valve combines an air & vacuum component and an air release component in a single body. The valve is specifically designed to operate with liquids carrying solid particles such as wastewater and effluents. The combination air valve discharges air (gases) during the filling or charging of the system, admits air into the system during drainage and at water column separation and releases accumulated air (gases) from the system while it is operating under pressure. The valve's unique design enables the separation of the liquid from the sealing mechanism and assures optimum working conditions.

Applications

- Wastewater & water treatment plants.
- Wastewater and effluent water transmission lines.

Operation

The air & vacuum component discharges air at high flow rates during the filling of the system and admits air into the system at high flow rates during drainage and at water column separation. High velocity air will not blow the float shut. Water will lift the float which activates the sealing of the valve.

At any time during system operation, should internal pressure of the system fall below atmospheric pressure, air will enter the system. The smooth discharge of air reduces pressure surges and other destructive phenomena.

The intake of air in response to negative pressure protects the system from destructive vacuum conditions and prevents damage caused by water column separation. Air entry is essential to efficiently drain the system.

The air release component releases entrapped air in pressurized systems.

Without air valves, pockets of accumulated air may cause the following hydraulic disturbances:

- Restriction of effective flow due to a reduction of the flow area. In extreme cases this will cause complete flow stoppage.
- Obstruction of efficient hydraulic transmission due to air flow disturbances.
- Acceleration of cavitation damages.
- Increase in pressure transients and surges.
- Internal corrosion of pipes, fittings and accessories.
- Dangerous high-energy bursts of compressed air.
- Inaccuracies in flow metering.

As the system fills and is pressurized, the combination wastewater air valve functions in the following stages:

1. Air (gas) is discharged by the valve
2. When the liquid level reaches the valve's lower portion, the lower float is lifted, pushing the sealing mechanism to its sealing position.
3. The entrapped air is confined in a pocket between the liquid and the sealing mechanism. The air pressure is equal to the system pressure.
4. Increases in system pressure compress the trapped air in the upper section of the conical chamber. The conical shape assures the height of the air gap. This enables separation of the liquid from the sealing mechanism.
5. Entrapped air (gas), accumulating at peaks and along the system, rises to the top of the valve and displaces the liquid in the valve's body.
6. When the liquid level lowers to a point where the float is no longer buoyant, the float drops, unsealing the rolling seal. The air release orifice opens and allows part of the air that accumulated in the upper portion of the valve to be released to the atmosphere.
7. Liquid enters the valve. The float rises, pushing the rolling seal to its sealing position. The remaining air gap prevents the wastewater from fouling the mechanism.

When internal pressure falls below atmospheric pressure (negative pressure):

1. The floats will drop down, immediately opening the air & vacuum and air release orifices.
2. Air will enter into the system.

Main Features

- Working pressure range: 0.05 - 10 bar.
- Testing pressure: 16 bar.
- Maximum working temperature: 60° C.
- Maximum intermittent temperature: 90° C.
- The unique design of the valve prevents contact between the wastewater and the sealing mechanism by creating an air gap at the top of the valve. These features are achieved by:
 - **The conical body shape:** designed to maintain the maximum distance between the liquid and the sealing mechanism and still obtain minimum body length.
 - **Independent spring-guided linkage between the lower float/rod assembly and the upper float sealing mechanism:** allows free movement of the float and rod. Vibrations and movement of the lower float due to turbulence will not unseal the upper float sealing mechanism.
 - **The Rolling Seal Mechanism:** less sensitive to pressure

differentials than a direct float seal. It accomplishes this by having a comparably large orifice for a wide pressure range (up to 10 bar).

- **Funnel-shaped lower body:** designed to ensure that residue wastewater matter will fall back into the system and be carried away by the main pipe.

- All inner metal parts made of stainless steel. Float made of composite materials.
- 1 1/2" threaded discharge outlet enables connection of a vent pipe.
- Dynamic design allows for high capacity air discharge while preventing premature closure.
- The ball valve can be opened to release trapped pressure and drain the valve body prior to maintenance and for back-flushing during maintenance.

Valve Selection

- These valves are available in 2", 3", and 4" with a BSP/NPT male threaded connection or flanged, standard upon request.
- Valve is manufactured in reinforced nylon, also available in stainless steel or ductile iron.
- With a One-way, Out-only attachment, allows for air discharge only, prevents air intake.
- With a Vacuum Breaker, In-only attachment, allows for air intake only, prevents air discharge.
- With a Non-Slam discharge-throttling attachment, allows for free air intake, throttles air discharge.

Note

- The D-025 air valve is intended for use with raw wastewater. For use with aggressive liquids, please consult with our application engineers or with the marketing dept.
- For best suitability, it is recommended to send the fluid chemical properties along with the valve request.
- Upon ordering, please specify: model, size, working pressure, thread and flange standard and type of liquid.

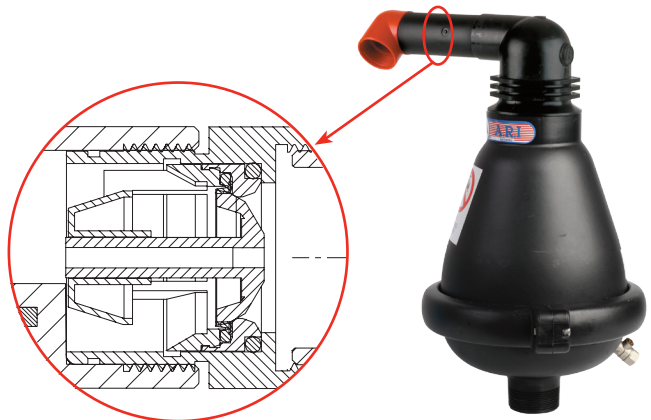

D-025-NS

D-025 Non-Slam Single Orifice Add-on Component Data Table

Nominal Size	Discharge orifice	Total NS area	NS orifice	Switching point	Flow at 0.4 bar
2" (50mm)	37.5 mm	12.6 mm ²	4 mm	Spring loaded normally closed	17.5 m ³ /h
3" (80mm)					
4" (100mm)					

AIR AND VACUUM FLOW RATE

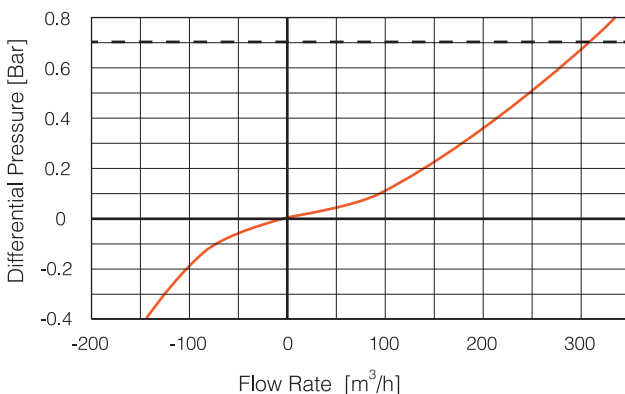

--- Max. recommended design air discharge

AUTOMATIC AIR RELEASE FLOW RATE

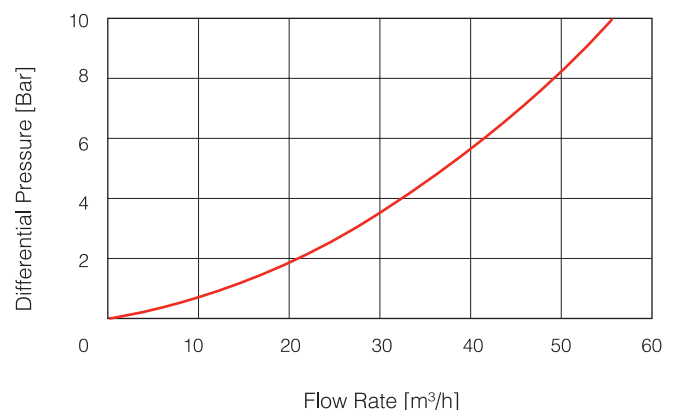

DIMENSIONS AND WEIGHTS

Nominal Size	Dimensions mm		Connection C	Weight Kg.			Orifice Area mm ²	
	A	B		RN	ST	ST	DI	Auto.
2" (50mm) Threaded	370	455	1½" BSP Female	3.8	14.4	14.4	12	804
2" (50mm) Flanged	370	460	1½" BSP Female	4.2	16.2	16.2	12	804
3" (80mm) Threaded	370	455	1½" BSP Female	3.8	14.7	14.7	12	804
3" (80mm) Flanged	370	460	1½" BSP Female	5.4	16.5	16.5	12	804
4" (100mm) Threaded	370	455	1½" BSP Female	3.9	16.6	16.6	12	804
4" (100mm) Flanged	370	460	1½" BSP Female	6.0	18.4	18.4	12	804

PARTS LIST AND SPECIFICATION

No. Part	Material
1. Air Release Outlet	Polypropylene
2. Rolling Seal Assembly	RN + EPDM + ST ST
3. Float	Foamed Polypropylene
4. Clamping Stem	Reinforced Nylon
5. Body	Reinforced Nylon / Stainless Steel 316
6. Domed Nut	Stainless Steel 316
7. O-Ring	BUNA-N
8. Stopper	Polypropylene
9. Spring	Stainless Steel 316
10. Washer	Stainless Steel 316
11. Float Stem	Stainless Steel 316
12. Body	Reinforced Nylon / Ductile Iron / Stainless Steel 316
13. Clamp	RN Body Reinforced Nylon + Stainless Steel 316 ST ST/ DI Body Stainless Steel 316
14. O-Ring	BUNA-N
15. Float	Foamed Polypropylene
16. Tap 1/4 "	Brass / Stainless Steel
17. Washer	Stainless Steel 316
18. Base	Reinforced Nylon / Ductile Iron / Stainless Steel 316
19. Flange	Reinforced Nylon / Ductile Iron / Stainless Steel 316

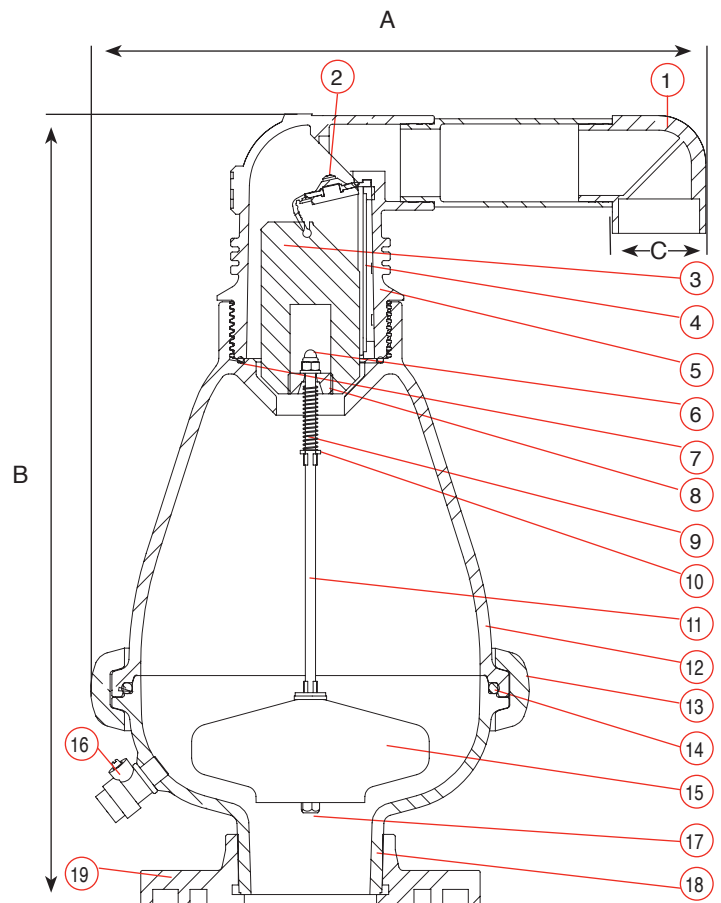

* in STST or DI Body, the flange is an integral part of the base.

