



STANDARD PIPE NIPPLES

Form #1221

Type - Black & Galvanized, Std. Sch. 40, XH Sch. 80, Sch. 160, XXH

UNCONTROLLED
COPY

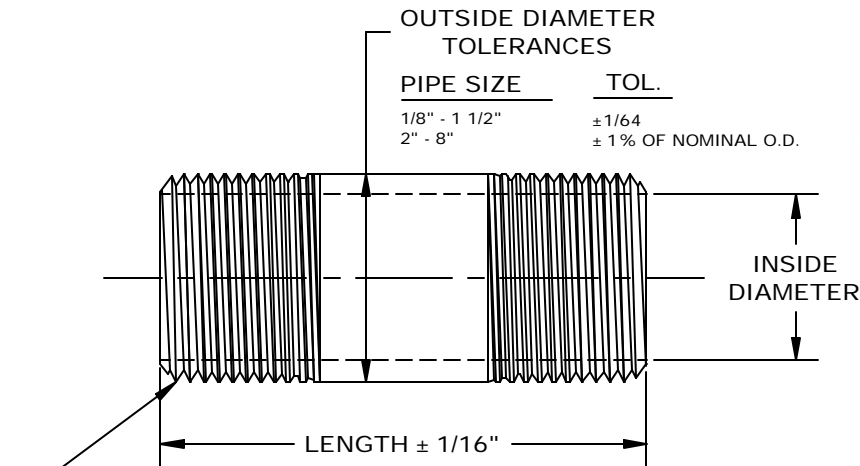

Standard NPT Tapered Pipe Threads as per ANSI B 1.20.1 Specification.

Material - ASTM A53 Standard Specification for Pipe Steel, Black, Hot-Dipped, Zinc Coated, Welded and Seamless.

APPLICABLE SPECIFICATION: ASTM A733

(Refer to Form#0053 for specific pipe dimensions.)

NOTE:

MINIMUM WALL THICKNESS AT ANY POINT TO BE NOT MORE THAN 12.5 % UNDER NOMINAL WALL THICKNESS SPECIFIED FOR THAT SIZE PIPE.

Pipe Size (in.)	Pipe O.D. (in.)	Length Close (in.)	Pipe Nipple Lengths																
			1-1/2	2	2-1/2	3	3-1/2	4	4-1/2	5	5-1/2	6	7	8	9	10	11	12	
1/8	.405	3/4	1-1/2	2	2-1/2	3	3-1/2	4	4-1/2	5	5-1/2	6	7	8	9	10	11	12	
1/4	.540	7/8	1-1/2	2	2-1/2	3	3-1/2	4	4-1/2	5	5-1/2	6	7	8	9	10	11	12	
3/8	.675	1	1-1/2	2	2-1/2	3	3-1/2	4	4-1/2	5	5-1/2	6	7	8	9	10	11	12	
1/2	.840	1-1/8	1-1/2	2	2-1/2	3	3-1/2	4	4-1/2	5	5-1/2	6	7	8	9	10	11	12	
3/4	1.050	1-3/8	1-1/2	2	2-1/2	3	3-1/2	4	4-1/2	5	5-1/2	6	7	8	9	10	11	12	
1	1.315	1-1/2		2	2-1/2	3	3-1/2	4	4-1/2	5	5-1/2	6	7	8	9	10	11	12	
1-1/4	1.660	1-5/8		2	2-1/2	3	3-1/2	4	4-1/2	5	5-1/2	6	7	8	9	10	11	12	
1-1/2	1.900	1-3/4		2	2-1/2	3	3-1/2	4	4-1/2	5	5-1/2	6	7	8	9	10	11	12	
2	2.375	2			2-1/2	3	3-1/2	4	4-1/2	5	5-1/2	6	7	8	9	10	11	12	
2-1/2	2.875	2-1/2				3	3-1/2	4	4-1/2	5	5-1/2	6	7	8	9	10	11	12	
3	3.500	2-5/8					3	3-1/2	4	4-1/2	5	5-1/2	6	7	8	9	10	11	12
4	4.500	2-7/8						4	4-1/2	5	5-1/2	6	7	8	9	10	11	12	
5	5.563	3							4-1/2	5	5-1/2	6	7	8	9	10	11	12	
6	6.625	3-1/8								4-1/2	5	5-1/2	6	7	8	9	10	11	12

2/28/00

Revision 1
R.T. Bryson

NOTE: Other lengths available