



# TWIN-FLO III<sup>®</sup> HEATER

## INSTALLATION INSTRUCTIONS • TYPE K

**ATTENTION: READ THESE INSTRUCTIONS CAREFULLY BEFORE ATTEMPTING TO INSTALL, OPERATE, OR SERVICE THE BEACON MORRIS TWIN-FLO III HEATERS! RETAIN THESE INSTRUCTIONS FOR FUTURE REFERENCE.**

**INSPECT THE SHIPMENT IMMEDIATELY WHEN RECEIVED TO DETERMINE IF ANY DAMAGE HAS OCCURRED DURING SHIPMENT.**

**PRIOR TO INSTALLATION, CHECK FOR ANY VISIBLE DAMAGE. MAKE CERTAIN THAT ANY LOOSE PARTICLES ARE REMOVED (ESPECIALLY IN THE BLOWER ASSEMBLY AREA). SAFE TO USE WITH POTABLE WATER.**

### GENERAL DESCRIPTION

TWIN-FLO III heaters are for use with forced hot water residential heating systems and consist of a copper tube, aluminum finned heating element, with an electric motor and blower of unique cross flow design. Their purpose is to deliver a comfortable stream of warmed air, at or near floor level, and their construction is extremely compact so minimum space is required for installation. The type K heater is primarily used in horizontal floor installation, for example: under a kitchen counter cabinet, or bathroom sink enclosure. They are ideal for radiant systems with the use of a low temperature aquastat designed to turn the unit on at 110°F. Type W is for vertical mounting, fully recessed in the wall studs, with the air discharged upward through a flush mounted, louvered front panel. Type F is a surface mounted wall unit, with the air discharged evenly through a louvered front panel in an upward direction. All types have heating elements with 1/2" nominal (5/8 O.D.) copper tube connections, and 115V. electric blower motor, interwired with a 120°F (49°C) reverse acting aquastat that prevents operation until hot water is circulating. These units are **NOT** intended to be used on one or two pipe steam systems. See bottom of page 5. For gravity fed systems, it is recommended that a separate circulator pump be installed for the kick space heater.

### INSTALLING TWIN-FLO III TYPE K

1. Select a location under the bottom shelf of a cabinet that meets the minimum dimensions shown in Fig. 1.
2. **CUT AN ACCESS PANEL THROUGH THE BOTTOM OF THE CABINET AT THIS LOCATION, LARGE ENOUGH FOR INSTALLATION AND SERVICE. IT IS RECOMMENDED THAT THIS ACCESS PANEL BE CONSTRUCTED SO ANNUAL CLEANING OF THE BLOWER FAN AND COIL FINS CAN BE EASILY ACCESSIBLE.**
3. **At this location, center and cut an opening in the toe-space riser 4" high x 11" long (Model K42 see Figure 1) or 4" high x 18" long (Model K84 see Figure 2) or 4" high x 23" long (Model K120 see Figure 3).**
4. **Set the TWIN-FLO III in the space at finished floor level** and check piping and wiring locations. The air outlet should be facing but not extending beyond the toe-space riser at the opening. The air outlet should also be located at the bottom portion of the 4" toe-space riser (See figure A) at finished floor level. Make sure the switch is accessible through the grille openings. The front of the unit should fit flush to the inside of the toe space riser.
5. Install the grille over the 4" toe-space opening with the two screws provided.
6. If using the TWIN-FLO "Easy Connect" Flexible Hose Connection Kit, see those installation instructions.
7. Next, prepare the heating element for pipe connections (this procedure will also pertain to Model types W and F). Remove the 3 screws from the electric conn. box. Unsnap (pull) the thermostat clamp from the return copper U-bend. Holding down the top cover, remove the 4 element cover screws. Carefully remove this top cover noting the position of the element and the neoprene side pad. Lift out the element for soldering and fittings. Both ends are sized to accept 1/2" solder fittings. (Note required fittings for one pipe and two pipe systems on page 4).
8. Replace the heating element in the bottom cover in the proper position. Place the neoprene side pad in position and replace the top cover using the 4 screws. Tighten enough to keep the element in place between the covers. **DO NOT OVER-TIGHTEN!**
9. Place the TWIN-FLO III under the cabinet and connect the piping and wiring. **Make sure unit & outlet are free of any dirt or debris prior to start up.** Turn on the system, purge of air, check blower operation and check for any possible leaks in the piping (run for 2 hrs. minimum). It should then be screwed to the floor through the four resilient mounting feet (2-inside electrical box and 2 external). Do not over-tighten screws. Secure top of electrical box.



# DIMENSIONAL DATA

## TWIN-FLO III TYPE K42

FIGURE 1

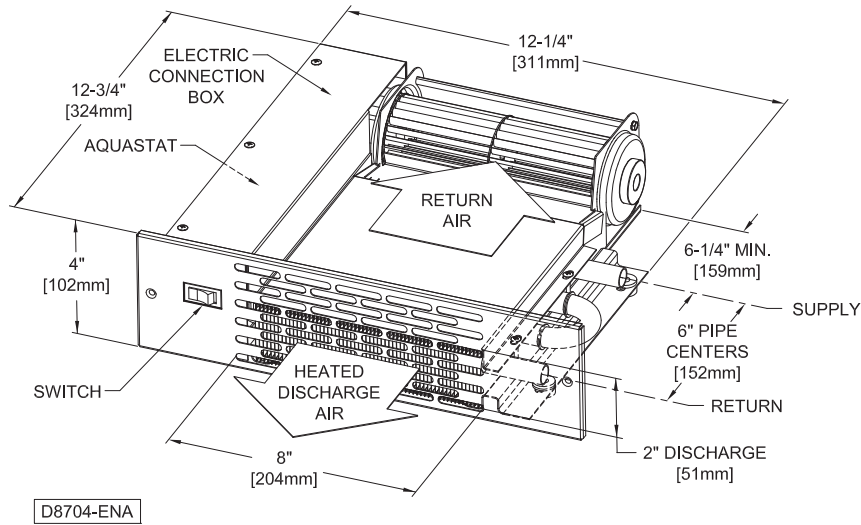

## TWIN-FLO III TYPE K84

FIGURE 2

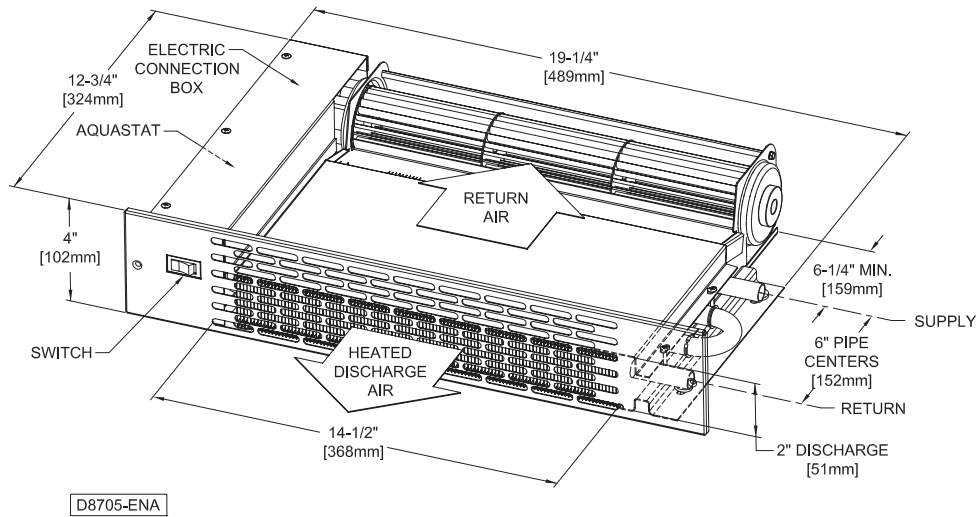

## TWIN-FLO III TYPE K120

FIGURE 3

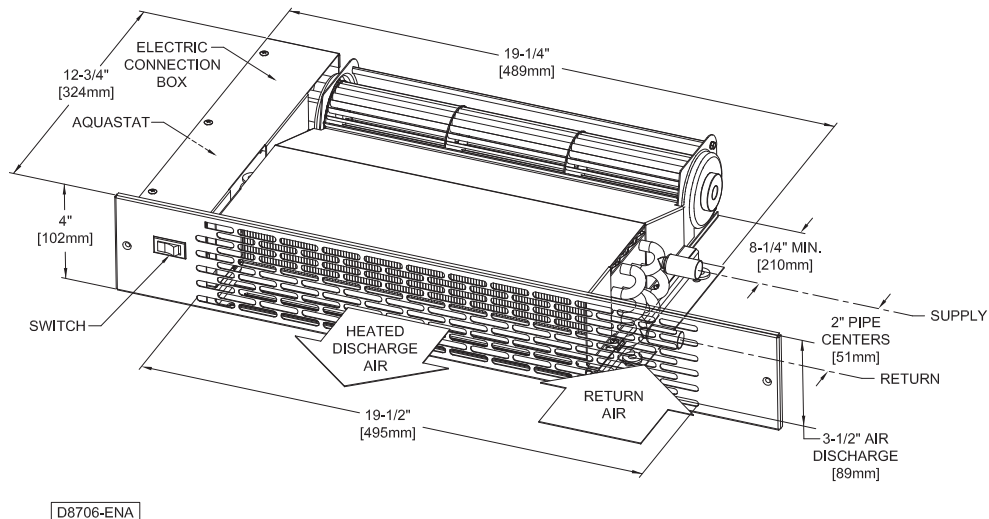

Dimensions shown in English and metric ( ).

# ELECTRICAL CONNECTIONS

**CAUTION! For Supply Connections, use wires suitable for at least 194°F (90°C).**

**All electrical connections must conform to local and national codes.**

A shaded pole motor is used to drive the Twin-Flo III blower on 115 -120 V. 60 hz. Since current drain is very small, wiring codes for short circuit protection only will apply. The motor is connected in series with a normally open aquastat in contact with the heating element. Therefore, the blower runs only when unit is sufficiently hot and the switch is in the "min" or "max" position (not "off"). A ground screw is supplied with all units.

Electrical connections are to be made to all units following the diagrams below. Choose the diagram that best suits your application.

Since the blower runs on all Twin-Flo III models only when the system circulator pumps hot water through the unit, simply connect it to the 115 V line. The blower then starts after a short warm-up, and stops a few minutes after the circulator shuts off (see diagram A).

Adding a line voltage type room thermostat will permit the setting of a maximum room temperature (see diagram B). This 'T' stat will only operate the kickspace unit. If the circuit or system circulator is not running, the kickspace heater will not operate.

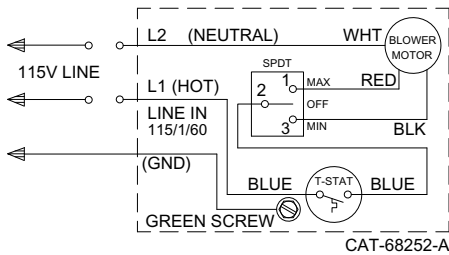

**WIRING DIAGRAM A**

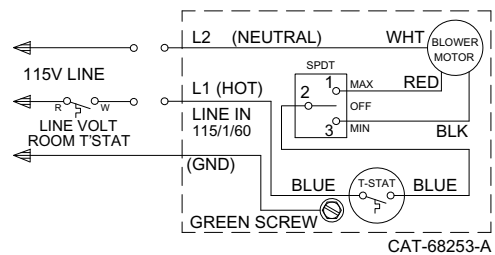

**WIRING DIAGRAM B**

Connection through a circulator or zone auxiliary switch may also be used to permit instant shutdown of the blower as the circulator stops (see diagram #3).

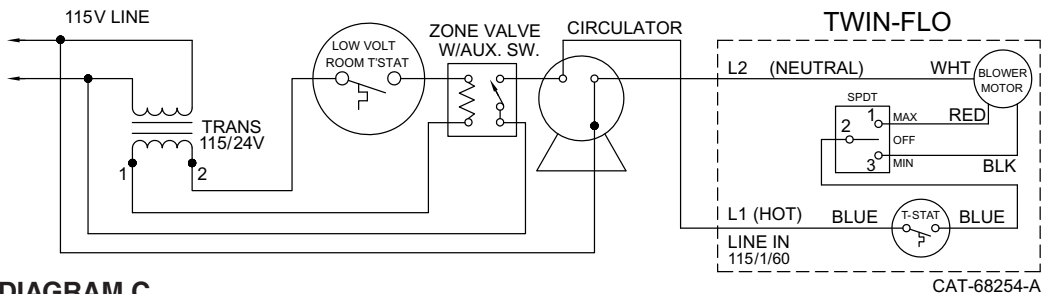

**WIRING DIAGRAM C**

MOTOR INFORMATION						
UNIT	AMP	WATT	RPM	HP	VOLTAGE	CFM (HIGH SPEED)
K-42	.50	30.7	3200	.034	115	53
K-84	.50	30.7	3200	.034	115	103
K-120	.74	66.8	3200	.068	115	127

FRICTION LOSS (HEAD)			
	K42	K84	K120
1 GALLON	.17'	.22'	.43'
2 GALLONS	.8'	.95'	1.45'
3 GALLONS	1.2'	1.5'	2.97'

## SYSTEM CONSIDERATIONS

Beacon/Morris Twin-Flo III Heaters should be connected only to circulating **hot water systems** where at least 1 gpm water flow is expected. They are essentially small unit heaters, and will work on one or two pipe systems, or in a series loop where pressure and temperature drop can be tolerated (see capacity charts and piping diagrams). These units are not designed for use with steam systems. See bottom paragraph on page 7. These units are not recommended to be used with a gravity flow system. Series loop systems do not require scoop or venturi tees.

### Piping Charts

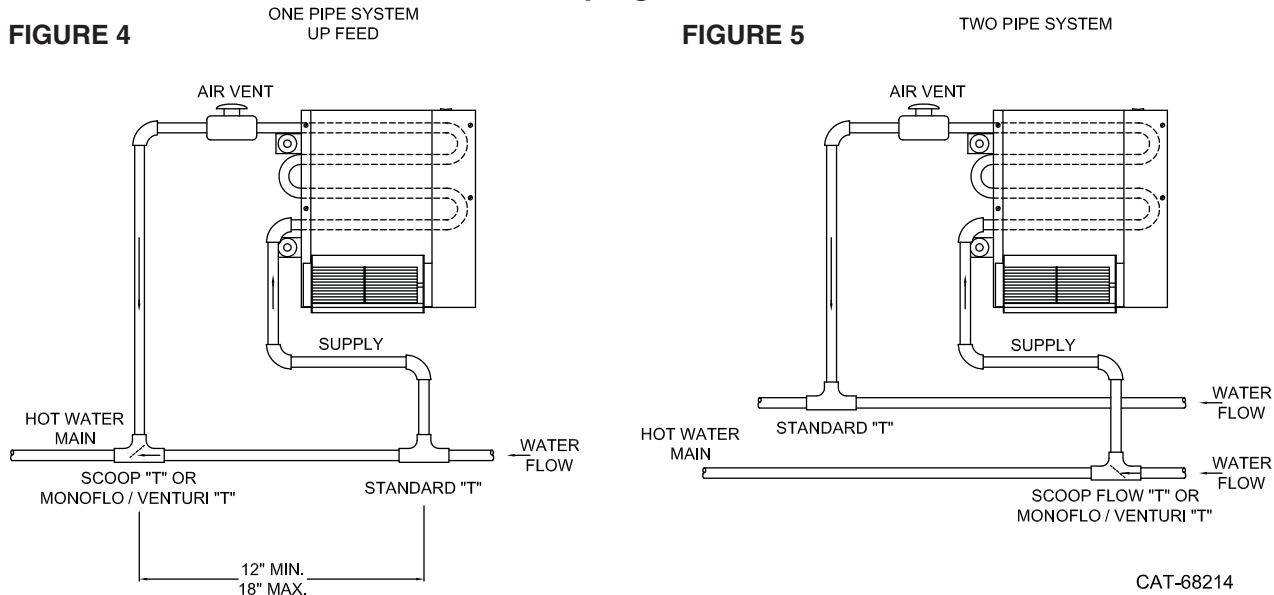

Installation should be done with as few fittings as possible. Multiple fittings may cause too much resistance.

**NOTE:** In an up feed system, unit is located above hot water supply line. In a down feed system, unit is located below hot water supply line.

For One Pipe System Down Feed, two directional flow tees should be used. They should be spaced 12 to 18" apart. To better understand directional flow tee installation, refer to page 5.

If directional flow tee's are not available, an adjustable screw operated flow control or circuit setter can be placed between the two standard tee's in a one pipe system.

For consistent response of the reverse acting thermostat, and effective outlet air temperature, the average water temperature should not be below 120°F (49°C). Blower motor shuts off at 105°F (41°C) and will not operate until water temperature reaches 120°F (49°C).

If utilizing water temperature below 120°F (49°C), the blower will not operate with the self contained aquastat. An optional low temperature aquastat, 110° to 95°F (43° to 35°C) is available.

## MAINTENANCE & SERVICE

Properly installed, the Beacon/Morris TWIN-FLO III heater should require very little attention. Since the heating element is carefully constructed and tested, and of non-ferrous materials, it should never require service. The cross-flow blower has been thoroughly engineered, with ball bearings for 10,000 hrs. bearing life expectancy. **As with any electrical rotating device, a yearly inspection and cleaning is recommended.** Whenever there is air movement, there will be some accumulation of dust and lint. In this case it will collect on the rotor blades and air passage of the unit. Regular cleaning with a vacuum cleaner tool is advised, with frequency determined by prevailing conditions. **Always make sure that the air grille is not blocked by foreign objects or materials.**

## DIRECTIONAL FLOW TEE INSTALLATION USING SCOOP OR VENTURI TEES

When installing a Twin-Flo Kickspace heater it is recommended that a directional flow tee be installed on the return piping of the unit. For one pipe up feed systems, one tee installed on the return should be sufficient. For one pipe down feed systems, the application will require a tee on the supply and return piping. Series loop systems do not require scoop or venturi tees. Consult your heating professional for your specific application as some one pipe up feed systems will require two tees.

### What is a directional flow Tee?

There are two types of directional flow tees, scoop style and venturi style. When installing a scoop tee on the supply side, the arrow on the tee should point in opposition to water flow\* (opposite direction of return installation). This will direct water up into the kickspace heater (Figure 6). The scoop tee, when installed on the return, will direct the water back to the return piping on the system and create a pressure drop towards the supply tee forcing water up into the unit. The arrow on the tee should point in the direction of water flow\* (Figure 7).



Figure 6 (cutaway)



Figure 7 (cutaway)

A venturi style tee has an internal cone. Our illustrations show a B&G monoflo (venturi) tee. The red ring on the tee should always be installed between the risers, regardless of return or supply installation. Figure 8 is a supply installation. Figure 9 shows installation for the return side (red ring between risers). The return tee is installed opposite of the supply tee with the red ring between the risers when two tees are used.

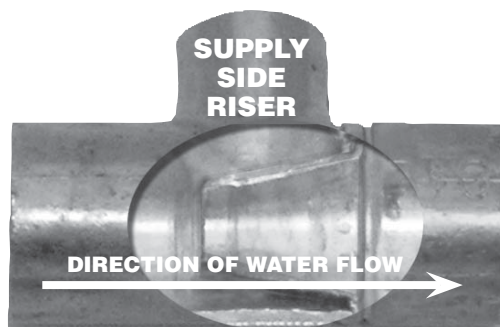

Figure 8 (cutaway)

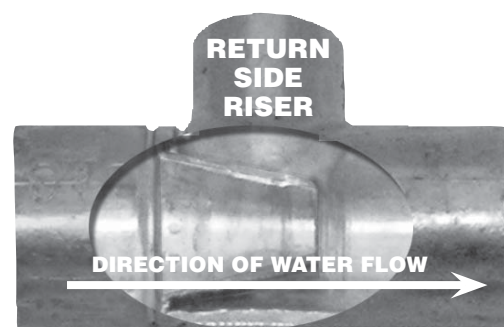

Figure 9 (cutaway)

For any questions on your installation, please consult your local plumber or plumbing supply house.

\*Due to various manufacturers of scoop tees, look inside the tee to verify the orientation of the scoop to ensure proper installation.

# Twin-Flo III Troubleshooting

## 1. If Kickspace heater does not turn on check below for possible solutions:

### A. Verify the following:

- a) Check to see if there is a call for heat
  - Turn up thermostat, wait for water to come up to temperature and unit blower/motor should turn on.
- b) Verify aquastat is clipped firmly to copper tube. Clip may become loose during shipping. Located under electrical box cover.
- c) Check for power switch to be in low or high position
  - Switch in front of unit should be switched to the left or right, middle position is off.
- d) Check for power to the unit (115v) with voltmeter
- e) Check supply piping to see if its hot
  - If piping isn't hot, water is not getting into the kickspace heater check the directional flow tee and piping installation (see pages 4 and 5 for help with tee installation).

## 2. If above criteria have been verified and unit will still not turn on try the following:

**Jumper out (by-pass) the aquastat; this should be done by a licensed electrician.**

### A. If blower turns on check below for possible solutions:

- a) Water is not hot enough
  - Check system water temp. If radiant system, low temperature aquastat may be needed.
- b) Water not circulating fast enough
  - Kickspace heaters must have at least 1GPM flow to operate properly. If system circulator is not running kickspace heater will not turn on.
- c) Water not getting into kickspace heater (supply line not hot)
  - need to check installation piping and directional flow tee arrangement (see pages 4 and 5)
  - Possible air problem – bleed air from unit
- d) Thermostat wired to unit not working properly
- e) Aquastat is not functioning properly
  - Replace aquastat

### B. If blower does not turn on:

- a) Check all electrical connections
- b) Blower motor may be defective

After going through these steps, if the unit still fails to operate, contact your local heating & plumbing contractor.

### 3. Noisy blower motor:

- Blower may have shifted during shipping/installation. A screwdriver may be used to push the blower away from the motor. Simply insert a screwdriver between blower (end closest to electrical box) and blower housing, and gently push blower away from housing.

# REPLACEMENT PARTS LIST

Description	Part No.	Model		
		42	84	120
Motor-Fan Assembly	BMKR02020-001	x		
	BMKR02020-002		x	
	BMKR02020-003			x
Standard Aquastat Assembly (120° – 105°F)	BMKR02024-001	x	x	
	BMKR02024-002			x
Low Temp. Aquastat Assembly (110° – 95°F)	BMKR0204-L01	x	x	
	BMKR0204-L02			x
Heating Element	BMKR02017-001	x		
	BMKR02017-002		x	
	J37R52064			x
2 Speed Fan Switch	J11R02029-001	x	x	x
Outlet Grille w/ screws (Model K only) (Black)	BMKR08778-B42	x		
	BMKR08778-B84		x	
	BMKR08778-B12			x
Louvered Front Panel (Model W only)	BMWR02172-001	x		
	BMWR02172-002		x	x
Louvered Front Panel (Model F only)	BMFR02165-001	x		
	BMFR02165-002		x	x
Louvered Front Panel (Model FK only)	FKR02437-001	x		
	FKR02437-002		x	x

# ACCESSORIES

Description	Part No.	Model		
		42	84	120
Quick-Connect Hose Kit	HK-10	x	x	x

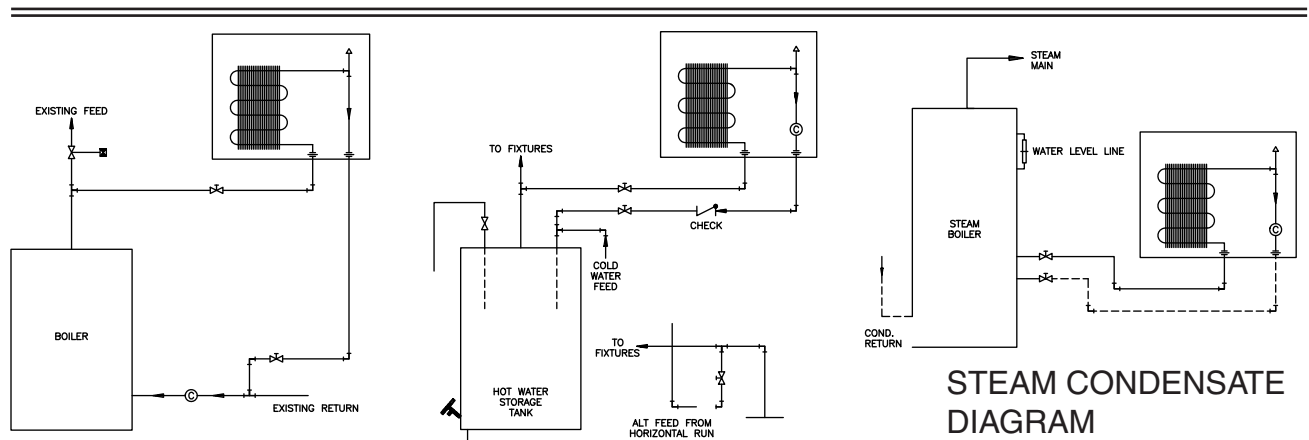

On a typical forced hot water system, connect return to inlet side of circulator and supply upstream of remotely operated valve. Unit may also be connected to mains of an existing loop system of sufficient capacity. Operation will be influenced by the system circulator and associated controls.

Installation of a pump and line voltage thermostat will provide the unit with its own “zone” control.

With the addition of a circulator pump, hot water storage tanks may be used (where codes permit) as a supply source if proper precautions are taken, and if relatively low water temperatures can be tolerated. Be sure tank can supply additional load of the Twin-Flo and 120°F water. Supply is taken from top of tank, and returns at the cold water inlet with a check valve. Do not return to bottom drain tapping.

Operation from steam boiler water is entirely possible as long as supply and return connection is installed below level of water line on a steam boiler. This installation requires an optional circulator pump and line voltage thermostat. Check local building codes.

## LIMITED WARRANTY

### Twin-Flo III Heaters

The "Manufacturer" warrants to the original owner at the original installation site that the Twin-Flo Kickspace Heaters (the "Product") will be free from defects in material or workmanship for five (5) years from the date of shipment from the factory. If upon examination by the Manufacturer the Product is shown to have a defect in material or workmanship during the warranty period, the Manufacturer will repair or replace, at its option, that part of the Product which is shown to be defective.

This limited warranty does not apply:

- (a) if the Product has been subjected to misuse or neglect, has been accidentally or intentionally damaged, has not been installed, maintained or operated in accordance with the furnished written instructions, or has been altered or modified in any way.
- (b) to any expenses, including labor or material, incurred during removal or reinstallation of the defective Product or parts thereof.
- (c) to any workmanship of any installer of the Product.

This limited warranty is conditional upon:

- (a) shipment, to the Manufacturer, of that part of the Product thought to be defective. Goods can only be returned with prior written approval from the Manufacturer. All returns must be freight prepaid.
- (b) determination, in the reasonable opinion of the Manufacturer, that there exists a defect in material or workmanship.

Repair or replacement of any part under this Limited Warranty shall not extend the duration of the warranty with respect to such repaired or replaced part beyond the stated warranty period.

**THIS LIMITED WARRANTY IS IN LIEU OF ALL OTHER WARRANTIES, EITHER EXPRESS OR IMPLIED, AND ALL SUCH OTHER WARRANTIES, INCLUDING WITHOUT LIMITATION IMPLIED WARRANTIES OF MERCHANTABILITY OR FITNESS FOR A PARTICULAR PURPOSE, ARE HEREBY DISCLAIMED AND EXCLUDED FROM THIS LIMITED WARRANTY. IN NO EVENT SHALL THE MANUFACTURER BE LIABLE IN ANY WAY FOR ANY CONSEQUENTIAL, SPECIAL, OR INCIDENTAL DAMAGES OF ANY NATURE WHATSOEVER, OR FOR ANY AMOUNTS IN EXCESS OF THE SELLING PRICE OF THE PRODUCT OR ANY PARTS THEREOF FOUND TO BE DEFECTIVE. THIS LIMITED WARRANTY GIVES THE ORIGINAL OWNER OF THE PRODUCT SPECIFIC LEGAL RIGHTS. YOU MAY ALSO HAVE OTHER RIGHTS WHICH MAY VARY BY EACH JURISDICTION.**



260 NORTH ELM STREET, WESTFIELD, MASSACHUSETTS 01085  
7555 TRANMERE DRIVE, MISSISSAUGA, ONTARIO L5S 1L4 CANADA