

Single-Appliance Connectors

1. Make sure the Type B gas vent is securely mounted and that it protrudes into the appliance room (see Figure 1). The connector must not penetrate any combustible ceiling or wall.
2. Connect the flexible gas connector section (that most closely matches the correct length) to the B-Vent fitting or pipe protruding into the room (see Figure 1 and Figure 2).
3. Alternate ways of connecting to the Type B gas vent. Involve the use of a tee and a tee cap (see Figure 2), or a wye and a tee cap (see Figure 3).
4. Once the connector is locked in place, bend the connector to the general location of the appliance. Note: If the connector is too long, **do not** cut the connector; rather, compress the connector to the right length (see Figure 1).
5. Connect to the appliance. The connector may be directly connected to the appliance, but a draft hood connector is recommended. Screw the draft hood connector to the draft hood or collar, and connect the flexible connector to the draft hood connector (see Figure 4).
6. The vent connector system is now completely secured and aligned with the least possible resistance.

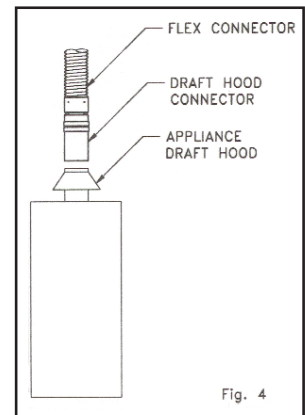
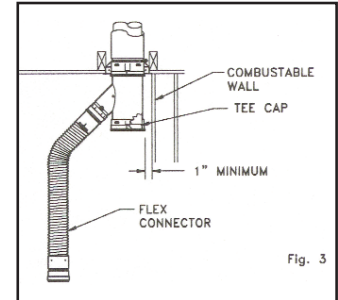

Multiple-Appliance Connectors

1. If more than one appliance is connected to a common vent, a tee or wye may be used (see Figure 5 and Figure 6).
2. As in the single-connector system, the wye or tee may be connected to almost any brand of B-Vent with the use of an adapter.
3. The remaining steps are exactly the same as those for the single-appliance connector system.

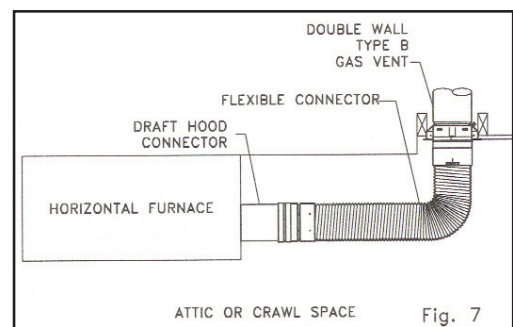
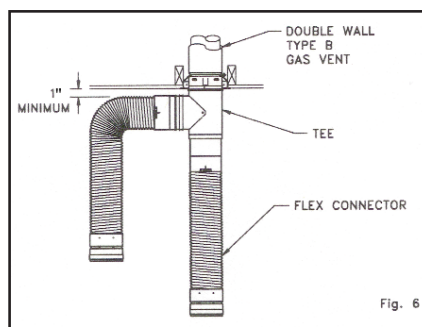
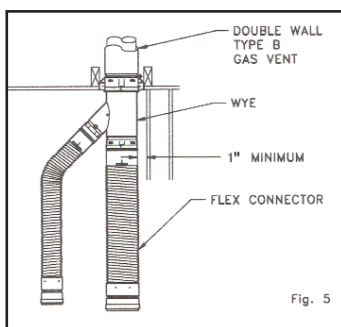

5030 Corporate Exchange Blvd SE
Grand Rapids, MI 49512
www.hartandcooley.com

P: 800-433-6341
P: 616-656-8200
F: 616-656-6397
info@hartcool.com

Model DFC Double-Wall Gas Vent Connector Installation Instructions

Please read and understand the requirements before proceeding.

This double-wall gas vent connector may be used as a connector for listed gas appliances equipped with a draft hood or other appliances listed for use with Type B gas vent. It may be used to connect appliances to B-Vent in unconditioned spaces. This includes Category I furnaces, boilers and water heaters. These gas appliances may be connected singly or in multiples, as long as the connectors are properly sized, using the appliance manufacturer's instructions and the National Fuel Gas Code NFPA 54.

This product is a Type B gas vent connector and may be used in applications where Type B gas vent is required; for instance, connecting an appliance to a vent in an unconditioned space (see Figure 7). Do not totally enclose. Do not pass through combustible walls, floors, or ceilings. One-inch (1") minimum airspace clearance is required for combustibles and insulation.

General Installation Guidelines

1. This product shall be sized according to the gas appliance instructions and the National Fuel Gas Code NFPA 54. An alternate sizing method allows the effective area of the connector to be not less than the area of the draft hood or outlet collar.
2. This connector should be generally installed as follows:
 - a. In as short and straight a run as possible with no unnecessary bends.
 - b. Without any dips or sags.
 - c. Slope upwards at least $\frac{1}{4}$ " per foot.
 - d. No bends greater than 90 degrees.
3. This gas vent connector is designed to be used with Hart & Cooley B-Vent (see B-Vent installation instructions). The end fittings connect directly to Hart & Cooley B-Vent products. Installation does not require the use of sheet metal screws. A universal adapter would be used to connect to other brands of B-Vent.
4. This flexible gas vent connector is UL-listed for installations where double-wall gas vent connectors are acceptable.
5. Do not cut or modify the flexible pipe. The lengths will compress approximately 4" per foot. If the flexible pipe is too long, shorten by compressing. Note: Compression will not affect the venting performance but will reduce the flexibility of the connector. Two pieces may be connected together if a longer connector is desired. These should be supported at 5-foot maximum intervals.
6. The flexible material is made from a special alloy, .012 thick aluminum. Use only Hart & Cooley-listed flex material.
7. When making a bend in a connector, do not bend over sharp edges. Make the bend as smooth as possible.
8. This gas vent connector is tested and listed by UL for one-inch (1") clearance to combustibles and to insulation in an unenclosed installation. Vent pipe hangers made from plumber's strap and a wall bracket (RWB) should be used at each end of a flexible length that is not attached to a fixed point; i.e., an appliance outlet.

