

Gray Metal Products - Product Data Sheet (PDS)

Product No. 400A
Round Adhesive Takeoff w/No Damper

Body: 26 Gauge
Flange: 30 Gauge w/ Mounting Holes

All measurements are in inches

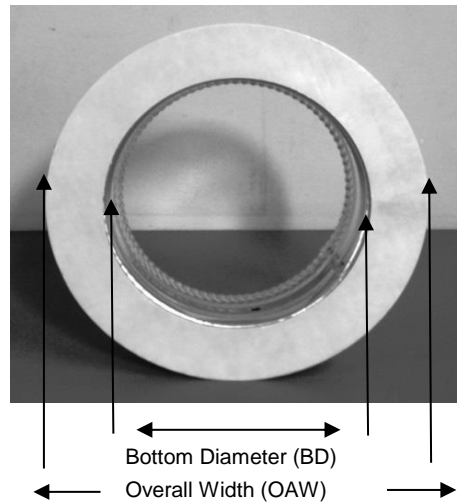
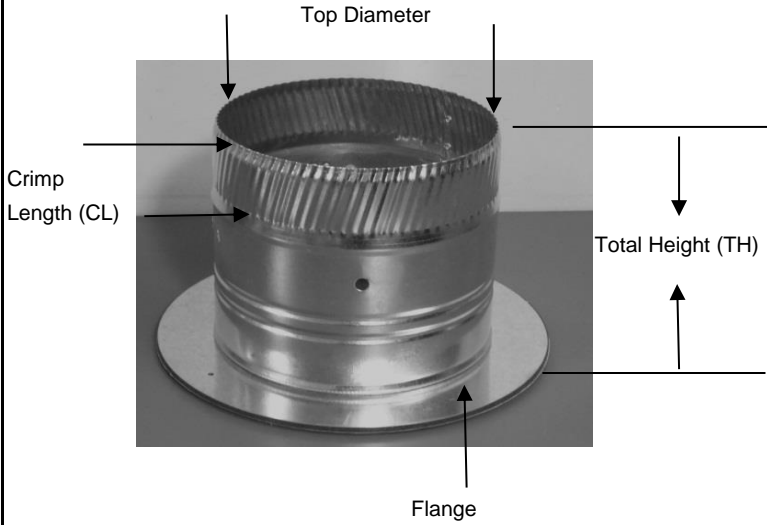

Part	TD	BD	CL	TH	FLG	OAW
4- 400A	4"	4"	1 1/2"	5 5/8"	1 1/2"	7"
5- 400A	5"	5"	1 1/2"	5 5/8"	1 1/2"	8"
6- 400A	6"	6"	1 1/2"	5 5/8"	1 1/2"	9"
7- 400A	7"	7"	1 1/2"	5 5/8"	1 1/2"	10"
8- 400A	8"	8"	1 1/2"	5 5/8"	1 1/2"	11"
9- 400A	9"	9"	1 1/2"	5 5/8"	1 1/2"	12"
10- 400A	10"	10"	1 1/2"	5 5/8"	1 1/2"	13"
12- 400A	12"	12"	1 1/2"	5 5/8"	1 1/2"	15"
14- 400A	14"	14"	1 1/2"	5 5/8"	1 1/2"	17"
16- 400A	16"	16"	1 1/2"	5 5/8"	1 1/2"	19"
18- 400A	18"	18"	1 1/2"	5 5/8"	1 1/2"	21"
20- 400A	20"	20"	1 1/2"	5 5/8"	1 1/2"	23"

Tolerance = plus or minus .125" (1/8")