

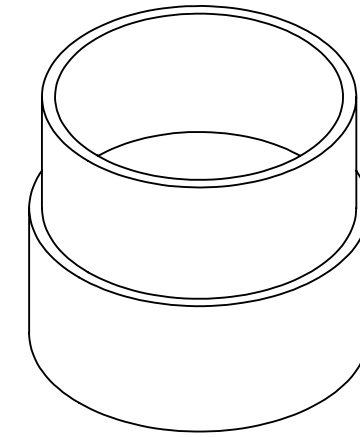

300 S. DAYTON ST.  
 DAVISON, MI 48423  
 PH: 810-653-9626  
 FAX: 810-654-2616

# DSC-33

DESCRIPTION: Downspout Connector 3" Drain x 3" Round or 3"x2" Rectangle or 2.5" Square

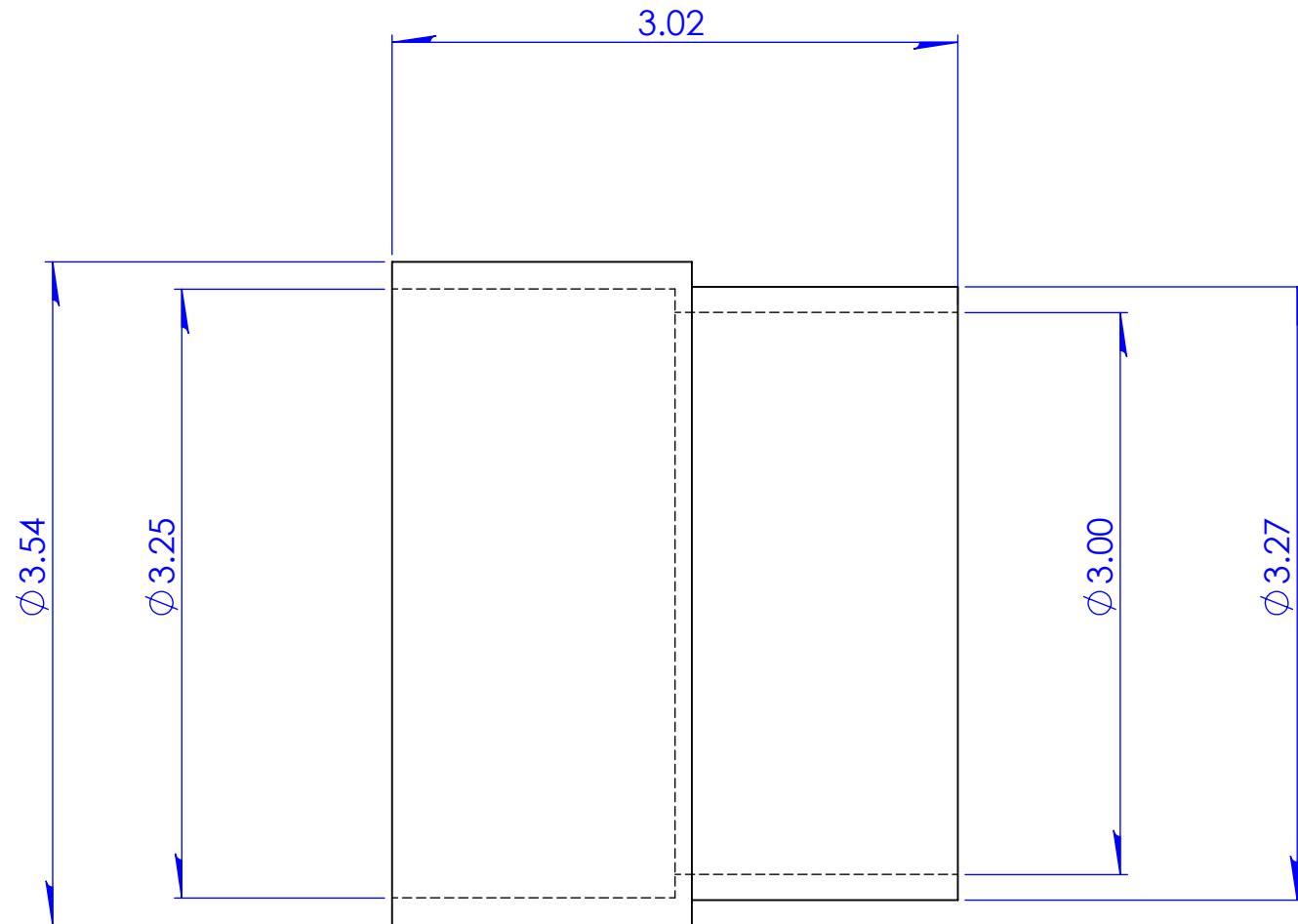

PROPRIETARY AND CONFIDENTIAL  
 THE INFORMATION CONTAINED IN THIS  
 DRAWING IS THE SOLE PROPERTY OF  
 FERINCO, INC. ANY REPRODUCTION IN  
 PART OR AS A WHOLE WITHOUT THE  
 WRITTEN PERMISSION OF FERINCO, INC.  
 IS PROHIBITED.

**TOLERANCES:**  
 .X= Fractional ±  
 .XX= ±.06  
 ANG.= +3°  
 UNLESS OTHERWISE SPECIFIED

Part Weight	0.22 lbs.	Installation Torque	
Min/Max Temp.	-30/140 Degrees F	Conforms to ASTM	
Pressure Tested	4.3 PSI	Clamps used	
Material	Flexible PVC 60 Duro Shore A	Box Quantity	

UNITS:	SIZE:
INCHES	<b>A</b>
3RD ANGLE PROJECTION	
DO NOT SCALE DRAWING	

DESIGNER:	DATE:
D. Brady	8/26/2011
CHECKER:	

SCALE:
not to scale
SHEET 1 OF 1