

INSTALLATION AND MAINTENANCE INSTRUCTIONS

IM-4-105-US

October 2016

Balanced Pressure Thermostatic Air Vent Type VS 204 & 206

Operation

Thermostatic steam air vents sense the temperature difference between steam and non-condensable vapors to operate a valve head. The vent is wide open when cold providing a free access for non-condensibles and air to be removed from the system. These vents are self-adjusting and will work equally well at any pressure up to the maximum operating pressure of the vent. These vents are not recommended for superheat service.

Installation

The air vent should be positioned at a high point of the piping system or equipment or where the air collects. The vent must be piped in a vertical position so only air and steam surround the thermostatic bellows. The discharge can be hot and wet; the outlet should, therefore, be piped to a safe place. An isolation valve should be placed on the inlet side of the vent.

Maintenance

This product can be maintained without disturbing the inlet piping connections. Complete isolation is required before any servicing is performed. The vent must be cooled down before disassembly to prevent over-expansion damage to the bellows.

The air vent should be disassembled periodically for inspection and cleaning of the valve head and seat. Worn or damaged parts should be replaced using a complete element set.

Spare Parts

Cap with Gasket	A
Cap Screws, Set	B
Element Set	C, D, E, F
Element & Lockwasher	E, F
Seat & Gasket	C, D

Torque Req.	Valve Seat	ELE Holder	Cover Screws
VS 204 & 206	45-55 ft/lb	27-31 ft/lb	20-25 ft/lb

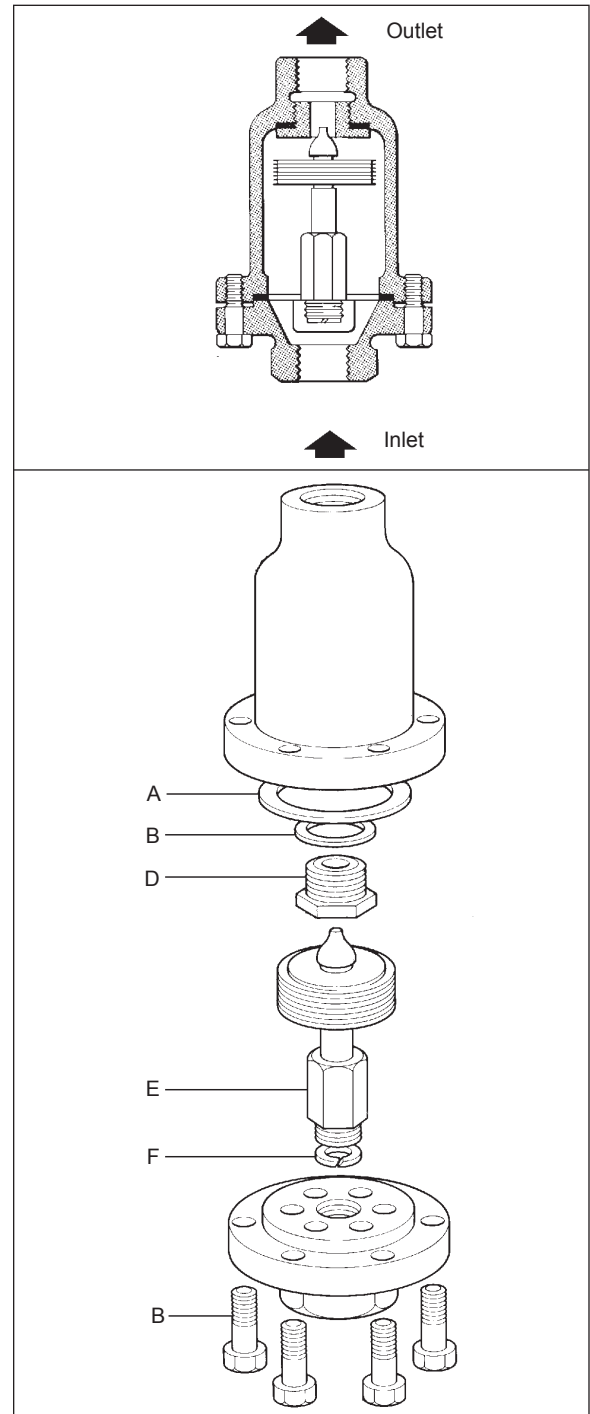

Typical Hook-up for VS Series Air Vents on Various Equipment

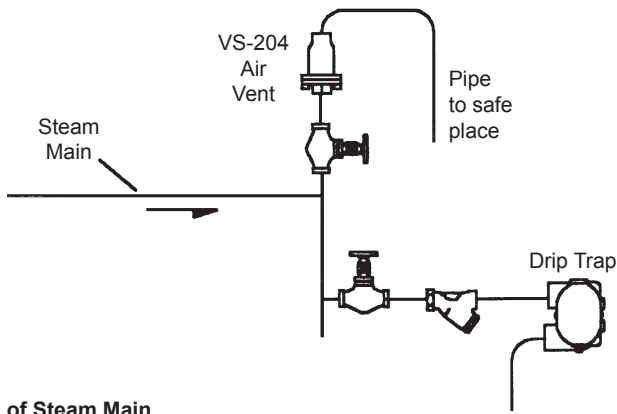

End of Steam Main

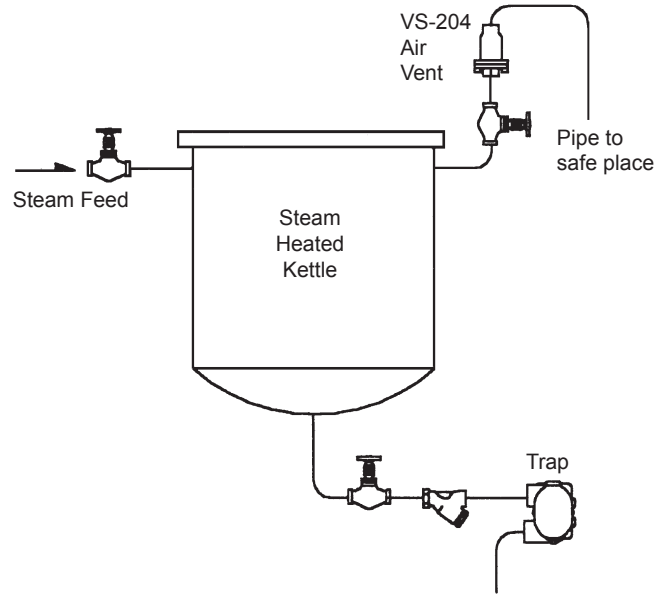

Steam Heated Kettle

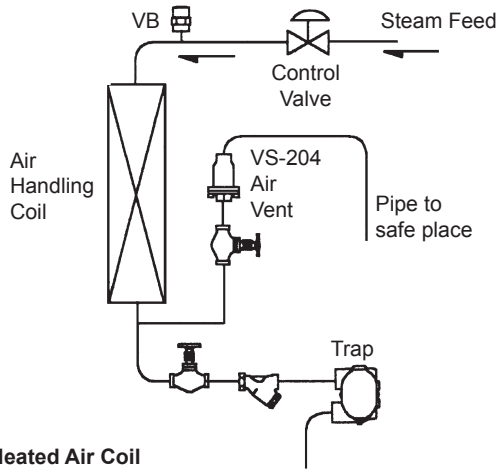

Steam Heated Air Coil

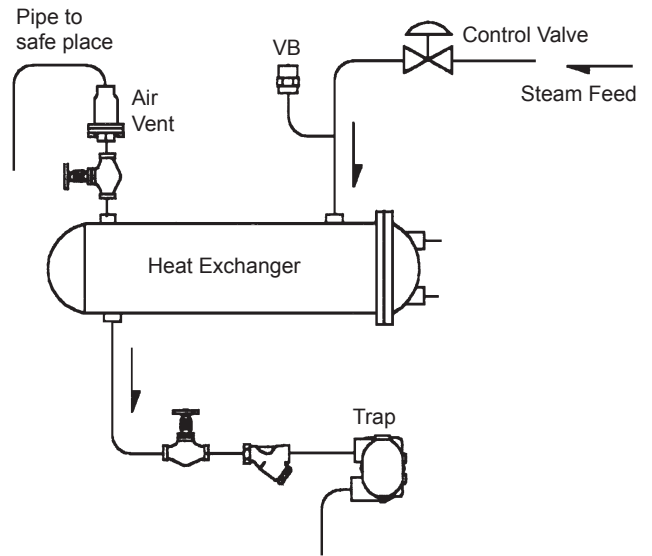

Liquid Heat Exchanger

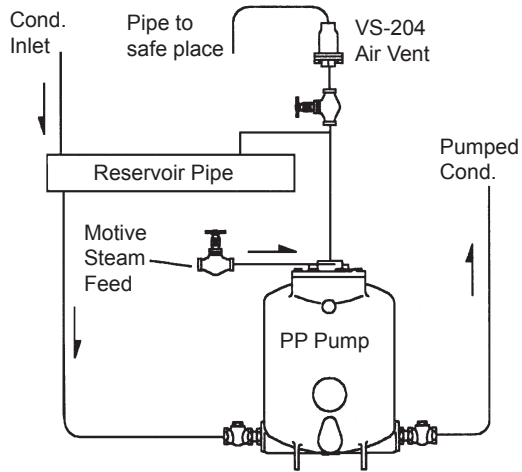

Closed Loop Pump System

Spirax Sarco Applications Engineering Department
Toll Free at: 1-800-883-4411



SPIRAX SARCO, INC. • 1150 NORTHPOINT BLVD. • BLYTHEWOOD, SC 29016
spiraxsarco.com/global/us