

# INSTALLATION INSTRUCTIONS

Read installation instructions first before installing. Check parts to ensure that no damage has occurred during transit and that no parts are missing. Also check the diameter of the pipe and the range marked on the clamp to ensure you have the proper size.

## Style SS1, SS2, SS3 Stainless-Seal Pipe Repair Clamp

**Step 1** • Check the clamp parts to insure that no damage has occurred during transit and that no parts are missing. Thoroughly clean pipe surface that will be covered by the clamp. A suitable gasket lubricant should be used on rough surfaced pipe (Iron and A/C) to assure proper seal.

**Step 2** • Place reference marks on the pipe in line with the crack or hole in the pipe slightly wider than the clamp.

**If using tapped repair clamp**, be sure that the outlet is positioned in the area where the tap is to be done.

**Step 3** • Back off nuts to end of bolts, but **DO NOT REMOVE THEM**.

**SS1:** Separate clamp and wrap it around the pipe.

**SS2 and SS3:** Separate the clamp sections. Center one of the sections over the crack or hole being repaired. If possible, position one of the sections around the pipe so the bolts and receiver lugs are in a convenient place to assemble and tighten.

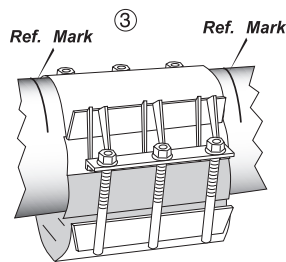

**Note:** If necessary because of flowing water, Steps 3 and 4 can be performed beside the pipe crack or hole. Slide the clamp over the break after the lifter bars have been snapped into place.

**Step 4** • Slide the lifter bar(s) up the receiver lug profile and snap into place over the side bar edge. Make sure the gasket tails are not folded under, but are laying flat around the pipe. Tighten nuts finger tight to allow the centering of the clamp over the crack or hole being repaired (check reference marks).

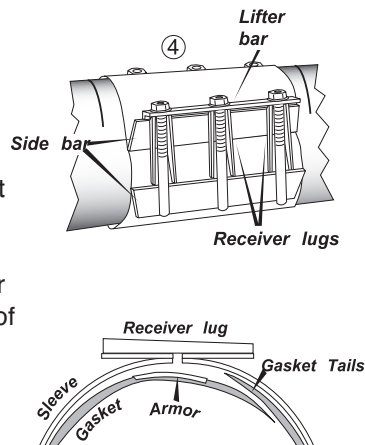

**Step 5** • Tighten all nuts evenly in 20 ft-lbs increments. Start tightening in the center of the clamp, working toward each end. Keep the torque as even as possible between all nuts. It is necessary to re-torque every nut several times (4-8) in order to maintain the proper torque. Start at 20 ft-lbs, then 40 ft-lbs, 60 ft-lbs, and finally 80 ft-lbs, or until the recommended torque has been reached. See table below. Use a wrench with at least a 12" handle.

**Note:** When tightening the nuts of SS2 or SS3 Repair Clamps, be sure to maintain an equal gap between the sidebars.

Nom. Pipe Diameter	Torque
4" and below	30-35 ft-lbs.
6" and above	75-85 ft-lbs.

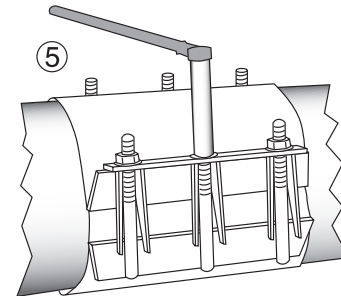

**Note:**  
35 ft-lbs. = 12" wrench w/ 35 lb. force  
75 ft-lbs. = 12" wrench w/ 75 lb. force

For best results, wait at least 10 minutes, then re-tighten.

For sizes 6" and larger, deforming or breaking of plastic lubricating washers and dimpling of the washer plates (lifter bars) is normal and does not affect the performance of the sleeve. In fact, lack of washer deformation indicates inadequate nut tightening.

**If using tapped repair clamp**, pressure test before tapping.

Backfill and compact carefully around clamp and service line.

## Stainless-Seal Pipe Repair Clamp Style SS1, SS2, SS3

### PRECAUTIONS

1. Check diameter of pipe to make sure you are using the correct size clamp.
2. Clean pipe to remove dirt and corrosion from the surface.
3. Place marks on the pipe to reference the leak. Use these marks to assure that the clamp is properly positioned.
4. Make sure no foreign materials stick to the gasket as it is brought around the pipe, nor become lodged between gasket and pipe as nuts are tightened.
5. Avoid loose fitting wrenches, or wrenches too short to achieve proper torque.
6. Keep threads free of foreign material to facilitate tightening.
7. Bolts are often not tightened enough when a torque wrench is not used. Take extra care in this situation to make sure proper tightening occurs.
8. Pressure test for leaks before backfilling.
9. Backfill and compact carefully around clamp.
10. When reinstalling parts with stainless steel hardware there may be a loss in pressure holding ability due to worn or damaged threads during the original installation.

### COMMON INSTALLATION PROBLEMS

1. Bolts are not tightened to the proper torque.
2. Rocks or debris between pipe and gasket.
3. Dirt on threads of bolts or nuts.
4. Repair clamp too small for the size of damage to pipe.
5. Repair clamp not centered over damaged portion of pipe.
6. Repair clamps should not be used as couplings.
7. Gaps between sections are not equal.
8. Gasket overlaps are folded over.
9. Not using proper lubrication.