

PRODUCT SPECIFICATION DRAWING

HOLDRITE® Silencer™ Through-Stud / Suspension Clamp #261 & #262

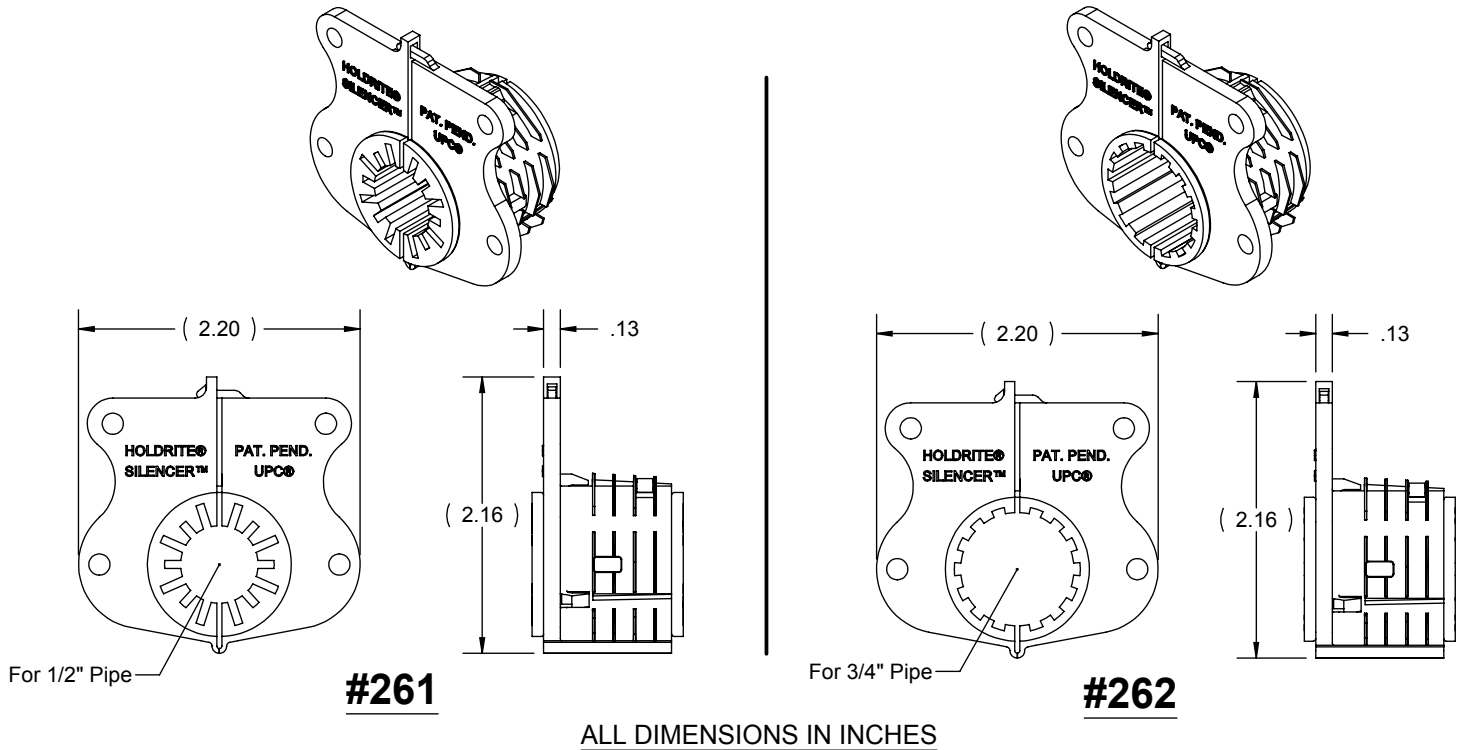

Model #'s 261 and 262 can be used as a suspension hanger, e.g., from a joist or cross-member or a HOLDRITE® Stout Bracket™, or as a through-hole isolator in wood or up to 14 gage metal framing into a 1-11/32" - 1-3/8" hole. As a through-hole isolator, they can also be used with HOLDRITE® #103, #121, and #709 series brackets. These models are used for securing and retaining tubing while providing superior acoustical isolation between the tubing and the supporting structure. Supports 1/2" and 3/4" CTS tube sizes. Supports Copper, PEX, CPVC tubing, conduit, etc. UPC listed.

Product Information:

- Material:
Shell: Polypropylene, blue, FR UL94-V2
Isolators: TPE, natural (off-white), 45 shore A
- Temperature Range: -10°F to 140°F (suspension)
-10°F to 180°F (through-stud)
- Load rating: 25 pounds in suspension mode
- UPC / IPC listed
- IAPMO listed, per standard PS42-96
- Patent Pending



THIS INFORMATION IS PROPRIETARY TO HOLDRITE AND IS SUBJECT TO CHANGE WITHOUT NOTICE. IT MAY NOT BE REPRODUCED IN PART OR WHOLE WITHOUT WRITTEN AUTHORIZATION.



CONVERTING MAKESHIFT METHODS INTO ENGINEERED SOLUTIONSSM
800-321-0316 OR 760-744-6944 / FAX: 760-744-0507 / WWW.HOLDRITE.COM
spec_261_262_RevP

Product Submittal	
Job Name:	
Date:	
Part Number:	Qty:
Architect / Owner:	
Contractor:	
Notes:	