

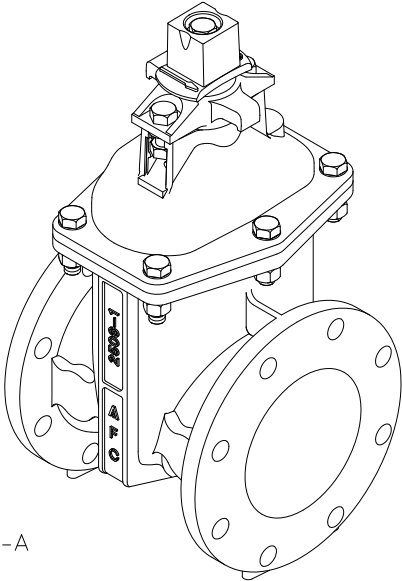

# SERIES 2500 RESILIENT WEDGE GATE VALVE



The **Series 2500 Ductile Iron** Resilient Wedge Gate Valve has a rated working pressure of 250 psig and is designed for use in drinking water, sewage, fire protection systems, and irrigation and backflow control systems.

The **Series 2500** Resilient Wedge Gate Valve can be furnished in configurations that are UL Listed and FM Approved.

## FEATURES AND BENEFITS



### FEATURES

AMERICAN Flow Control's Series 2500 Ductile Iron Resilient Wedge Gate Valves are suitable for use in drinking water, sewage and fire protection systems. The Series 2500 has a rated working pressure of 250 psig and seal with zero leakage. The design employs a clear unobstructed waterway.

### ADVANTAGES WHEN COMPARED TO BUTTERFLY VALVES

- The 2500 has no disc in waterway to restrict flow or to increase pumping costs.
- The clear waterway allows passage of pigging devices.
- Internal parts can be serviced without cutting the valve out of the pipeline.
- The 250 psig rating allows working pressure to be increased above the 150 psig pressure rating found on most butterfly valves.

### ADVANTAGES WHEN COMPARED TO DOUBLE DISC GATE VALVES

- The 2500 closes with zero leakage. No more time consuming testing to determine allowable leakage rate.
- No pocket in bottom of valve to collect sediment or trap debris.
- Lower torque requirements to operate valve.
- 250 psig pressure rating compared to the 200 psig rating found on most double disc gate valves.
- Fusion bonded epoxy coated inside and out.
- Lower total valve weight.

### SERIES 2500 RESILIENT WEDGE GATE VALVE STANDARD FEATURES

- 250 psig rated working pressure.
- Ductile iron body, bonnet, wedge, operating nut and stuffing box.
- Triple O-ring stem seals.
- Thrust washers.
- Fusion bonded epoxy coating.
- 100% bottle tight closure.
- Rubber encapsulated wedge.
- Flat features on valve body allows the valve to stand upright for storage or, during installation.
- Optional geared actuators.
- 2 in.–66 in. valves are Certified to NSF/ANSI Standard 61 and NSF/ANSI 372.

### BENEFITS

#### DUCTILE IRON CONSTRUCTION

The ductile iron body and bonnet provide superior strength and allow a pressure rating of 250 psig. The strength of ductile iron is double that provided by gray iron. This added strength and higher pressure rating is provided in a compact, lighter design.

#### FUSION BONDED EPOXY COATING

The Series 2500 valve is epoxy coated both on the interior as well as the exterior of the valve. The fusion bonded coating is applied after the valve body is shot blasted clean. The coating is applied to all ferrous surfaces so that even the bolt holes and body-to-bonnet flange surfaces are epoxy coated.

#### THRUST WASHERS

Thrust washers are located above and below the stem collar ensuring trouble-free operation of the valve.

#### DUCTILE IRON LIFTING LUGS

The stuffing box is constructed of high strength ductile iron with integral lifting lugs on most sizes. Lifting lugs allow the valve to be lifted safely, without risk of the valve falling or damaging the valve by lifting from the operating nut.

#### TRIPLE O-RING STEM SEALS

This valve features triple O-ring stem seals. Two O-rings are located above the thrust collar and one O-ring is located below the thrust collar. The O-ring directly above and below the stem collar provide a sealed lubrication chamber. This feature assures the ease of operation for long periods of time without the need for constant maintenance required for other designs. The upper O-ring acts as a shield, sealing the stem from dirt and grit that might otherwise enter the stuffing box in buried and sewage service applications.

#### NO FLAT GASKETS

The stuffing box gasket and bonnet gasket are pressure energized rubber O-rings. This assures sealing of the valve components without the need for excessive bolt loading as is required by flat gaskets. The O-ring seals are reusable, which eliminates the need for time consuming cleaning, scrapping and cutting of new gaskets.

#### AVAILABLE IN UL AND FM CONFIGURATIONS

The Series 2500 valve can be furnished in configurations that are UL Listed and Approved by FM Approvals.

Configurations not available as UL/FM:

- NRS with handwheel
- Open right (NRS or OS & Y)
- NRS with gearing
- 2 in. NRS

# SERIES 2500 - STANDARD NRS DIMENSIONS, 2"–24" SIZES

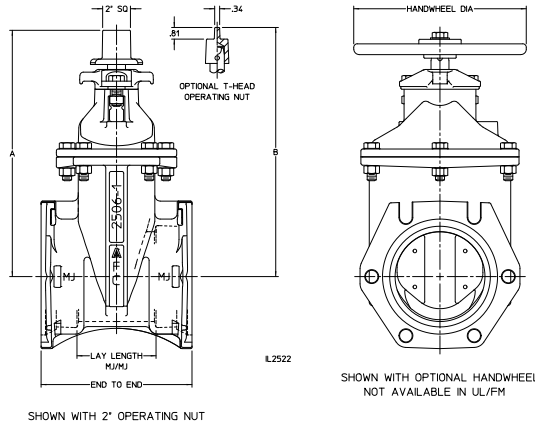

Dimension	Series 2500 / Series 2500-1												
	2"	2-1/2"	3"	4"	6"	8"	10"	12"	14"	16"	18"	20"	24"
A	8.44	11.03	11.84	13.91	17.12	20.47	24.06	27.59	33.25	36.75	39.62	43.25	51.25
B	9.36	12.00	N/A	N/A	N/A	N/A	N/A	N/A	N/A	N/A	N/A	N/A	N/A
C Waterway Diameter	2.06	2.50	3.19	4.25	6.25	8.25	10.25	12.25	14.19	16.19	18.12	20.12	24.12
End to End - MJ/MJ	7.75	N/A	8.62	10.00	10.50	11.50	12.50	13.50	20.50	20.88	23.00	23.50	25.62
Lay Length - MJ/MJ	2.75	N/A	3.62	5.00	5.50	6.50	7.50	8.50	13.50	13.88	16.00	16.50	18.62
End to End - FL/FL (Class 125)	7.00	7.50	8.00	9.00	10.50	11.50	13.00	14.00	15.00	16.00	17.00	18.00	20.00
End to End - FL/FL (Class 250)	N/A	N/A	11.12	12.00	15.88	16.50	18.00	19.75	18.50	21.00	22.00	24.00	26.38
End to End - TY/TY	N/A	N/A	N/A	13.00	15.88	17.50	18.75	19.75	N/A	N/A	N/A	N/A	N/A
End to End - PO/PO (Push-On)	N/A	N/A	N/A	N/A	N/A	N/A	N/A	N/A	22.16	24.66	N/A	N/A	N/A
End to End - FL/MJ (Class 125)	N/A	N/A	8.31	9.50	10.50	12.38	13.62	14.38	17.75	18.44	20.00	20.75	22.81
End to End - FL/TY (Class 125)	N/A	N/A	N/A	11.00	13.19	14.50	15.88	16.88	N/A	N/A	N/A	N/A	N/A
End to End - PVC/PVC	10.75	11.12	11.38	13.00	15.88	17.50	N/A	N/A	N/A	N/A	N/A	N/A	N/A
End to End - Threaded	5.0	7.38	7.38	N/A	N/A	N/A	N/A	N/A	N/A	N/A	N/A	N/A	N/A
End to End - FX/FX (Flex-Ring®)	N/A	N/A	N/A	N/A	17.00	N/A	N/A	N/A	N/A	28.50	N/A	31.50	34.50
Lay Length - FX/FX (Flex-Ring®)	N/A	N/A	N/A	N/A	5.50	N/A	N/A	N/A	N/A	13.62	N/A	15.12	16.62
End to End - AA/AA (ALPHA™)	N/A	N/A	N/A	11.34	12.81	16.22	17.34	18.96	N/A	N/A	N/A	N/A	N/A
Lay Length - AA/AA (ALPHA™)	N/A	N/A	N/A	4.24	5.32	6.37	7.15	8.31	N/A	N/A	N/A	N/A	N/A
End to End - AX/AX (ALPHA™ XL)	N/A	N/A	N/A	12.64	13.40	17.38	18.30	20.27	N/A	N/A	N/A	N/A	N/A
Lay Length - AX/AX (ALPHA™ XL)	N/A	N/A	N/A	4.24	5.32	6.37	7.15	8.31	N/A	N/A	N/A	N/A	N/A
End to End - FL(Class 125)/AA(ALPHA™)	N/A	N/A	N/A	10.82	11.95	14.44	15.65	17.14	N/A	N/A	N/A	N/A	N/A
Lay Length - FL(Class 125)/AA(ALPHA™)	N/A	N/A	N/A	6.62	7.91	8.93	10.07	11.15	N/A	N/A	N/A	N/A	N/A
End to End - MJ/AA (ALPHA™)	N/A	N/A	N/A	N/A	11.95	N/A	N/A	N/A	N/A	N/A	N/A	N/A	N/A
Lay Length - MJ/AA (ALPHA™)	N/A	N/A	N/A	N/A	5.41	N/A	N/A	N/A	N/A	N/A	N/A	N/A	N/A
Handwheel Diameter	7.00	8.00	8.00	10.00	12.00	14.00	16.00	16.00	20.00	20.00	20.00	28.00	28.00
No. of Turns to Open	9	11	13	14	20	26	32	38	44	50	56	62	76

**NOTES:**

1. 3 in.–54 in. valves meet or exceed requirements of ANSI/AWWA C515.
2. 2 in.–24 in. valves may be ordered in configurations which are UL Listed and FM Approved.
3. 2 in.–48 in. valves have 250 psig AWWA rated working pressure.
4. 2 in.–24 in. valves in Listed and Approved configurations have 250 psig UL and FM rated working pressure.
5. Fusion bonded epoxy coating meets or exceeds requirements of ANSI/AWWA C550.
6. Bolt patterns of Class 125 flanged ends are in accordance with ANSI/AWWA C110/A21.10 (ASME B16.1 Class 125).
7. Threaded ends are in accordance with ASME B16.4, Class 125.
8. Mechanical joint ends are in accordance with ANSI/AWWA C111/A21.11.
9. Push-on ends are in accordance with ANSI/AWWA C111/A21.11 for use on ductile iron pipe sizes. Valves are furnished with TYTON® (TY) ends.
10. TYTON® is a registered trademark of United States Pipe and Foundry Co., LLC.
11. PVC ends are suitable for use on steel (IPS) sizes of PVC or steel pipe.
12. 2 in.–66 in. valves are Certified to NSF/ANSI Standard 61 and NSF/ANSI 372.
13. Valves for use with raw sewage should be orientated with valve stems vertical.
14. ALPHA™ is a trademark of Romac Industries, Inc. (U.S. Patent 8,894,100)
15. 6" Flex-Ring® and MJ x ALPHA™ valves for use on hydrant leads.

# SERIES 2500 - NRS WITH ENCLOSED MITER GEARING DIMENSIONS, 3" - 12" SIZES

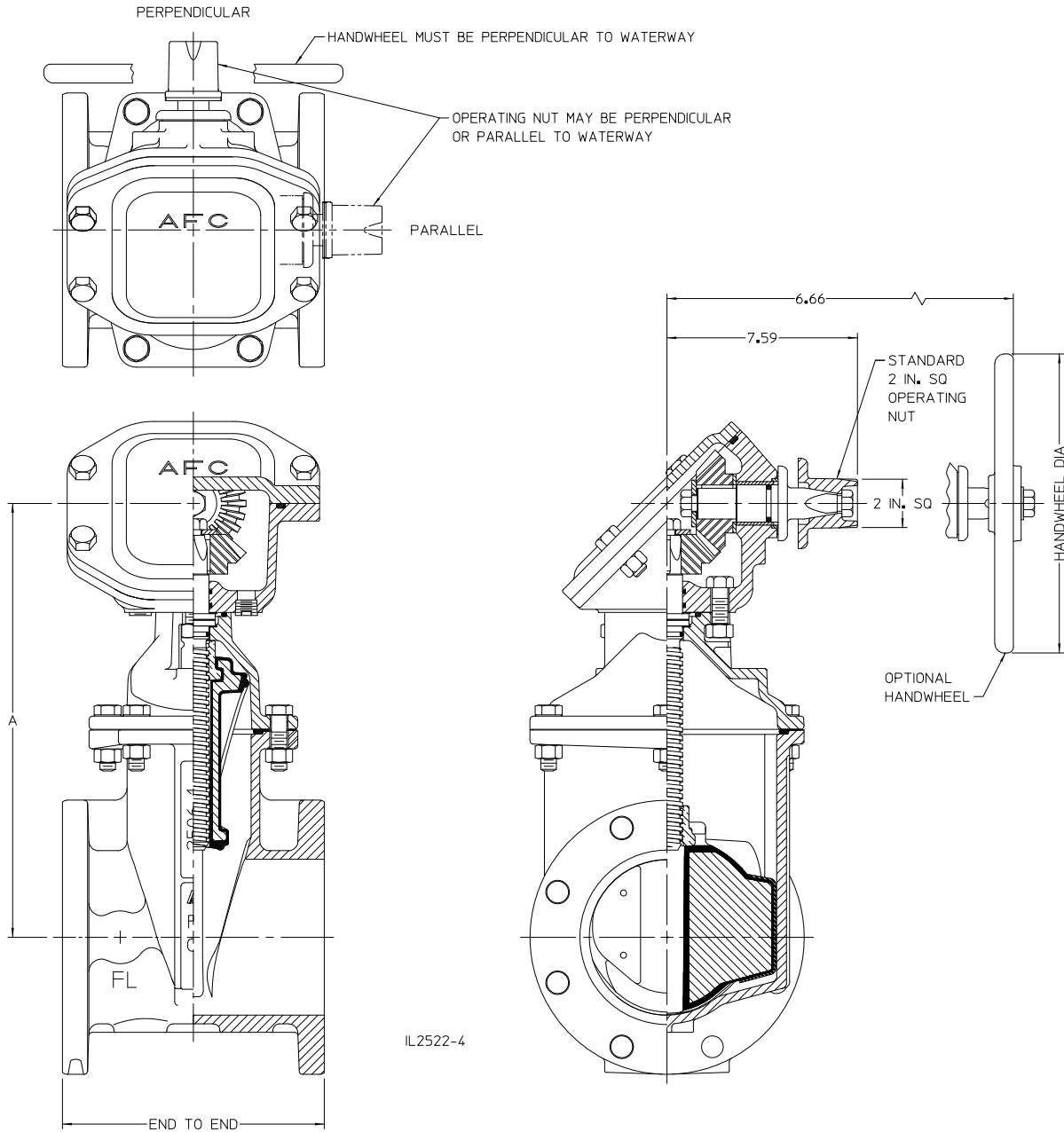

Model	Valve Size	Dimension		
		A	End to End Flange x Flange	Handwheel Diameter
Series 2500	3"	12.72	8.00	8.00
Series 2500-1	4"	14.16	9.00	10.00
	6"	17.03	10.50	12.00
	8"	20.59	11.50	14.00
	10"	24.22	13.00	14.00
	12"	27.66	14.00	14.00

# SERIES 2500 - NRS WITH BEVEL GEARING DIMENSIONS, 14"-66" SIZES

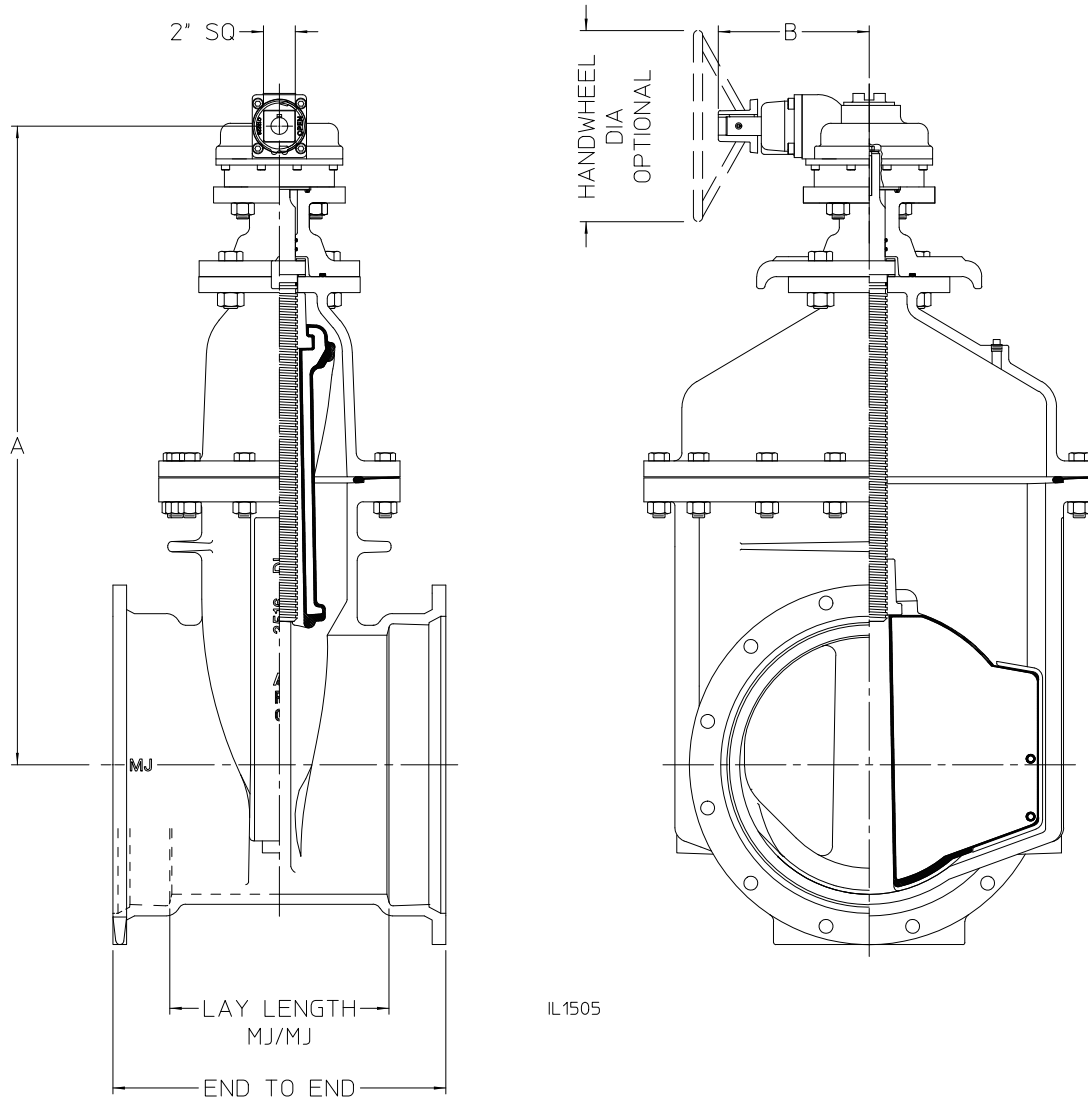

IL1505

Dimension	Valve Size											
	Series 2500											
	14"	16"	18"	20"	24"	30"	36"	42"	48"	54"	60"	66"
A	35.19	39.75	43.00	44.44	52.62	62.62	74.38	86.28	96.00	96.00	118.00	118.00
B	9.50	9.50	9.50	10.38	10.38	13.56	15.38	19.19	19.19	19.19	19.19	19.19
C Waterway Diameter	14.19	16.19	18.12	20.12	24.12	30.22	36.19	42.38	48.38	48.38	60.50	60.50
End to End - MJ/MJ	20.50	20.88	23.00	23.50	25.62	33.75	37.50	46.75	45.00	N/A	N/A	N/A
Lay Length - MJ/MJ	13.50	13.88	16.00	16.50	18.62	25.75	29.50	38.75	37.00	N/A	N/A	N/A
End to End - FL/FL (Class 125)	15.00	16.00	17.00	18.00	20.00	26.00	30.00	38.00	43.00	48.00	53.00	58.00
End to End - FL/FL (Class 250)	18.50	21.00	22.00	24.00	26.38	32.00	37.00	40.00	46.25	N/A	N/A	N/A
End to End - PO/PO (Push-On)	22.16	24.66	N/A	N/A	N/A	N/A	N/A	N/A	N/A	N/A	N/A	N/A
End to End - FL/MJ (Class 125)	17.75	18.44	20.00	20.75	22.81	29.88	22.75	42.38	44.00	N/A	N/A	N/A
End to End - FX/FX (Flex-Ring®)	N/A	28.50	N/A	31.50	34.50	41.00	44.50	53.50	62.00	N/A	71.00	N/A
Lay Length - FX/FX (Flex-Ring®)	N/A	13.62	N/A	15.12	16.62	21.75	25.19	31.75	37.25	N/A	44.88	N/A
Handwheel Diameter	12.00	12.00	12.00	20.00	20.00	20.00	20.00	32.00	32.00	32.00	36.00	36.00
No. of Turns to Open	88	100	112	186	228	379	448	694	789	789	984	984

# SERIES 2500 - NRS WITH SPUR GEARING DIMENSIONS, 14" - 66" SIZES

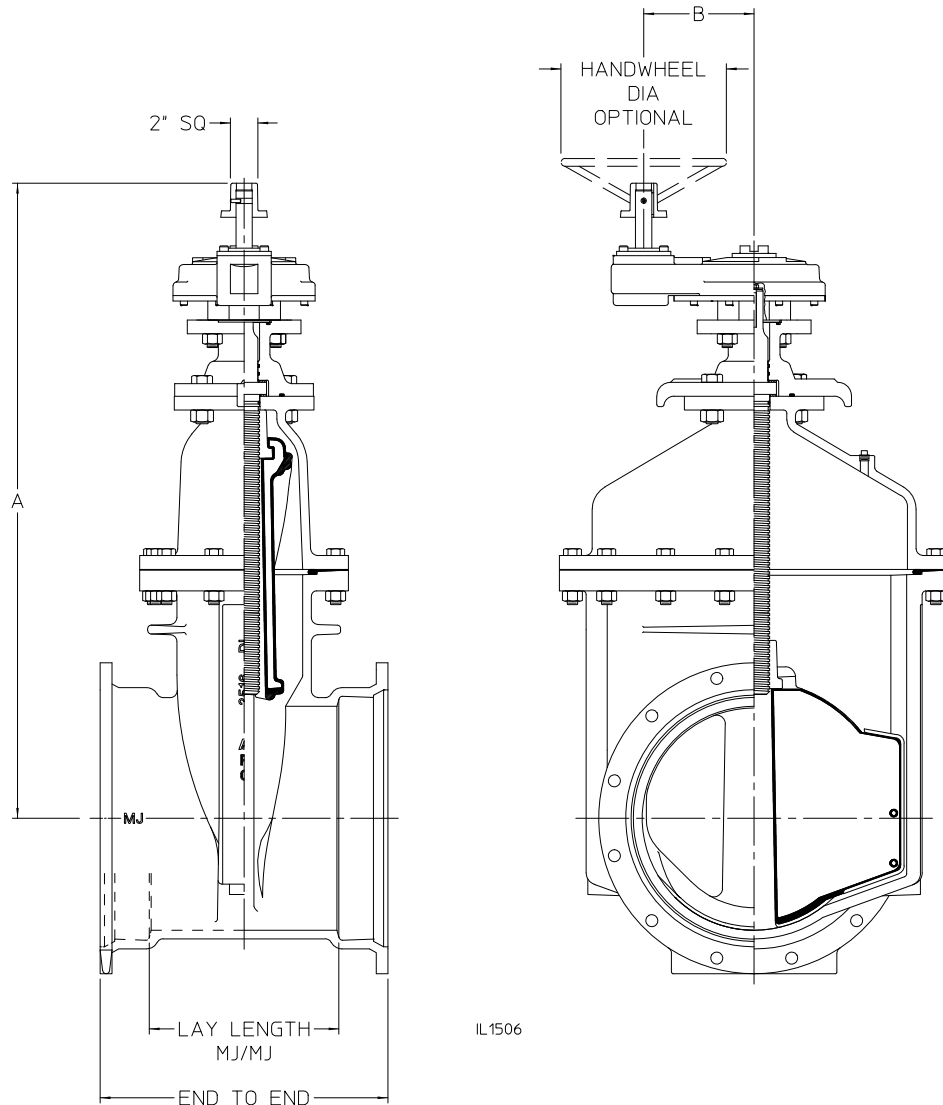

IL1506

Dimension	Valve Size											
	Series 2500											
	14"	16"	18"	20"	24"	30"	36"	42"	48"	54"	60"	66"
A	42.00	45.50	51.38	49.50	57.63	71.00	83.00	98.75	108.50	108.50	128.31	128.31
B	8.03	8.03	8.03	12.00	12.00	13.12	14.00	16.12	16.12	16.12	16.00	16.00
C Waterway Diameter	14.19	16.19	18.12	20.12	24.12	30.22	36.19	42.38	48.38	48.38	60.50	60.50
End to End - MJ/MJ	20.50	20.88	23.00	23.50	25.62	33.75	37.50	46.75	45.00	N/A	N/A	N/A
Lay Length - MJ/MJ	13.50	13.88	16.00	16.50	18.62	25.75	29.50	38.75	37.00	N/A	N/A	N/A
End to End - FL/FL (Class 125)	15.00	16.00	17.00	18.00	20.00	26.00	30.00	38.00	43.00	48.00	53.00	58.00
End to End - FL/FL (Class 250)	18.50	21.00	22.00	24.00	26.38	32.00	37.00	40.00	46.25	N/A	N/A	N/A
End to End - PO/PO (Push-On)	22.16	24.66	N/A	N/A	N/A	N/A	N/A	N/A	N/A	N/A	N/A	N/A
End to End - FL/MJ (Class 125)	17.75	18.44	20.00	20.75	22.81	29.88	22.75	42.38	44.00	N/A	N/A	N/A
End to End - FX/FX (Flex-Ring®)	N/A	28.50	N/A	31.50	34.50	41.00	44.50	53.50	62.00	N/A	71.00	N/A
Lay Length - FX/FX (Flex-Ring®)	N/A	13.62	N/A	15.12	16.62	21.75	25.19	31.75	37.25	N/A	44.88	N/A
Handwheel Diameter	12.00	12.00	12.00	20.00	20.00	20.00	20.00	32.00	32.00	32.00	36.00	36.00
No. of Turns to Open	88	100	112	186	228	379	448	694	798	798	984	984

## SERIES 2500 - OS & Y DIMENSIONS, 2" - 24" SIZES

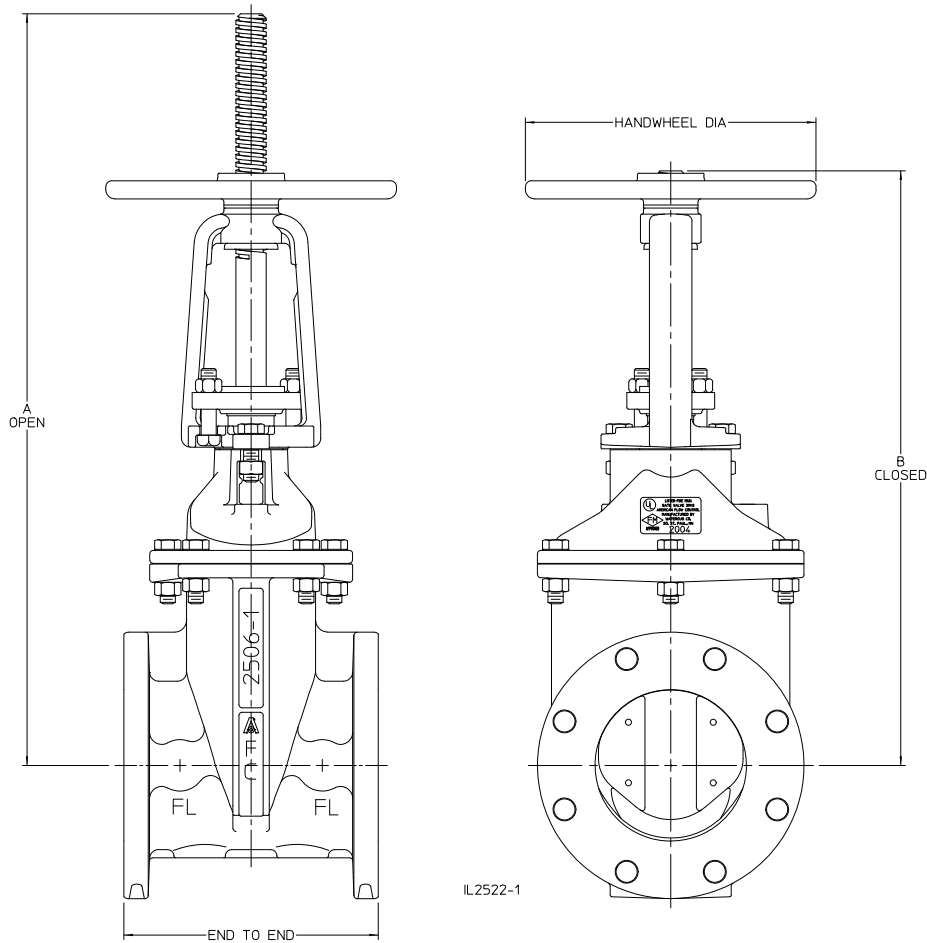

Dimensions	Valve Size												
	Series 2500 / Series 2500-1												
	2"	2-1/2"	3"	4"	6"	8"	10"	12"	14"	16"	18"	20"	24"
A (Valve Open) +/- 1/4	13.28	16.78	18.12	23.47	30.97	38.16	48.41	53.66	66.13	72.00	81.25	87.50	105.25
B (Valve Closed) +/- 1/4	11.06	14.12	14.94	19.12	24.59	29.91	38.16	41.78	51.75	55.25	62.63	66.81	79.88
Handwheel Diameter	7.00	8.00	8.00	10.00	12.00	14.00	16.00	16.00	20.00	20.00	20.00	28.00	28.00
End to End - FL/FL (Class 125)	7.00	7.50	8.00	9.00	10.50	11.50	13.00	14.00	15.00	16.00	17.00	18.00	20.00
No. of Turns to Open	9	11	13	14	20	25	31	38	44	50	56	62	76
End to End - FL/FL (Class 250)	N/A	N/A	11.12	12.00	15.88	16.50	18.00	19.75	18.50	21.00	22.00	24.00	26.38

### NOTES:

1. Valves meet or exceed requirements of ANSI/AWWA C515 in applicable sizes.
2. 2 in.–18 in. sizes may be ordered in configurations that are UL Listed and Approved by FM Approvals.
3. 20 in.–24 in. sizes available in configurations that are UL Listed.
4. 250 psig rated working pressure.
5. Fusion bonded epoxy coating meets or exceeds requirements of ANSI/AWWA C550.
6. Bolt patterns of Class 125 flanged ends are in accordance with ANSI/AWWA C110/A21.10 (ASME B16.1 Class 125).
7. Class 250 flanged ends are in accordance with ASME B16.1, Class 250 for cast iron flanges.
8. 2 in.–24 in. valves are Certified to NSF/ANSI Standard 61 and NSF/ANSI 372.

# SERIES 2500 - OPTIONAL END CONNECTIONS, ALL SIZES

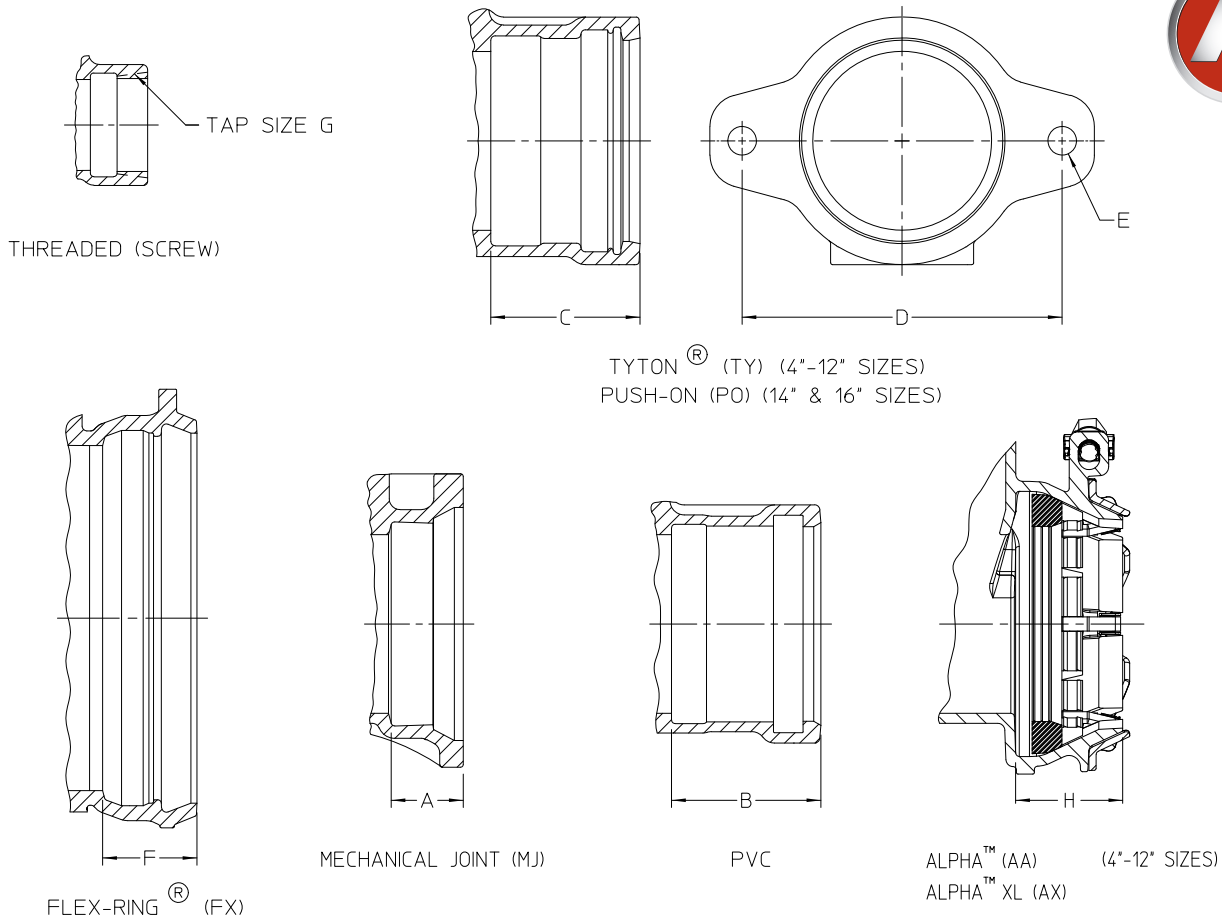

IL2522-5

Dimension	Valve Size																			
	Series 2500 / Series 2500-1																			
	2"	2-1/2"	3"	4"	6"	8"	10"	12"	14"	16"	18"	20"	24"	30"	36"	42"	48"	54"	60"	66"
A (MJ)	2.50	N/A	2.50	2.50	2.50	2.50	2.50	2.50	3.50	3.50	3.50	3.50	3.50	4.00	4.00	4.00	4.00	N/A	N/A	N/A
B (PVC)	1.06	4.00	4.00	4.00	5.22	5.50	N/A	N/A	N/A	N/A	N/A	N/A	N/A	N/A	N/A	N/A	N/A	N/A	N/A	N/A
C (PO)	N/A	N/A	N/A	N/A	N/A	N/A	N/A	N/A	5.62	5.62	N/A	N/A	N/A	N/A	N/A	N/A	N/A	N/A	N/A	N/A
C (TY)	N/A	N/A	N/A	4.00	5.22	5.50	5.62	5.62	N/A	N/A	N/A	N/A	N/A	N/A	N/A	N/A	N/A	N/A	N/A	N/A
D (TY)	N/A	N/A	N/A	9.00	11.19	13.50	15.88	18.00	N/A	N/A	N/A	N/A	N/A	N/A	N/A	N/A	N/A	N/A	N/A	N/A
E DIA. (TY)	N/A	N/A	N/A	1.00	1.00	1.00	1.31	1.31	1.31	N/A	N/A	N/A	N/A	N/A	N/A	N/A	N/A	N/A	N/A	N/A
F (FX)	N/A	N/A	N/A	N/A	5.75	N/A	N/A	N/A	N/A	7.44	N/A	8.19	8.94	9.62	9.66	10.88	12.38	N/A	13.06	N/A
G (Threaded)	2" NPT	2-1/2" NPT	3" NPT	N/A	N/A	N/A	N/A	N/A	N/A	N/A	N/A	N/A	N/A	N/A	N/A	N/A	N/A	N/A	N/A	N/A
H (AA) ALPHA <sup>™</sup>	N/A	N/A	N/A	3.55	3.74	4.92	5.09	5.32	N/A	N/A	N/A	N/A	N/A	N/A	N/A	N/A	N/A	N/A	N/A	N/A
H (AX) ALPHA XL <sup>™</sup>	N/A	N/A	N/A	4.20	4.04	5.50	5.57	5.98	N/A	N/A	N/A	N/A	N/A	N/A	N/A	N/A	N/A	N/A	N/A	N/A
Class 125 Flange	X	X	X	X	X	X	X	X	X	X	X	X	X	X	X	X	X	X	X	X
Class 250 Flange	N/A	N/A	X	X	X	X	X	X	X	X	X	X	X	X	X	X	X	N/A	N/A	N/A

"X" denotes Class 125 and Class 250 flange ends are available for sizes indicated.

**NOTE:**

- Class 125 flange end dimensions and Class 250 flange end dimensions are shown on separate pages. See Class 125 flange dimensions on page 3A-10 and Class 250 flange dimensions on page 3A-11.
- Push-on ends are in accordance with ANSI/AWWA C111/A21.11 for use on ductile iron pipe sizes. Valves are furnished with TYTON<sup>®</sup> (TY) ends. TYTON<sup>®</sup> is a registered trademark of United States Pipe and Foundry Co., LLC.
- ALPHA<sup>™</sup> is a trademark of Romac Industries, Inc. (U.S. Patent 8,894,100)



## SERIES 2500 - CLASS 125 FLANGE DIMENSIONS

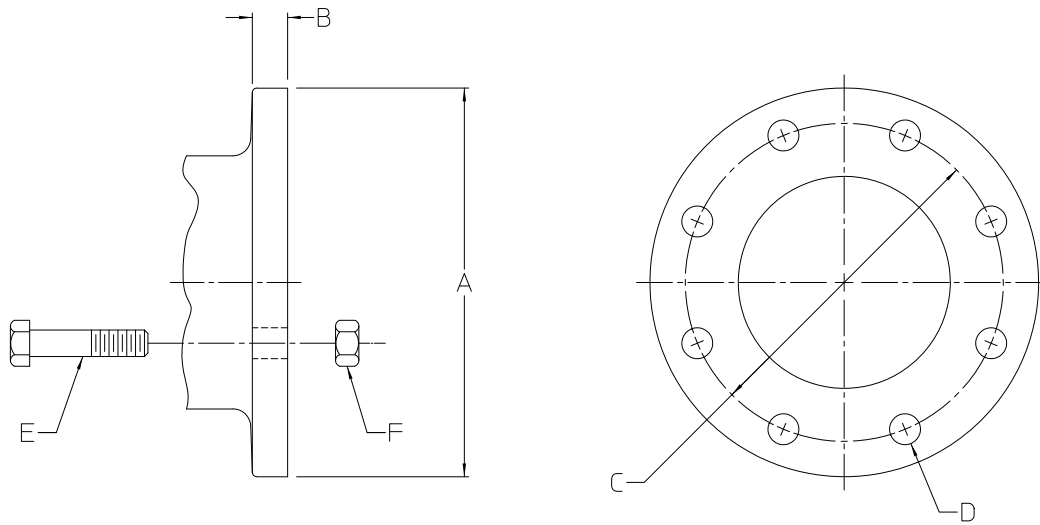

IL1451

Model	Valve Size	A	B	C	D		E	F
		Diameter of Flange	Flange Thickness	Bolt Circle Diameter	Bolt Holes		Bolt Size See Note 2	No. of Hex Nuts Required
					No.	Size		
Series 2500 Series 2500-1	2"	6.00	.62	4.75	4	.75	5/8-11 x 2-1/2	4
	2-1/2"	7.00	.69	5.50	4	.75	5/8-11 x 2-1/2	4
	3"	7.50	.75 ±.12	6.00	4	.75	5/8-11 x 2-1/2	4
	4"	9.00	.94 ±.12	7.50	8	.75	5/8-11 x 3	8
	6"	11.00	1.00 ±.12	9.50	8	.88	3/4-10 x 3-1/2	8
	8"	13.50	1.12 ±.12	11.75	8	.88	3/4-10 x 3-1/2	8
	10"	16.00	1.19 ±.12	14.25	12	1.00	7/8-9 x 4	12
	12"	19.00	1.25 ±.12	17.00	12	1.00	7/8-9 x 4	12
	14"	21.00	1.38 ±.19	18.75	12	1.12	1"-8 x 4-1/2	12
	16"	23.50	1.44 ±.19	21.25	16	1.12	1"-8 x 4-1/2	16
	18"	25.00	1.56 ±.19	22.75	16	1.25	1-1/8-7 x 5	16
	20"	27.50	1.69 ±.19	25.00	20	1.25	1-1/8-7 x 5	20
	24"	32.00	1.88 ±.19	29.50	20	1.38	1-1/4-7 x 5-1/2	20
	30"	38.75	2.12 ±.25	36.00	28	1.38	1-1/4-7 x 6-1/2	28
	36"	46.00	2.38 ±.25	42.75	32	1.62	1-1/2-6 x 7	32
	42"	53.00	2.62 ±.25	49.50	36	1.62	1-1/2-6 x 7-1/2	36
	48"	59.50	2.75 ±.25	56.00	44	1.62	1-1/2-6 x 8	44
	54"	66.25	3.00 ±.25	62.75	44	2.00	1-3/4-5 x 8-1/2	44
60"	73.00	3.12 ±.25	69.25	52	2.00	1-3/4-5 x 9	52	
66"	80.00	3.38 ±.25	76.00	52	2.00	1-3/4-5 x 9-1/2	52	

**NOTES:**

1. Bolt patterns of Class 125 flanged ends are in accordance with ANSI/AWWA C110/A21.10(ASME B16.1 Class 125) Flange thickness tolerances shown are per ANSI/AWWA C110/A21.10.
2. Bolt lengths shown are for standard cast iron flange thicknesses with through holes. Steel or ductile iron flanges with reduced thickness or valves or fittings with tapped holes may require shorter bolts.

## SERIES 2500 - CLASS 250 FLANGE DIMENSIONS

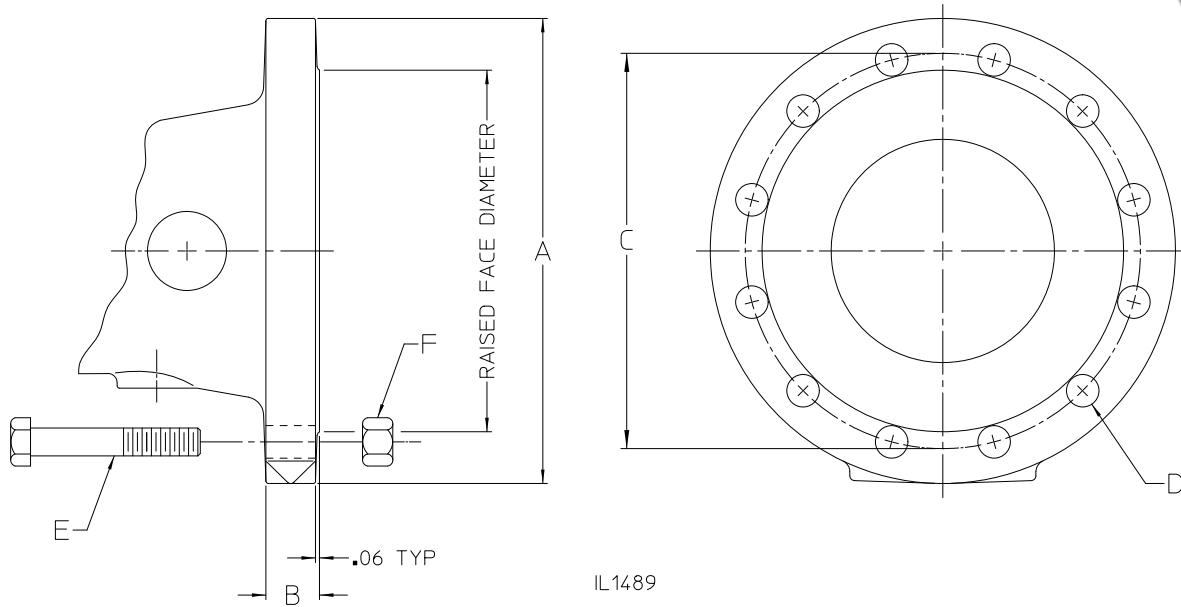

Model	Valve Size	A	B	C	D		E	F	Raised Face Dia.
		Diameter of Flange	Flange Thickness	Bolt Circle Diameter	Bolt Holes		Bolt Size See Note 2	No. of Hex Nuts Required	
					No.	Size			
Series 2500	3"	8.25	1.12	6.62	8	.88	3/4-10 x 3-1/2	8	5.69
Series 2500-1	4"	10.00	1.25	7.88	8	.88	3/4-10 x 4	8	6.94
	6"	12.50	1.44	10.62	12	.88	3/4-10 x 4	12	9.69
	8"	15.00	1.62	13.00	12	1.00	7/8-9 x 4-1/2	12	11.94
	10"	17.50	1.88	15.25	16	1.12	1"-8 x 5-1/2	16	14.06
	12"	20.50	2.00	17.75	16	1.25	1-1/8-7 x 5-1/2	16	16.44
Series 2500	14"	23.00	2.12	20.25	20	1.25	1-1/8-7 x 6	20	18.94
	16"	25.50	2.25	22.50	20	1.38	1-1/4-7 x 6-1/2	20	21.06
	18"	28.00	2.38	24.75	24	1.38	1-1/4-7 x 6-1/2	24	23.31
	20"	30.50	2.50	27.00	24	1.38	1-1/4-7 x 7	24	25.56
	24"	36.00	2.75	32.00	24	1.62	1-1/2-7 x 7-1/2	24	30.31
	30"	43.00	3.00	39.25	28	2.00	1-3/4 x 8-1/2	28	37.19
	36"	50.00	3.38	46.00	32	2.25	2-4-1/2 x 9-1/2	32	43.69
	42"	57.00	3.69	52.75	36	2.25	2-4-1/2 x 10	36	50.44
	48"	65.00	4.00	60.75	40	2.25	2-4-1/2 x 11	40	58.44
	54"	Not Available with Class 250 Raised Face Flanged Ends							
	60"								
66"									

**NOTES:**

1. Flange dimensions shown are per ASME B16.1, Class 250 for cast iron flanges.
2. Bolt lengths shown are for standard cast iron flange thicknesses with thru holes. Steel or ductile iron flanges with reduced thickness or valves or fittings with tapped holes may require shorter bolts.

**SERIES 2500 - OPTIONAL TAPS ON CLASS 125 & CLASS 250  
FLANGE X FLANGE BODIES**

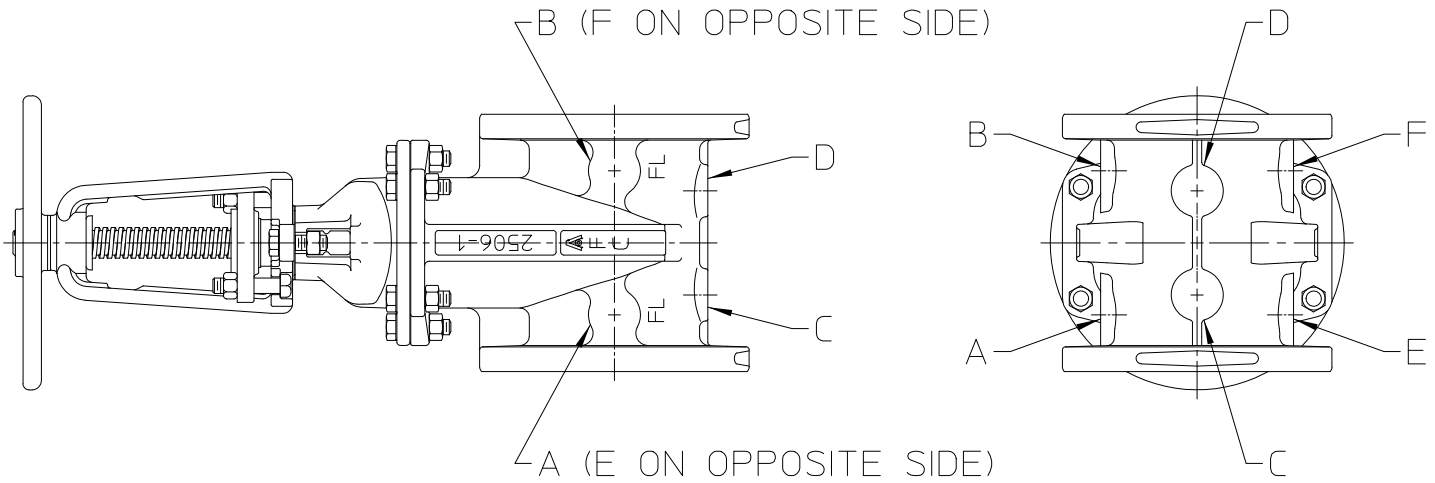

LOCATION OF POSSIBLE TAPS  
ON FLANGE X FLANGE VALVES

IL2522-6

Model	Valve Size	Available Tap Sizes for Boss Locations A, B, C, D, E & F
Series 2500 Series 2500-1	2"	1/2 NPT
	2-1/2"	1/2, 3/4 NPT
	3"	1/2, 3/4 NPT
	4"	1/2, 3/4, 1" NPT
	6"	1/2, 3/4, 1" NPT
	8"	1/2, 3/4, 1" NPT
	10"	1/2, 3/4, 1" NPT
	12"	1/2, 3/4, 1" NPT

**NOTES:**

1. Valve body tap locations are in accordance with MSS SP-45.
2. Taps are available on any valve with flanged ends, whether it is an NRS or OS&Y valve.

# SERIES 2500 - MECHANICAL JOINT ACCESSORIES

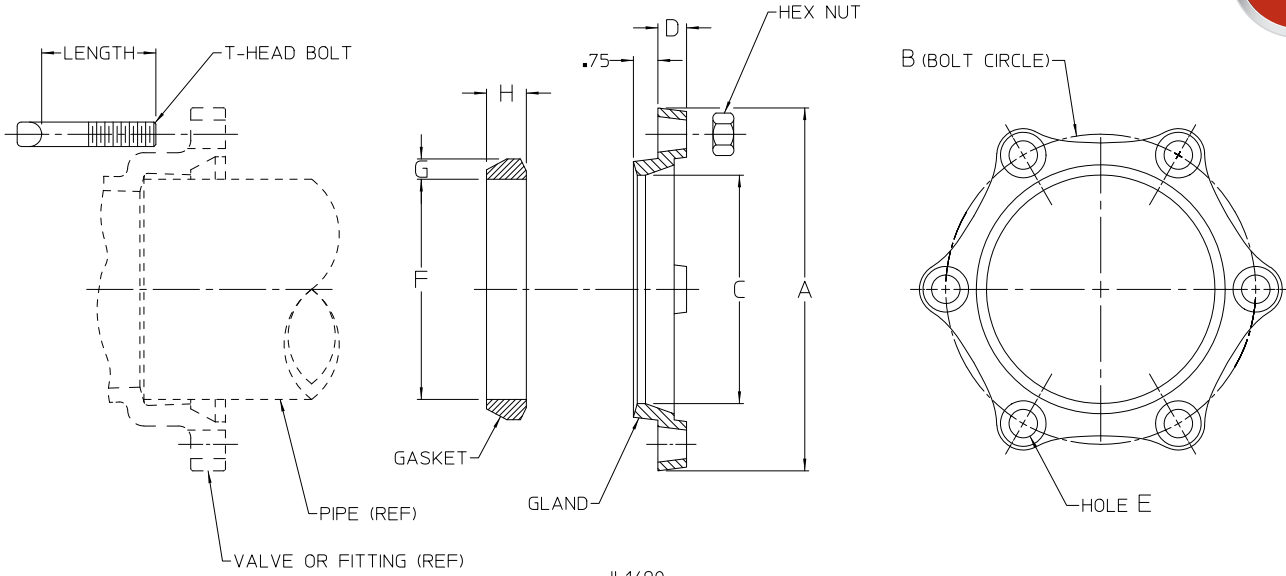

Model	Pipe or Valve Size	Gland						Gasket						T-Head Bolt			
		A Dia.	B Dia.	C Diameter		D	E		F Dia.		G		H		Qty.	Size	Length
				Std. Gland	Pit-Cast Gland		Qty.	Size	Standard Gasket	Transition Gasket	Standard Gasket	Transition Gasket	Standard Gasket	Transition Gasket			
Series 2500	2"	6.25	4.75	2.61	N/A	.62	2	.75	2.48	2.33	.48	.56	1.05	1.11	2	5/8-11	3"
	3"	7.69	6.19	4.06	N/A	.62	4	.75	3.86	3.45	.48	.70	1.05	1.11	4	5/8-11	3"
	4"	9.12	7.50	4.90	5.13	.75	4	.88	4.68	4.43	.62	.77	1.22	1.26	4	3/4-10	3-1/2"
	6"	11.12	9.50	7.00	7.24	.88	6	.88	6.73	6.53	.62	.76	1.22	1.25	6	3/4-10	3-1/2"
	8"	13.37	11.75	9.15	9.46	1.00	6	.88	8.85	8.50	.62	.82	1.22	1.27	6	3/4-10	4"
	10"	15.62	14.00	11.20	11.53	1.00	8	.88	10.87	10.59	.62	.79	1.22	1.26	8	3/4-10	4"
Series 2500-1	12"	17.88	16.25	13.30	13.63	1.00	8	.88	12.95	12.56	.62	.84	1.22	1.28	8	3/4-10	4"
	14"	20.25	18.75	15.44	N/A	1.25	10	.88	14.99	N/A	.62	N/A	1.22	N/A	10	3/4-10	4-1/2"
	16"	22.50	21.00	17.54	N/A	1.31	12	.88	17.07	N/A	.62	N/A	1.22	N/A	12	3/4-10	4-1/2"
	18"	24.75	23.25	19.64	N/A	1.38	12	.88	19.13	N/A	.62	N/A	1.22	N/A	12	3/4-10	4-1/2"
	20"	27.00	25.50	21.74	N/A	1.44	14	.88	21.20	N/A	.62	N/A	1.22	N/A	14	3/4-10	4-1/2"
	24"	31.50	30.00	25.94	N/A	1.56	16	.88	25.34	N/A	.62	N/A	1.22	N/A	16	3/4-10	5"
	30"	39.12	36.88	32.17	N/A	2.00	20	1.12	31.47	N/A	.73	N/A	1.54	N/A	20	1"-8	6"
	36"	46.00	43.75	38.47	N/A	2.00	24	1.12	37.67	N/A	.73	N/A	1.54	N/A	24	1"-8	6"
42"	53.12	50.62	44.67	N/A	2.00	28	1.38	43.78	N/A	.73	N/A	1.54	N/A	28	1-1/4-7	6-1/2"	
48"	60.00	57.50	50.97	N/A	2.00	32	1.38	49.98	N/A	.73	N/A	1.54	N/A	32	1-1/4-7	6-1/2"	

## NOTES:

1. Dimensions shown for standard glands and gaskets in 2 in. - 48 in. sizes are in accordance with ANSI/AWWA C111/A21.11 and ANSI/AWWA C153/A21.53.
2. Dimensions shown are nominal.
3. T-head bolts and nuts are high-strength, low-alloy steel.
4. Glands are ductile iron.



## SERIES 2500 - STANDARD NRS PARTS LIST, 2" SIZE

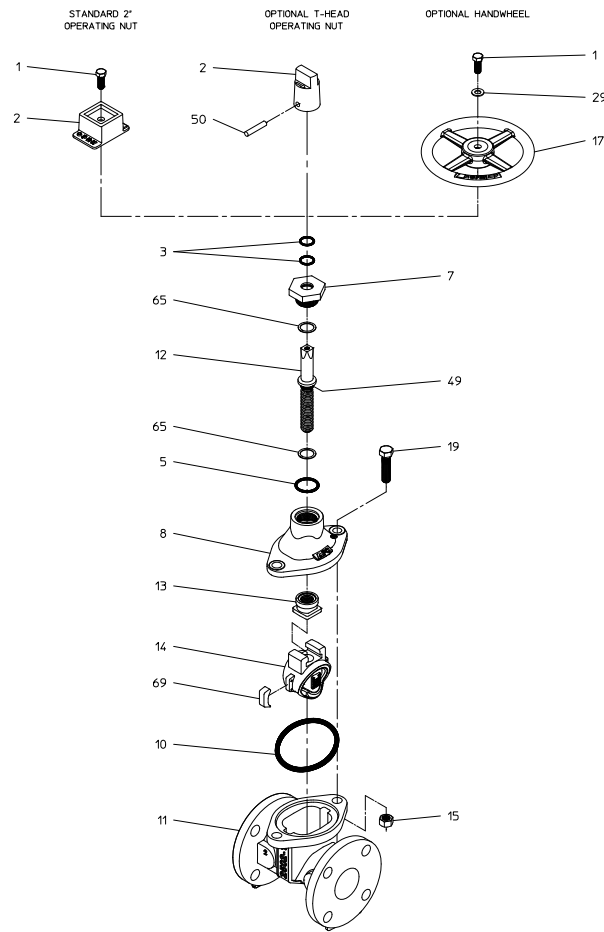

L482

Ref No.	Description	Material	Qty. Series 2500-1
1	Hex Head Bolt, 3/8-16 x 1"	304 Stainless Steel	1
2	Operating Nut, 2" Square	Ductile Iron	1
3	O-ring	Rubber	2
5	Stuffing Box Gasket	Rubber O-ring	1
7	Stuffing Box	Brass	1
8	Bonnet	Ductile Iron	1
10	Bonnet Gasket	Rubber	1
11	Body	Ductile Iron	1
12	Stem	304 Stainless Steel	1
13	Wedge Nut	Bronze	1
14	Resilient Wedge	EPDM Rubber Encapsulated Ductile Iron	1
15	Hex Nut, 1/2-13	304 Stainless Steel	2
17	Handwheel	Ductile Iron	1
19	Hex Head Bolt, 1/2-13 x 2"	304 Stainless Steel	2
29	Flat Washer, 3/8	304 Stainless Steel	1
49	O-ring	Rubber	1
50	Spirol Pin, 5/16 x 1-1/2"	302 Stainless Steel	1
65	Thrust Washer	304 Stainless Steel	2
69	Wedge Cover	Polymer	2

# SERIES 2500 - STANDARD NRS PARTS LIST, 2-1/2" & 3" SIZES



Ref No.	Description	Material	Qty.	
			Series 2500	
			2-1/2"	3"
1	Hex Head Bolt, 5/8-11 x 1"	Stainless Steel	1	1
2	Operating Nut, 2" Square	Ductile Iron	1	1
	Operating Nut, T-Head (Optional)		1	-
3	O-ring	Rubber	2	2
4	Lower Thrust Washer	Nylon	1	1
5	Stuffing Box Gasket	Rubber O-ring	1	1
6	Hex Head Bolt, 5/8-11 x 1-3/4"	Stainless Steel	2	2
7	Stuffing Box	Ductile Iron	1	1
8	Bonnet	Ductile Iron	1	1
10	Bonnet Gasket	Rubber	1	1
11	Body	Ductile Iron	1	1
12	Stem	Bronze	1	1
		Stainless Steel (Optional)		
14	Resilient Wedge	Bronze, Coated With EPDM Rubber	1	1
15	Hex Nut, 5/8-11	Stainless Steel	4	4
17	Handwheel	Ductile Iron	1	1
19	Hex Head Bolt, 5/8-11 x 2-1/4"	Stainless Steel	2	2
29	Flat Washer, 5/8	Stainless Steel	1	1
40	UL/FM Label	Film	1	1
49	O-ring	Rubber	1	1
50	Spirol Pin, 5/16 x 1-1/2"	Stainless Steel	1	1
65	Upper Thrust Washer	Stainless Steel	1	1

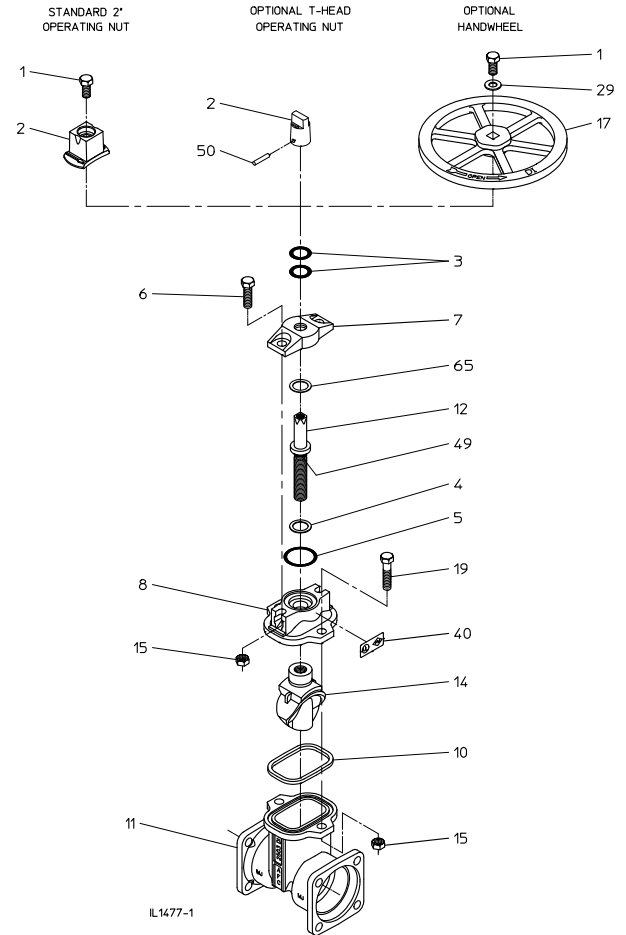

# SERIES 2500 - STANDARD NRS PARTS LIST, 4"-8" SIZES



Ref No	Description	Material	Qty.		
			Series 2500-1		
			4"	6"	8"
1	Hex Head Bolt, 5/8-11 x 1"	Stainless Steel	1	1	1
2	Operating Nut, 2" Square	Ductile Iron	1	1	1
3	O-ring	Rubber	2	2	2
5	Stuffing Box Gasket	Rubber O-ring	1	1	1
6	Hex Head Bolt, 5/8-11 x 1-3/4"	Stainless Steel	2	2	2
7	Stuffing Box	Ductile Iron	1	1	1
8	Bonnet	Ductile Iron	1	1	1
9	Hex Head Bolt, 5/8-11 x 2"	Stainless Steel	4	-	-
10	Bonnet Gasket	Rubber	1	1	1
11	Body	Ductile Iron	1	1	1
12	Stem	Bronze	1	1	1
		Stainless Steel (Optional)			
13	Wedge Nut	Bronze	1	1	1
14	Resilient Wedge	Ductile Iron, Encapsulated With EPDM Rubber	1	1	1
15	Hex Nut, 5/8-11	Stainless Steel	6	8	10
17	Handwheel	Ductile Iron	1	1	1
19	Hex Head Bolt, 5/8-11 x 2-1/4"	Stainless Steel	-	6	-
21	Hex Head Bolt, 5/8-11 x 2-1/2"	Stainless Steel	-	-	8
29	Flat Washer, 5/8	Stainless Steel	1	1	1
40	UL/FM Label	Film	1	1	1
49	O-ring	Rubber	1	1	1
65	Thrust Washer	Stainless Steel	2	2	2
69	Wedge Cover	Polymer	2	2	2

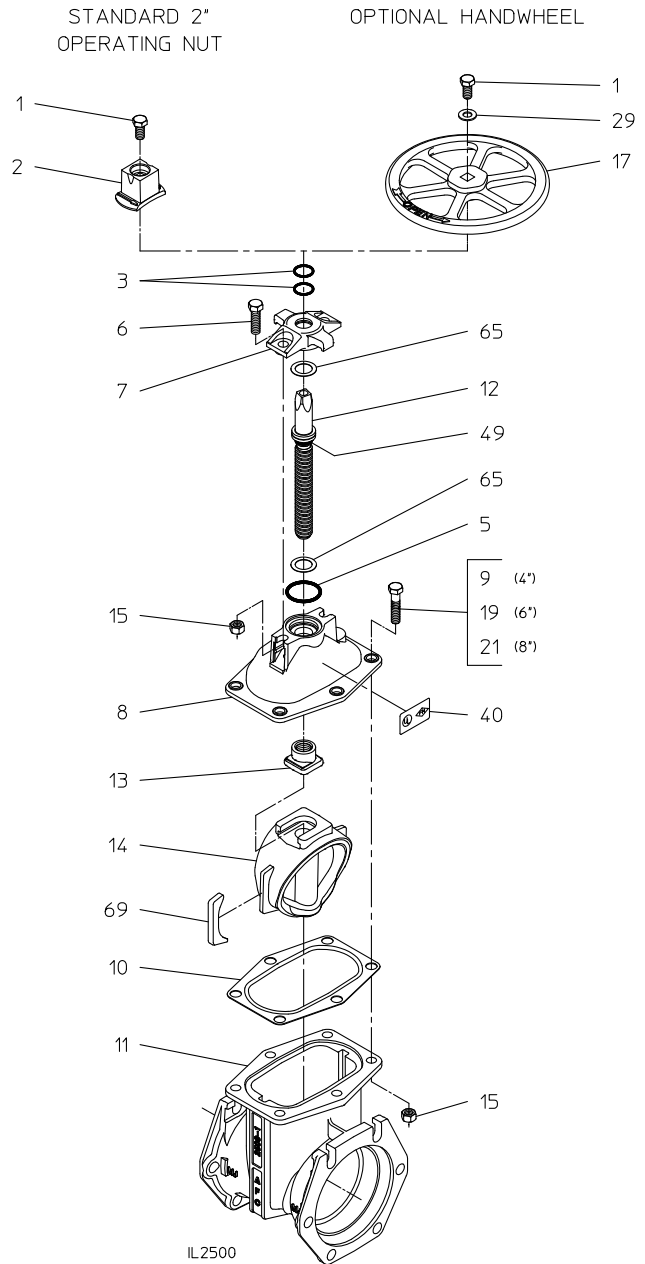

# SERIES 2500 - STANDARD NRS PARTS LIST, 10" & 12" SIZES



Ref No.	Description	Material	Qty.	
			Series 2500-1	
			10"	12"
1	Hex Head Bolt, 5/8-11 x 1"	Stainless Steel	1	1
2	Operating Nut, 2" Square	Ductile Iron	1	1
3	O-ring	Rubber	2	2
5	Stuffing Box Gasket	Rubber O-ring	1	1
7	Stuffing Box	Ductile Iron	1	1
8	Bonnet	Ductile Iron	1	1
9	Hex Head Bolt, 5/8-11 x 2"	Stainless Steel	4	4
10	Bonnet Gasket	Rubber	1	1
11	Body	Ductile Iron	1	1
12	Stem	Bronze	1	1
		Stainless Steel (Optional)		
13	Wedge Nut	Bronze	1	1
14	Resilient Wedge	Ductile Iron, Encapsulated With EPDM Rubber	1	1
15	Hex Nut, 5/8-11	Stainless Steel	14	4
17	Handwheel	Ductile Iron	1	1
22	Hex Head Bolt, 5/8-11 x 2-3/4"	Stainless Steel	10	-
29	Flat Washer, 5/8	Stainless Steel	1	1
40	UL/FM Label	Film	1	1
41	Hex Head Bolt, 5/8"-11 x 1 1/2"	Stainless Steel	1	1
48	Hex Nut, 3/4-10	Stainless Steel	-	10
49	O-ring	Rubber	1	1
65	Thrust Washer	Stainless Steel	2	2
67	Hex Head Bolt, 3/4-10 x 3"	Stainless Steel	-	10
69	Wedge Cover	Polymer	2	2

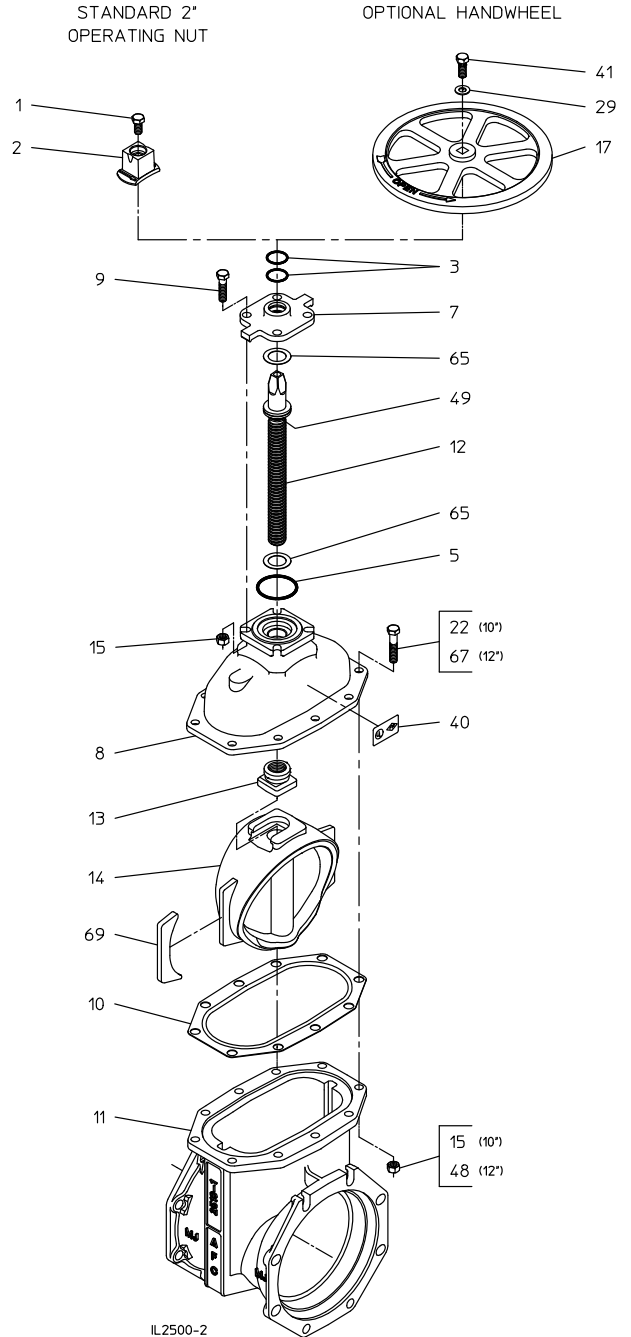



SERIES 2500 - NRS PARTS LIST, ALPHA™ & ALPHA™ XL RESTRAINED JOINT 4" - 8" SIZES

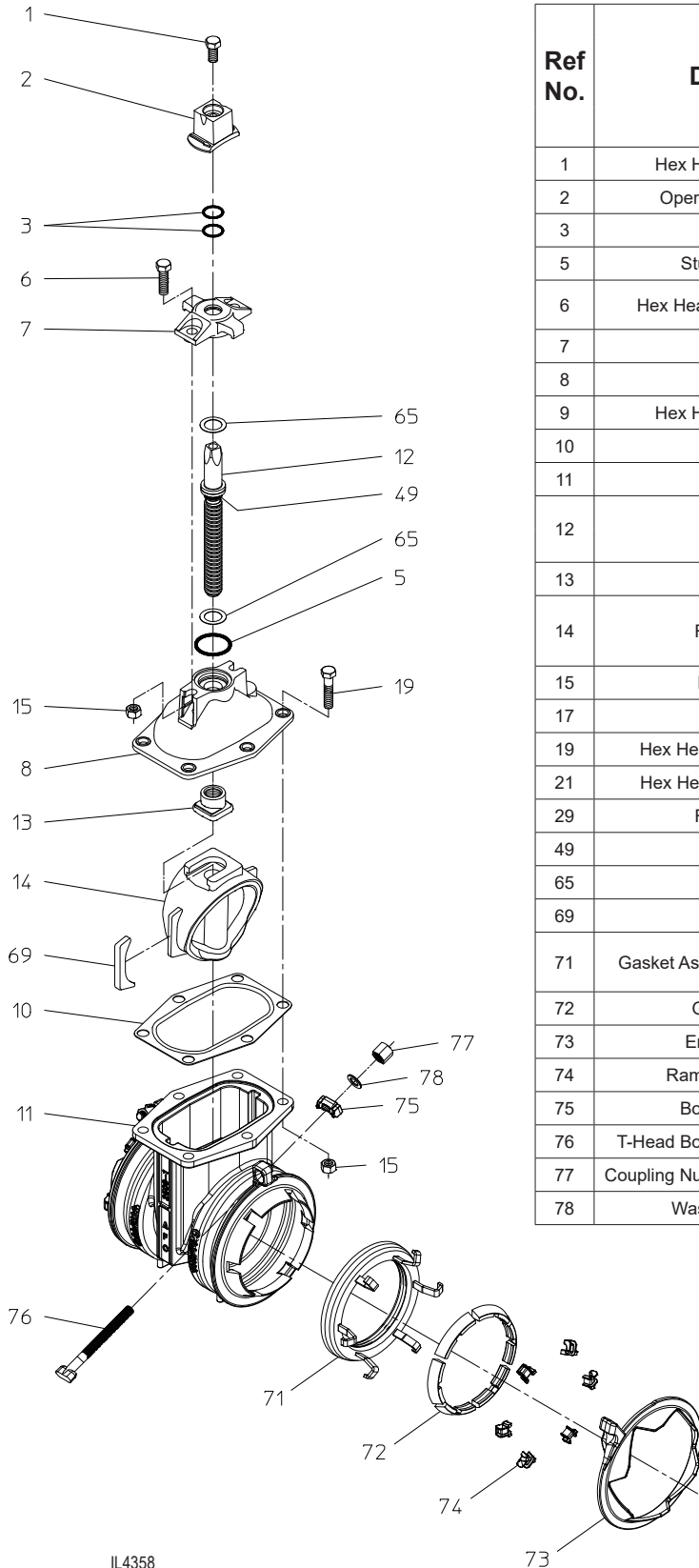

Ref No.	Description	Material	Qty.		
			Series 2500-1		
			4"	6"	8"
1	Hex Head Bolt, 5/8-11 x 1"	Stainless Steel	1	1	1
2	Operating Nut, 2" Square	Ductile Iron	1	1	1
3	O-ring	Rubber	2	2	2
5	Stuffing Box Gasket	Rubber O-ring	1	1	1
6	Hex Head Bolt, 5/8"-11 x 1-3/4"	Stainless Steel	2	2	2
7	Stuffing Box	Ductile Iron	1	1	1
8	Bonnet	Ductile Iron	1	1	1
9	Hex Head Bolt, 5/8-11 x 2"	Stainless Steel	4	-	-
10	Bonnet Gasket	Rubber	1	1	1
11	Body	Ductile Iron	1	1	1
12	Stem	Bronze	1	1	1
		Stainless Steel (Optional)			
13	Wedge Nut	Bronze	1	1	1
14	Resilient Wedge	Ductile Iron, Encapsulated With EPDM Rubber	1	1	1
15	Hex Nut, 5/8-11	Stainless Steel	6	8	10
17	Handwheel	Ductile Iron	1	1	1
19	Hex Head Bolt, 5/8-11 x 2-1/4"	Stainless Steel	-	6	-
21	Hex Head Bolt, 5/8-11 x 2 1/2"	Stainless Steel	-	-	8
29	Flat Washer, 5/8	Stainless Steel	1	1	1
49	O-ring	Rubber	1	1	1
65	Thrust Washer	Stainless Steel	2	2	2
69	Wedge Cover	Polymer	2	2	2
71	Gasket Assy (ALPHA or ALPHA XL)	NBR or SBR Rubber, ASTM D2000 304 Stainless Steel	2	2	2
72	Gripper (ALPHA)	Ductile Iron, ASTM A536	12	12	12
73	End Ring (ALPHA)	Ductile Iron, ASTM A536	2	2	2
74	Ramp Runner (ALPHA)	Nylon	12	12	12
75	Bolt Guide (ALPHA)	Ductile Iron, ASTM A536	2	2	2
76	T-Head Bolt, 5/8-11 x 7.25" (ALPHA)	Stainless Steel	2	2	2
77	Coupling Nut, 5/8-11 x 1-1/16" (ALPHA)	Stainless Steel	2	2	2
78	Washer, 5/8" (ALPHA)	Stainless Steel	2	2	2

SERIES 2500 - NRS PARTS LIST, ALPHA™ & ALPHA™ XL RESTRAINED JOINT 10" - 12" SIZES

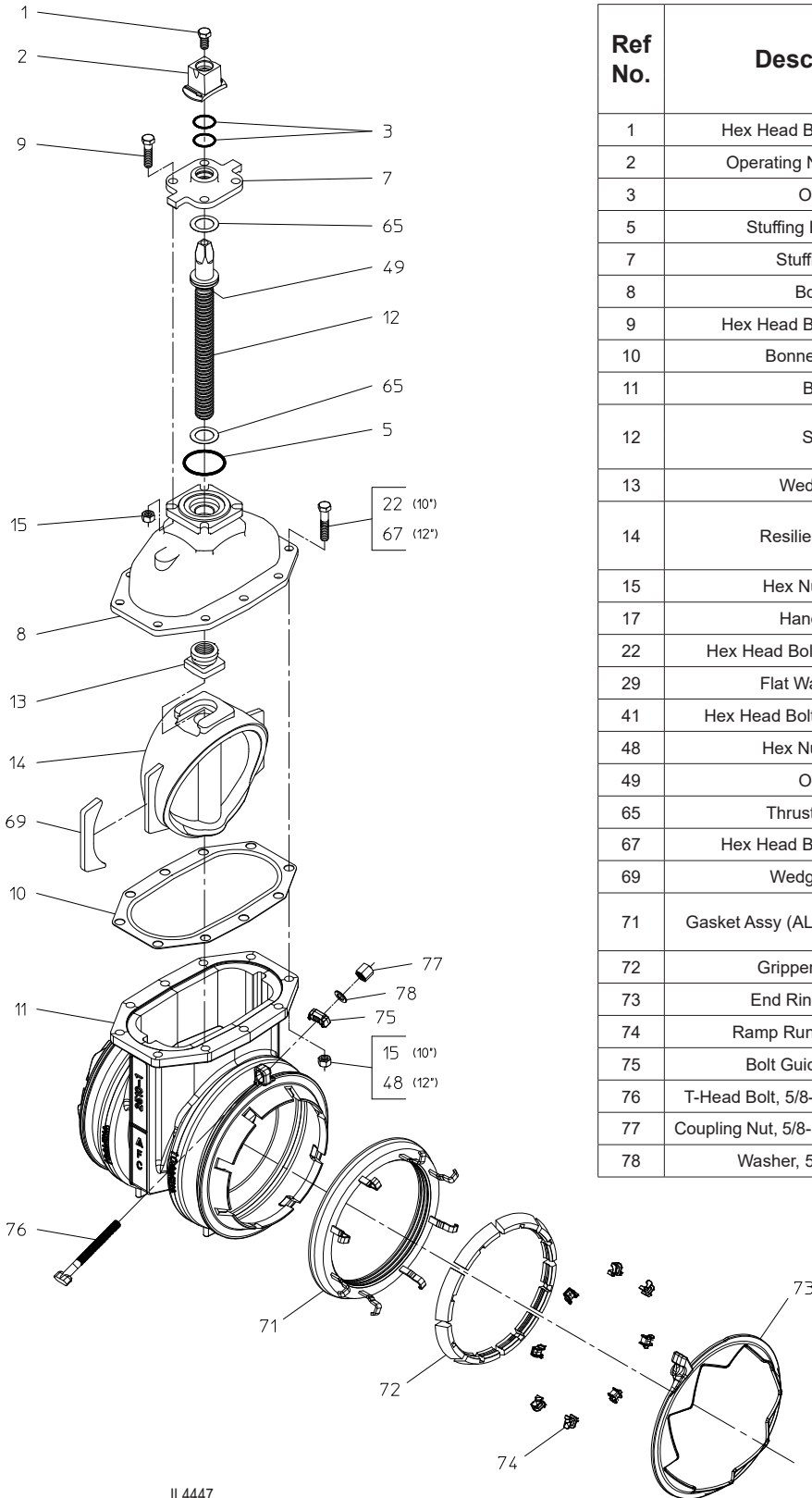

Ref No.	Description	Material	Qty.	
			Series 2500-1	
			10"	12"
1	Hex Head Bolt, 5/8-11 x 1"	Stainless Steel	1	1
2	Operating Nut, 2" Square	Ductile Iron	1	1
3	O-ring	Rubber	2	2
5	Stuffing Box Gasket	Rubber O-ring	1	1
7	Stuffing Box	Ductile Iron	1	1
8	Bonnet	Ductile Iron	1	1
9	Hex Head Bolt, 5/8-11 x 2"	Stainless Steel	4	4
10	Bonnet Gasket	Rubber	1	1
11	Body	Ductile Iron	1	1
12	Stem	Bronze Stainless Steel (Optional)	1	1
13	Wedge Nut	Bronze	1	1
14	Resilient Wedge	Ductile Iron, Encapsulated With EPDM Rubber	1	1
15	Hex Nut, 5/8-11	Stainless Steel	14	4
17	Handwheel	Ductile Iron	1	1
22	Hex Head Bolt, 5/8-11 x 2-3/4"	Stainless Steel	10	-
29	Flat Washer, 5/8	Stainless Steel	1	1
41	Hex Head Bolt, 5/8"-11 x 1 1/2"	Stainless Steel	1	1
48	Hex Nut, 3/4-10	Stainless Steel	-	10
49	O-ring	Rubber	1	1
65	Thrust Washer	Stainless Steel	2	2
67	Hex Head Bolt, 3/4-10 x 3"	Stainless Steel	-	10
69	Wedge Cover	Polymer	2	2
71	Gasket Assy (ALPHA or ALPHA XL)	NBR or SBR Rubber, ASTM D2000 304 Stainless Steel	2	2
72	Gripper (ALPHA)	Ductile Iron, ASTM A536	16	16
73	End Ring (ALPHA)	Ductile Iron, ASTM A536	2	2
74	Ramp Runner (ALPHA)	Nylon	16	16
75	Bolt Guide (ALPHA)	Ductile Iron, ASTM A536	2	2
76	T-Head Bolt, 5/8-11 x 7.25" (ALPHA)	Stainless Steel	2	2
77	Coupling Nut, 5/8-11 x 1-1/16" (ALPHA)	Stainless Steel	2	2
78	Washer, 5/8" (ALPHA)	Stainless Steel	2	2

IL4447

# SERIES 2500 - STANDARD NRS PARTS LIST, 14"-24" SIZES



Ref No.	Description	Material	Qty.				
			Series 2500				
			14"	16"	18"	20"	24"
1	Hex Head Bolt, 5/8-11 x 1-3/4"	Stainless Steel	1	1	1	1	1
2	Operating Nut, 2" Square	Ductile Iron	1	1	1	1	1
3	O-ring	Rubber	2	2	2	2	2
4	Upper Thrust Washer	Delrin	1	1	1	1	1
5	Stuffing Box Gasket	Rubber O-ring	1	1	1	1	1
6	O-ring	Rubber	1	1	1	1	1
7	Stuffing Box	Ductile Iron	1	1	1	1	1
8	Bonnet	Ductile Iron	1	1	1	1	1
9	Hex Head Bolt, 7/8-9 x 3"	Stainless Steel	4	4	4	-	-
9	Hex Head Bolt, 7/8-9 x 4"	Stainless Steel	-	-	-	4	4
10	Bonnet Gasket	Rubber	1	1	1	1	1
11	Body	Ductile Iron	1	1	1	1	1
12	Stem	Bronze	1	1	1	1	1
		Stainless Steel (Optional)					
13	Wedge Nut	Bronze	1	1	1	1	1
14	Resilient Wedge	Ductile Iron, Coated With EPDM Rubber	1	1	1	1	1
15	Wedge Cover	Polymer	2	2	2	2	2
16	Wedge Cover Pin	Polymer	2	4	4	2	2
17	Hex Head Bolt, 3/4-10 x 3-1/2"	Stainless Steel	14	16	-	-	-
17	Hex Head Bolt, 7/8-9 x 4"	Stainless Steel	-	-	16	-	-
17	Hex Head Bolt, 7/8-9 x 4-1/2"	Stainless Steel	-	-	-	18	-
17	Hex Head Bolt, 7/8-9 x 5"	Stainless Steel	-	-	-	-	20
18	Hex Nut, 3/4-10	Stainless Steel	14	16	-	-	-
18	Hex Nut, 7/8-9	Stainless Steel	-	-	16	18	20
19	Hex Nut, 7/8-9	Stainless Steel	4	4	4	4	4
20	Pipe Plug, 3/8 NPT	Stainless Steel	1	1	1	1	1
21	Lower Thrust Washer	Delrin	1	1	1	1	1

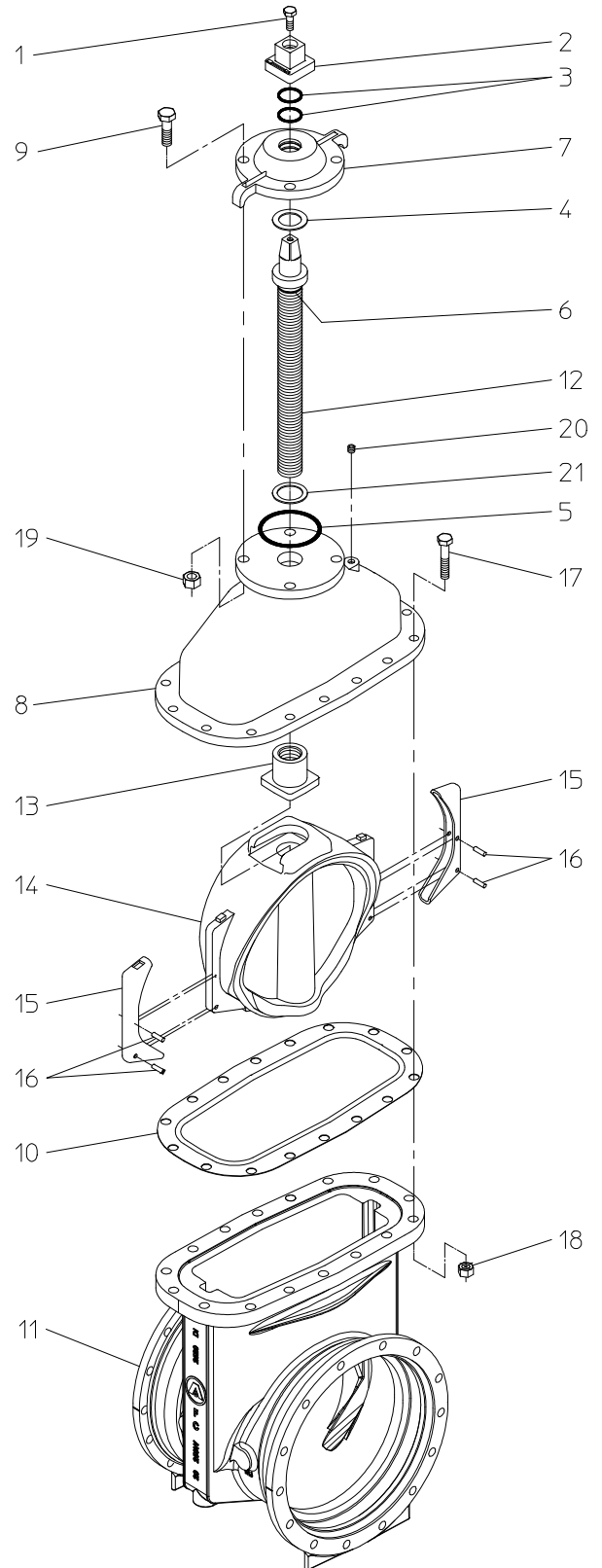

IL1507-2

# SERIES 2500 - NRS WITH ENCLOSED MITER GEARING PARTS LIST

## 3" - 12" SIZES

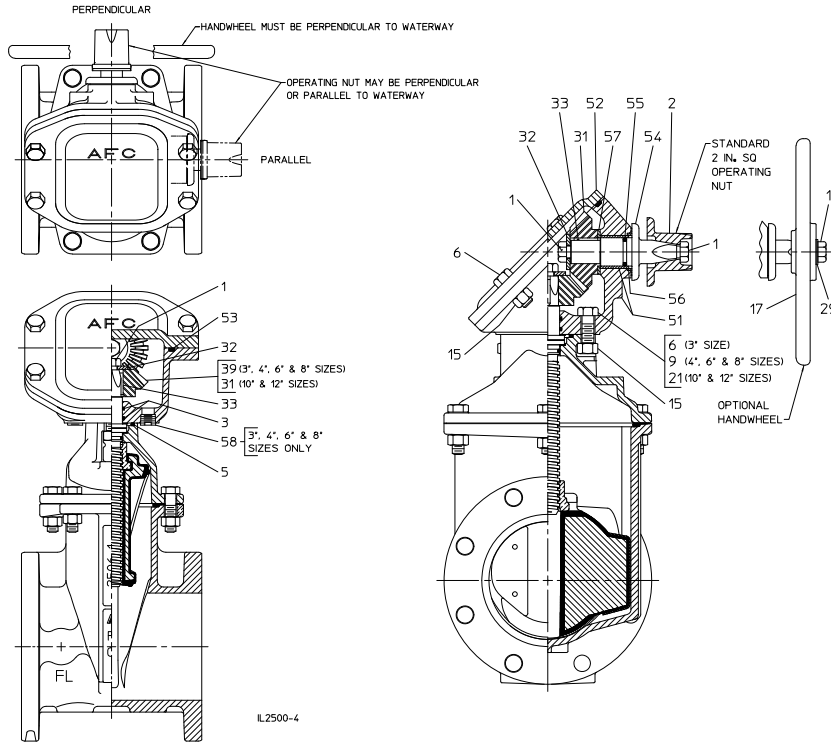

Ref. No.	Description	Material	Qty.					
			Series 2500	Series 2500-1				
				3"	4"	6"	8"	10"
1	Hex Head Bolt, 5/8-11 x 1"	Stainless Steel	3	3	3	3	3	3
2	Operating nut, 2" Square	Ductile Iron	1	1	1	1	1	1
3	O-ring	Rubber	2	2	2	2	2	2
5	Stuffing Box Gasket	Rubber	1	1	1	1	1	1
6	Hex Head Bolt, 5/8-11 x 1-3/4"	Stainless Steel	6	4	4	4	4	4
9	Hex Head Bolt, 5/8-11 x 2"	Stainless Steel	-	2	2	2	-	-
15	Hex Nut, 5/8-11	Stainless Steel	6	6	6	6	8	8
17	Handwheel (Optional)	Ductile Iron	1	1	1	1	1	1
21	Hex Head Bolt, 5/8-11 x 2-1/2"	Stainless Steel	-	-	-	-	4	4
29	Flat Washer, 5/8	Stainless Steel	1	1	1	1	1	1
31	Miter Gear	Steel	1	1	1	1	2	2
32	Flat Washer	Aluminum	2	2	2	2	2	2
33	Square Key, 1/4"	Stainless Steel	2	2	2	2	2	2
39	Miter Gaers	Steel	1	1	1	1	-	-
51	Gear Housing Assembly	Ductile Iron with Sintered Bronze Bushing	1	1	1	1	1	1
52	Gear Housing Cover	Ductile Iron	1	1	1	1	1	1
53	Housing Gasket	Rubber	1	1	1	1	1	1
54	Gear Shaft	Ductile Iron	1	1	1	1	1	1
55	O-ring	Rubber	1	1	1	1	1	1
56	Thrust Bearing	Bronze	1	1	1	1	1	1
57	Thrust Washer	Bronze	1	1	1	1	1	1
58	Headless Pipe Plug, 1/2 NPT	Brass	2	2	2	2	-	-

**NOTE:** See standard NRS dimension drawing and parts list drawing for dimensions and material descriptions not shown.

# SERIES 2500 - NRS WITH BEVEL GEARING PARTS LIST, 14" - 18" SIZES



Ref No.	Description	Material	Qty.		
			Series 2500		
			14"	16"	18"
1-K	Key 8 mm x 7 mm x 40 mm	Steel	1	1	1
2-K	Operating Nut, 2" Square	Ductile Iron	1	1	1
3	O-ring	Rubber	2	2	2
4	Upper Thrust Washer	Delrin	1	1	1
5	Stuffing Box Gasket	Rubber O-ring	1	1	1
6	O-ring	Rubber	1	1	1
7	Stuffing Box	Ductile Iron	1	1	1
8	Bonnet	Ductile Iron	1	1	1
9	Hex Head Bolt, 7/8-9 x 3"	Stainless Steel	4	4	4
10	Bonnet Gasket	Rubber	1	1	1
11	Body	Ductile Iron	1	1	1
12	Stem	Bronze	1	1	1
		Stainless Steel (Optional)			
13	Wedge Nut	Bronze	1	1	1
14	Resilient Wedge	Ductile Iron, Coated With EPDM Rubber	1	1	1
15	Wedge Cover	Polymer	2	2	2
16	Wedge Cover Pin	Polymer	2	4	4
17	Hex Head Bolt, 3/4-10 x 3-1/2"	Stainless Steel	14	16	-
17	Hex Head Bolt, 7/8-9 x 4"	Stainless Steel	-	-	16
18	Hex Nut, 3/4-10	Stainless Steel	14	16	-
18	Hex Nut, 7/8-9	Stainless Steel	-	-	16
19	Hex Nut, 7/8-9	Stainless Steel	4	4	4
20	Pipe Plug, 3/8 NPT	Stainless Steel	1	1	1
21	Lower Thrust Washer	Delrin	1	1	1
22	Stud, 5/8-11 x 2-3/4"	Stainless Steel	4	4	4
23	Hex Nut, 5/8-11	Stainless Steel	4	4	4
25	Square Key, 5/16 x 2-1/2	Hardened Steel	1	1	1
27	Bevel Gear Operator 2:1	Rotork IB5	1	1	1
29	Actuator Gasket	Rubber O-ring	1	1	1
30	Hex Head Bolt, 3/8-16 x 3/4"	Zinc Plated Steel	1	1	1
31	Washer	Steel	1	1	1
60-K	Spring Pin, 1/4 x 3/4"	Stainless Steel	1	1	1

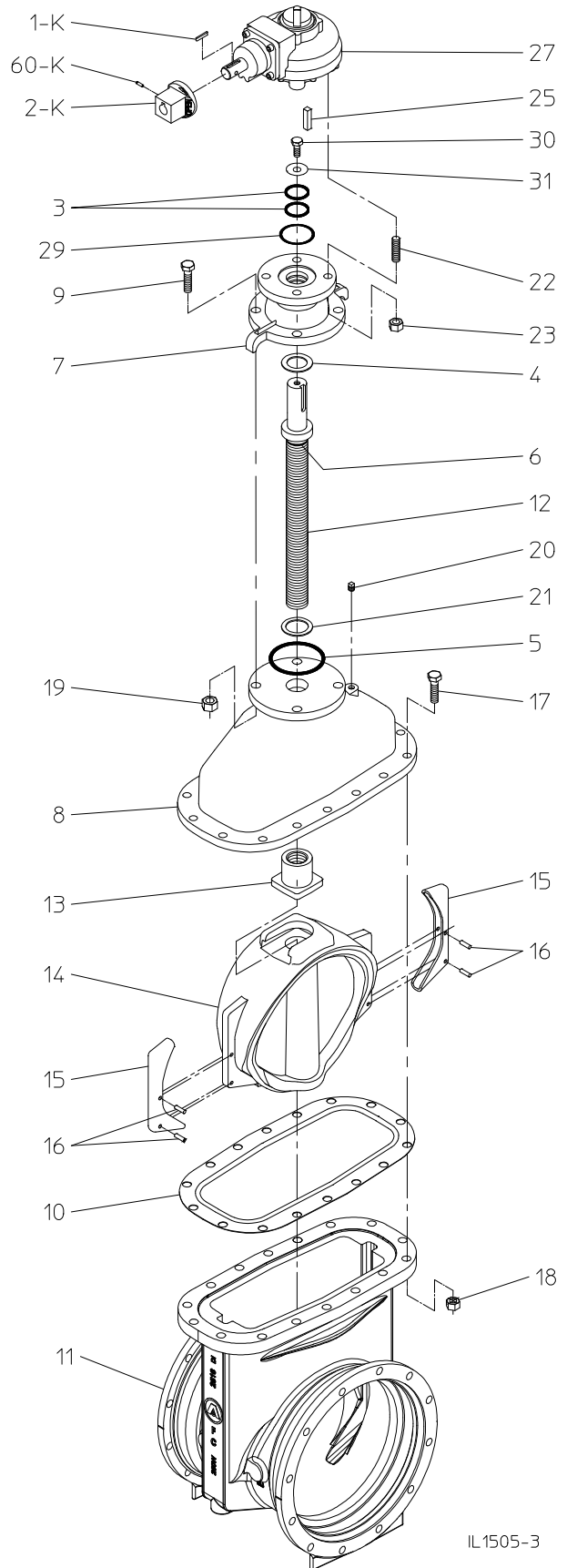

IL1505-3

# SERIES 2500 - NRS WITH BEVEL GEARING PARTS LIST, 20" & 24" SIZES



Ref No.	Description	Material	Qty.	
			Series 2500	
			20"	24"
1-K	Key 8 mm x 7 mm x 40 mm	Steel	1	1
2-K	Operating Nut, 2" Square	Ductile Iron	1	1
3	O-ring	Rubber	2	2
4	Upper Thrust Washer	Delrin	1	1
5	Stuffing Box Gasket	Rubber O-ring	1	1
6	O-ring	Rubber	1	1
7	Stuffing Box	Ductile Iron	1	1
8	Bonnet	Ductile Iron	1	1
10	Bonnet Gasket	Rubber	1	1
11	Body	Ductile Iron	1	1
12	Stem	Bronze Stainless Steel (Optional)	1	1
13	Wedge Nut	Bronze	1	1
14	Resilient Wedge	Ductile Iron, Coated With EPDM Rubber	1	1
15	Wedge Cover	Polymer	2	2
16	Wedge Cover Pin	Polymer	2	2
17	Hex Head Bolt, 7/8-9 x 4-1/2"	Stainless Steel	18	-
17	Hex Head Bolt, 7/8-9 x 5"	Stainless Steel	-	20
18	Hex Nut, 7/8-9	Stainless Steel	18	20
20	Pipe Plug, 3/8 NPT	Stainless Steel	1	1
21	Lower Thrust Washer	Delrin	1	1
22	Stud, 7/8-9 x 3-1/2"	Stainless Steel	4	4
23	Hex Nut, 7/8-9	Stainless Steel	4	4
25	Square Key, 1/2 x 2-3/4"	Hardened Steel	1	1
27	Bevel Gear Operator 3:1	Rotork IB7	1	1
28	Socket Head Cap Screw 3/4-10 x 2"	Stainless Steel	4	4
29	Actuator Gasket	Rubber O-ring	1	1
30	Hex Head Bolt, 1/2-13 x 1"	Zinc Plated Steel	1	1
31	Washer	Steel	1	1
60-K	Spring Pin, 1/4 x 3/4"	Stainless Steel	1	1

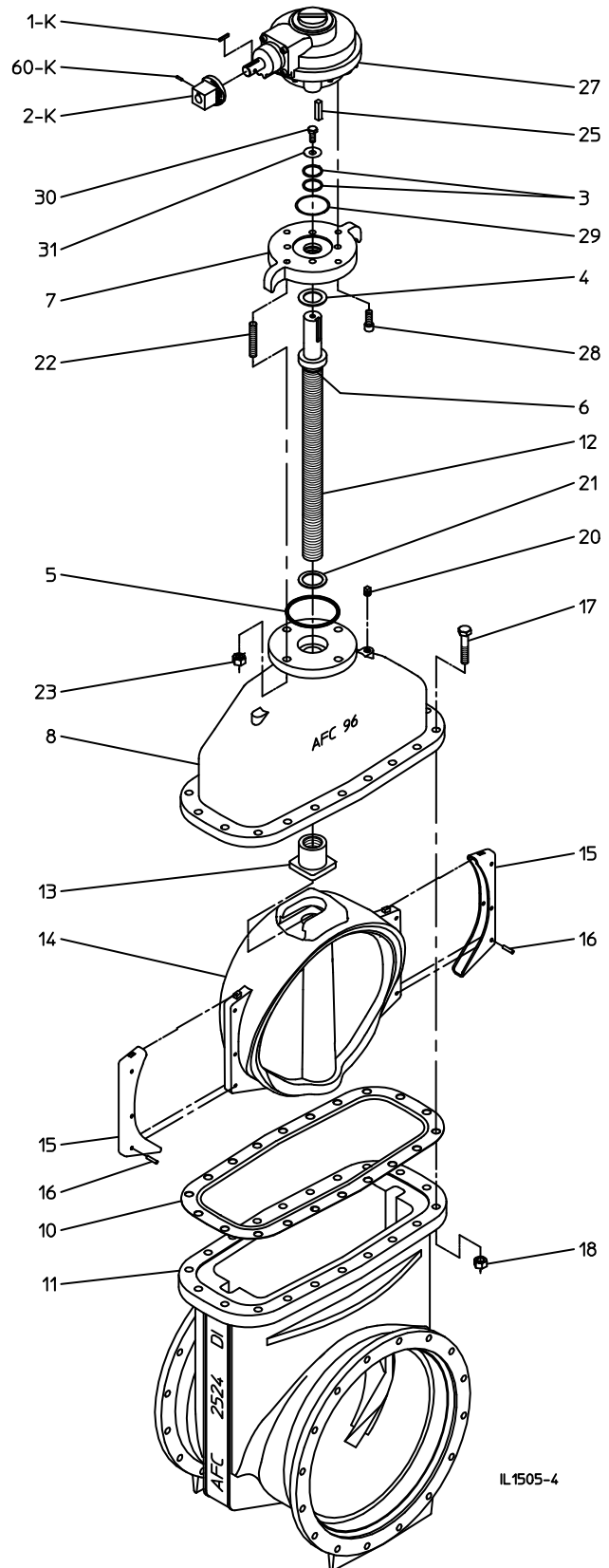

# SERIES 2500 - NRS WITH BEVEL GEARING PARTS LIST, 30" & 36" SIZES



Ref No.	Description	Material	Qty.	
			Series 2500	
			30"	36"
1-K	Key 8 mm x 7 mm x 40 mm	Steel	1	1
2-K	Operating Nut, 2" Square	Ductile Iron	1	1
3	O-ring	Rubber	2	2
4	Upper Thrust Washer	Delrin	1	1
5	Stuffing Box Gasket	Rubber O-ring	1	1
6	O-ring	Rubber	1	1
7	Stuffing Box	Ductile Iron	1	1
8	Bonnet	Ductile Iron	1	1
10	Bonnet Gasket	Rubber	1	-
10	Bonnet Gasket	EPDM Rubber	-	1
11	Body	Ductile Iron	1	1
12	Stem	Bronze	1	1
		Stainless Steel (Optional)		
13	Wedge Nut	Bronze	1	1
14	Resilient Wedge	Ductile Iron, Coated With EPDM Rubber	1	1
15	Wedge Cover	Polymer	2	2
16	Wedge Cover Pin	Polymer	2	2
17	Hex Head Bolt, 1-8 x 6"	Stainless Steel	24	-
17	Hex Head Bolt, 1-1/4-7 x 7"	Stainless Steel	-	28
18	Hex Nut, 1"-8	Stainless Steel	24	-
18	Hex Nut, 1-1/4-7	Stainless Steel	-	28
20	Pipe Plug, 3/8 NPT	Stainless Steel	4	4
21	Lower Thrust Washer	Delrin	1	1
22	Stud, 1"-8 x 6"	Stainless Steel	6	-
22	Stud, 1"-8 x 6-1/2"	Stainless Steel	-	8
23	Hex Nut, 1"-8	Stainless Steel	12	16
25	Square Key, 1/2 x 3-1/2	Hardened Steel	1	-
25	Square Key, 5/8 x 4"	Hardened Steel	-	1
27	Bevel Gear Operator 4:1	Rotork IB8	1	-
27	Bevel Gear Operator 4:1	Rotork IB10	-	1
28	Socket Head Cap Screw 3/4-10 x 2"	Stainless Steel	4	-
28	Socket Head Cap Screw 5/8-11 x 2"	Stainless Steel	-	8
29	Actuator Gasket	Rubber O-ring	1	1
30	Hex Head Bolt, 3/4-10 x 1"	Zinc Plated Steel	1	1
31	Washer	Steel	1	1
60-K	Spring Pin, 1/4 x 3/4"	Stainless Steel	1	1

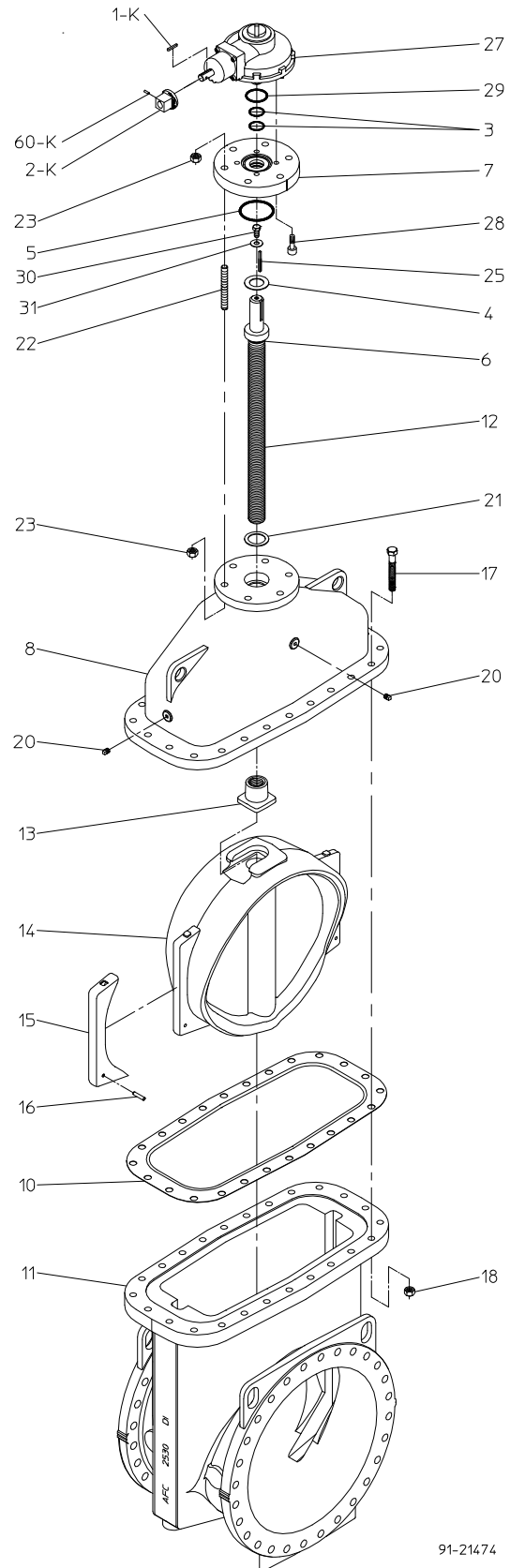

91-21474



# SERIES 2500 - NRS WITH BEVEL GEARING PARTS LIST, 42" - 54" SIZES



Ref No.	Description	Material	Qty.		
			Series 2500		
			42"	48"	54"
1-K	Key 14 mm x 9 mm x 54 mm	Steel	1	1	1
2-K	Operating Nut, 2" Square	Ductile Iron	1	1	1
3	O-ring	Rubber	2	2	2
4	Upper Thrust Washer	Delrin	1	1	1
5	Stuffing Box Gasket	Rubber O-ring	1	1	1
6	O-ring	Rubber	1	1	1
7	Stuffing Box	Ductile Iron	1	1	1
8	Bonnet	Ductile Iron	1	1	1
10	Bonnet Gasket	EPDM Rubber	1	1	1
11	Body	Ductile Iron	1	1	1
12	Stem	Bronze	1	1	1
		Stainless Steel (Optional)			
13	Wedge Nut	Bronze	1	1	1
14	Resilient Wedge	Ductile Iron, Coated With EPDM Rubber	1	1	1
15	Wedge Cover	Polymer	2	2	2
16	Wedge Cover Pin	Polymer	2	2	2
17	Hex Head Bolt, 1-1/4-7 x 7-1/2"	Stainless Steel	32	-	-
17	Hex Head Bolt, 1-3/8-6 x 8-1/2"	Stainless Steel	-	36	36
18	Hex Nut, 1-1/4-7	Stainless Steel	32	-	-
18	Hex Nut, 1-3/8-6	Stainless Steel	-	36	36
20	Pipe Plug, 1/2 NPT	Stainless Steel	4	4	4
21	Lower Thrust Washer	Delrin	1	1	1
22	Stud, 1-1/4-7 x 7-1/2"	Stainless Steel	8	-	-
22	Stud, 1-1/4-7 x 7-3/4"	Stainless Steel	-	8	8
23	Hex Nut, 1-1/4-7	Stainless Steel	16	16	16
25	Square Key, 3/4 x 4-1/2	Hardened Steel	1	1	1
27	Bevel Gear Operator 8:1	Rotork IB12	1	1	1
28	Socket Head Cap Screw 3/4-10 x 2-1/2"	Stainless Steel	8	8	8
29	Actuator Gasket	Rubber O-ring	1	1	1
30	Hex Head Bolt, 7/8-9 x 1-1/2"	Zinc Plated Steel	1	1	1
31	Washer	Steel	1	1	1
50-K	Set Screw 5/16-18 x 3/4"	Stainless Steel	1	1	1

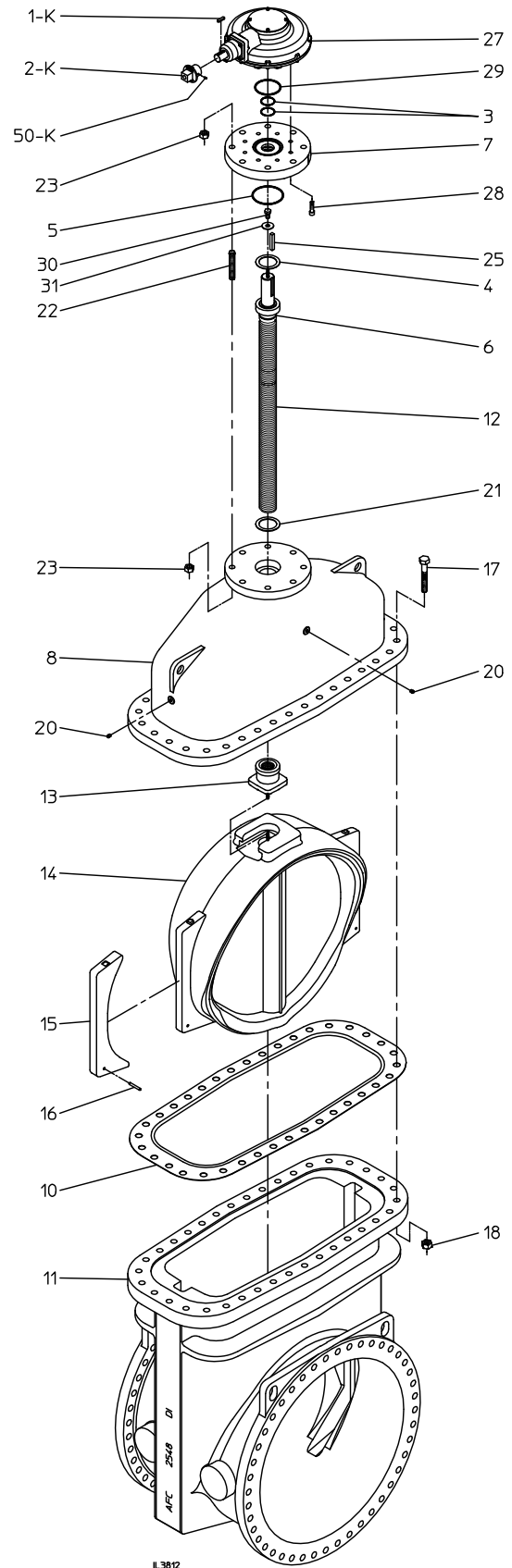



# SERIES 2500 - NRS WITH BEVEL GEARING PARTS LIST, 60" & 66" SIZES



Ref No.	Description	Material	Qty.	
			Series 2500	
			60"	66"
1-K	Key 14 mm x 9 mm x 54 mm	Steel	1	1
2-K	Operating Nut, 2" Square	Ductile Iron	1	1
3	O-ring	Rubber	2	2
4	Upper Thrust Washer	Delrin	1	1
5	Stuffing Box Gasket	Rubber O-ring	1	1
6	O-ring	Rubber	1	1
7	Stuffing Box	Ductile Iron	1	1
8	Bonnet	Ductile Iron	1	1
10	Bonnet Gasket	EPDM Rubber	1	1
11	Body	Ductile Iron	1	1
12	Stem	Stainless Steel	1	1
13	Wedge Nut	Bronze	1	1
14	Resilient Wedge	Ductile Iron, Coated With EPDM Rubber	1	1
15	Wedge Cover	Polymer	4	4
16	Wedge Cover Pin	Polymer	4	4
17	Hex Head Bolt, 1-3/8-6 x 8-1/2"	Stainless Steel	32	32
18	Hex Nut, 1-3/8-6	Stainless Steel	32	32
20	Pipe Plug, 1/2 NPT	Stainless Steel	4	4
21	Lower Thrust Washer	Delrin	1	1
22	Stud, 1-1/4-7 x 7-1/2"	Stainless Steel	8	8
23	Hex Nut, 1-1/4-7	Stainless Steel	16	16
25	Square Key, 3/4 x 4-1/2	Hardened Steel	1	1
27	Bevel Gear Operator 8:1	Rotork IB12	1	1
28	Socket Head Cap Screw 3/4-10 x 2-1/2"	Stainless Steel	8	8
29	Actuator Gasket	Rubber O-ring	1	1
30	Hex Head Bolt, 7/8-9 x 1-1/2"	Plated Steel	1	1
31	Washer	Steel	1	1
50-K	Set Screw 5/16-18 x 3/4"	Stainless Steel	1	1
55	Blind Flange**	Ductile Iron	1	1
56	Stud, 5/8-11 x 3"	Stainless Steel	8	8
57	Hex Nut, 5/8-11	Stainless Steel	8	8
83	Blind Flange Gasket	Rubber	2	2

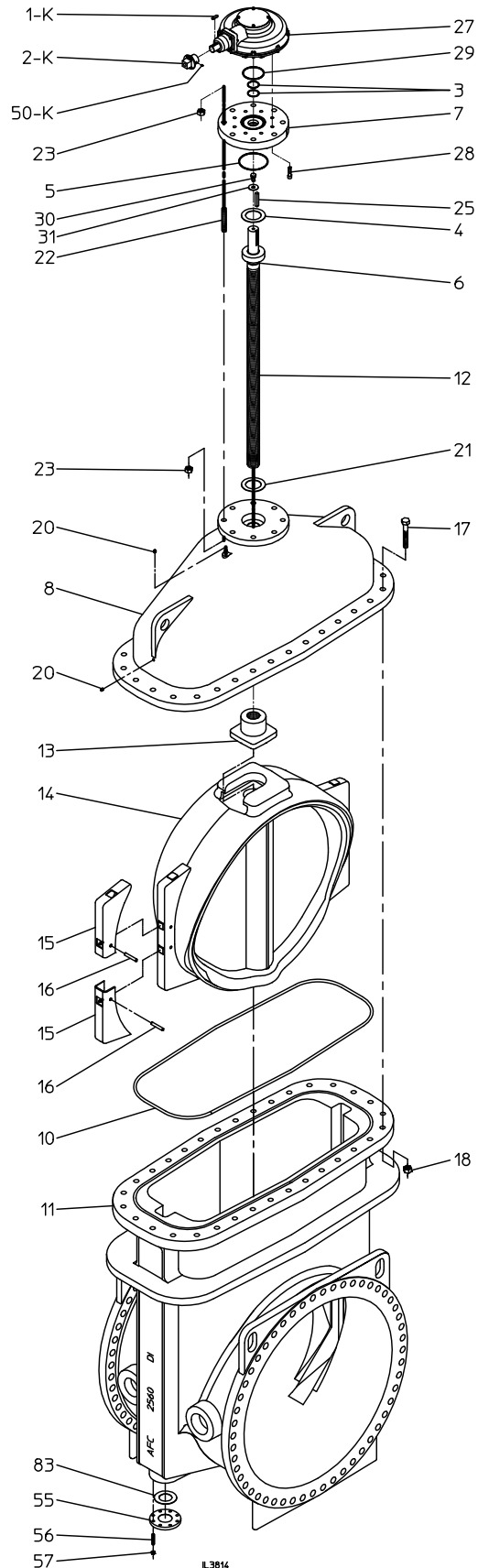

\*\* On horizontal configurations, the blind flange (Ref. # 55) will be located on the bottom of the valve guide track, opposite the direction in which the bevel gear input shaft is installed.

# SERIES 2500 - NRS WITH SPUR GEARING PARTS LIST, 14" - 18" SIZES



Ref No.	Description	Material	Qty.		
			Series 2500		
			14"	16"	18"
1-K	Key 8 mm x 7 mm x 40 mm	Steel	1	1	1
2-K	Operating Nut, 2" Square	Ductile Iron	1	1	1
3	O-ring	Rubber	2	2	2
4	Upper Thrust Washer	Delrin	1	1	1
5	Stuffing Box Gasket	Rubber O-ring	1	1	1
6	O-ring	Rubber	1	1	1
7	Stuffing Box	Ductile Iron	1	1	1
8	Bonnet	Ductile Iron	1	1	1
9	Hex Head Bolt, 7/8-9 x 3"	Stainless Steel	4	4	4
10	Bonnet Gasket	Rubber	1	1	1
11	Body	Ductile Iron	1	1	1
12	Stem	Bronze	1	1	1
		Stainless Steel (Optional)			
13	Wedge Nut	Bronze	1	1	1
14	Resilient Wedge	Ductile Iron, Coated With EPDM Rubber	1	1	1
15	Wedge Cover	Polymer	2	2	2
16	Wedge Cover Pin	Polymer	2	4	4
17	Hex Head Bolt, 3/4-10 x 3-1/2"	Stainless Steel	14	16	-
17	Hex Head Bolt, 7/8-9 x 4"	Stainless Steel	-	-	16
18	Hex Nut, 3/4-10	Stainless Steel	14	16	-
18	Hex Nut, 7/8-9	Stainless Steel	-	-	16
19	Hex Nut, 7/8-9	Stainless Steel	4	4	4
20	Pipe Plug, 3/8 NPT	Stainless Steel	1	1	1
21	Lower Thrust Washer	Delrin	1	1	1
22	Stud, 5/8-11 x 2-3/4"	Stainless Steel	4	4	4
23	Hex Nut, 5/8-11	Stainless Steel	4	4	4
24	Spur Gear Operator 2:1	Rotork IS5	1	1	1
25	Square Key, 5/16 x 2-1/2	Hardened Steel	1	1	1
29	Actuator Gasket	Rubber O-ring	1	1	1
30	Hex Head Bolt, 3/8-16 x 3/4"	Zinc Plated Steel	1	1	1
31	Washer	Steel	1	1	1
60-K	Spring Pin, 1/4 x 3/4"	Stainless Steel	1	1	1

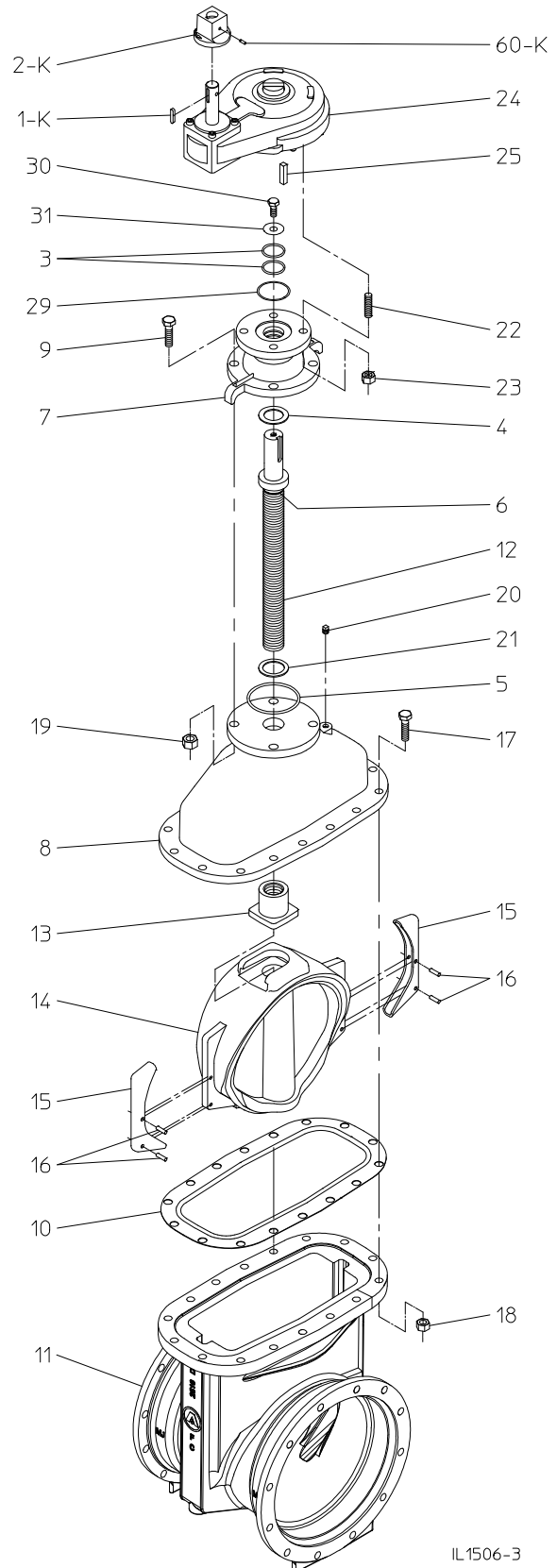

IL1506-3

# SERIES 2500 - NRS WITH SPUR GEARING PARTS LIST, 20" & 24" SIZES



Ref No.	Description	Material	Qty.	
			Series 2500	
			20"	24"
1-K	Key 8 mm x 7 mm x 40 mm	Steel	1	1
2-K	Operating Nut, 2" Square	Ductile Iron	1	1
3	O-ring	Rubber	2	2
4	Upper Thrust Washer	Delrin	1	1
5	Stuffing Box Gasket	Rubber O-ring	1	1
6	O-ring	Rubber	1	1
7	Stuffing Box	Ductile Iron	1	1
8	Bonnet	Ductile Iron	1	1
10	Bonnet Gasket	Rubber	1	1
11	Body	Ductile Iron	1	1
12	Stem	Bronze	1	1
		Stainless Steel (Optional)		
13	Wedge Nut	Bronze	1	1
14	Resilient Wedge	Ductile Iron, Coated With EPDM Rubber	1	1
15	Wedge Cover	Polymer	2	2
16	Wedge Cover Pin	Polymer	2	2
17	Hex Head Bolt, 7/8-9 x 4-1/2"	Stainless Steel	18	-
17	Hex Head Bolt, 7/8-9 x 5"	Stainless Steel	-	20
18	Hex Nut, 7/8-9	Stainless Steel	18	20
20	Pipe Plug, 3/8 NPT	Stainless Steel	1	1
21	Lower Thrust Washer	Delrin	1	1
22	Stud, 7/8-9 x 3-1/2"	Stainless Steel	4	4
23	Hex Nut, 7/8-9	Stainless Steel	4	4
24	Spur Gear Operator 3:1	Rotork IS7	1	1
25	Square Key, 1/2 x 2-3/4	Hardened Steel	1	1
28	Socket Head Cap Screw 3/4-10 x 2"	Stainless Steel	4	4
29	Actuator Gasket	Rubber O-ring	1	1
30	Hex Head Bolt, 1/2-13 x 1"	Zinc Plated Steel	1	1
31	Washer	Steel	1	1
60-K	Spring Pin, 1/4 x 3/4"	Stainless Steel	1	1

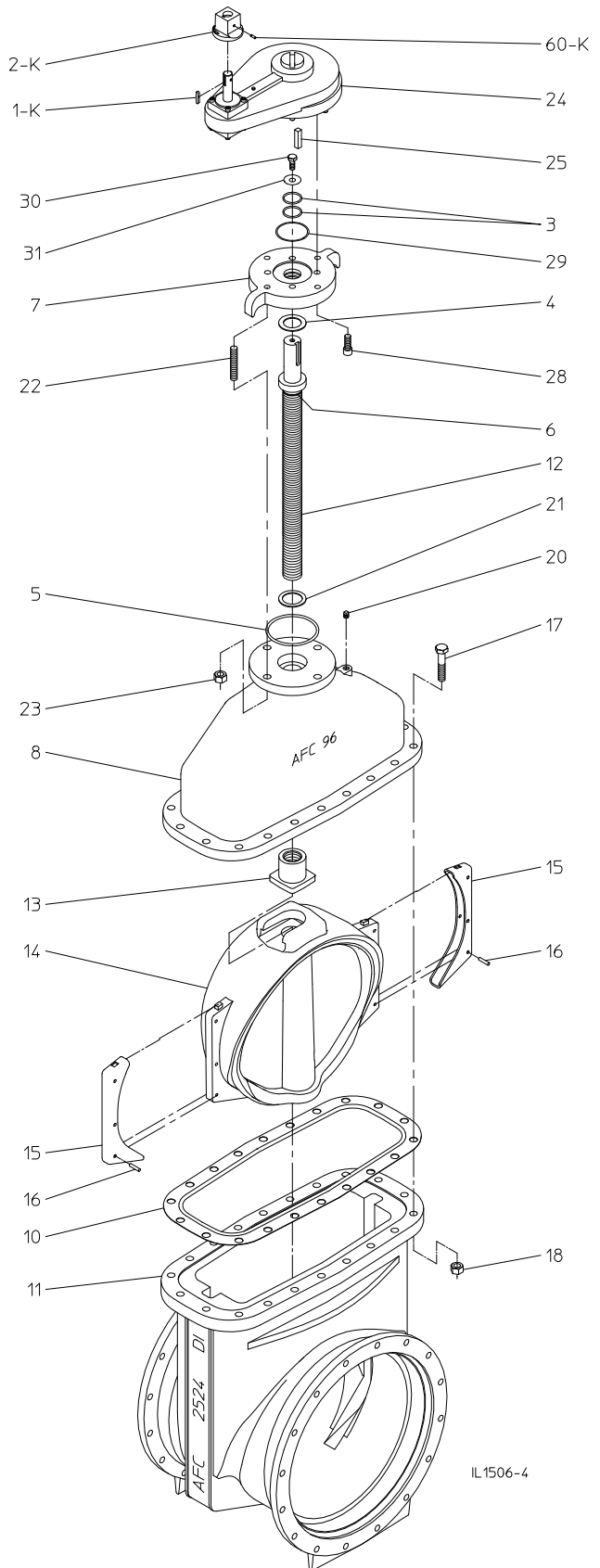

## SERIES 2500 - NRS WITH SPUR GEARING PARTS LIST, 30" & 36" SIZES



Ref No.	Description	Material	Qty.	
			Series 2500	
			30"	36"
1-K	Key 8 mm x 7 mm x 40 mm	Steel	1	1
2-K	Operating Nut, 2" Square	Ductile Iron	1	1
3	O-ring	Rubber	2	2
4	Upper Thrust Washer	Delrin	1	1
5	Stuffing Box Gasket	Rubber O-ring	1	1
6	O-ring	Rubber	1	1
7	Stuffing Box	Ductile Iron	1	1
8	Bonnet	Ductile Iron	1	1
10	Bonnet Gasket	Rubber	1	-
10	Bonnet Gasket	EPDM Rubber	-	1
11	Body	Ductile Iron	1	1
12	Stem	Bronze	1	1
		Stainless Steel (Optional)		
13	Wedge Nut	Bronze	1	1
14	Resilient Wedge	Ductile Iron, Coated With EPDM Rubber	1	1
15	Wedge Cover	Polymer	2	2
16	Wedge Cover Pin	Polymer	2	2
17	Hex Head Bolt, 1"-8 x 6"	Stainless Steel	24	-
17	Hex Head Bolt, 1-1/4-7 x 7"	Stainless Steel	-	28
18	Hex Nut, 1"-8	Stainless Steel	24	-
18	Hex Nut, 1-1/4-7	Stainless Steel	-	28
20	Pipe Plug, 3/8 NPT	Stainless Steel	4	4
21	Lower Thrust Washer	Delrin	1	1
22	Stud, 1"-8 x 6"	Stainless Steel	6	-
22	Stud, 1"-8 x 6-1/2"	Stainless Steel	-	8
23	Hex Nut, 1"-8	Stainless Steel	12	16
24	Spur Gear Operator 4:1	Rotork IS8	1	-
24	Spur Gear Operator 4:1	Rotork IS10	-	1
25	Square Key, 1/2 x 3-1/2	Hardened Steel	1	-
25	Square Key, 5/8 x 4"	Hardened Steel	-	1
28	Socket Head Cap Screw 3/4-10 x 2"	Stainless Steel	4	-
28	Socket Head Cap Screw 5/8-11 x 2"	Stainless Steel	-	8
29	Actuator Gasket	Rubber O-ring	1	1
30	Hex Head Bolt, 3/4-10 x 1"	Zinc Plated Steel	1	1
31	Washer	Steel	1	1
60-K	Spring Pin, 1/4 x 3/4"	Stainless Steel	1	1

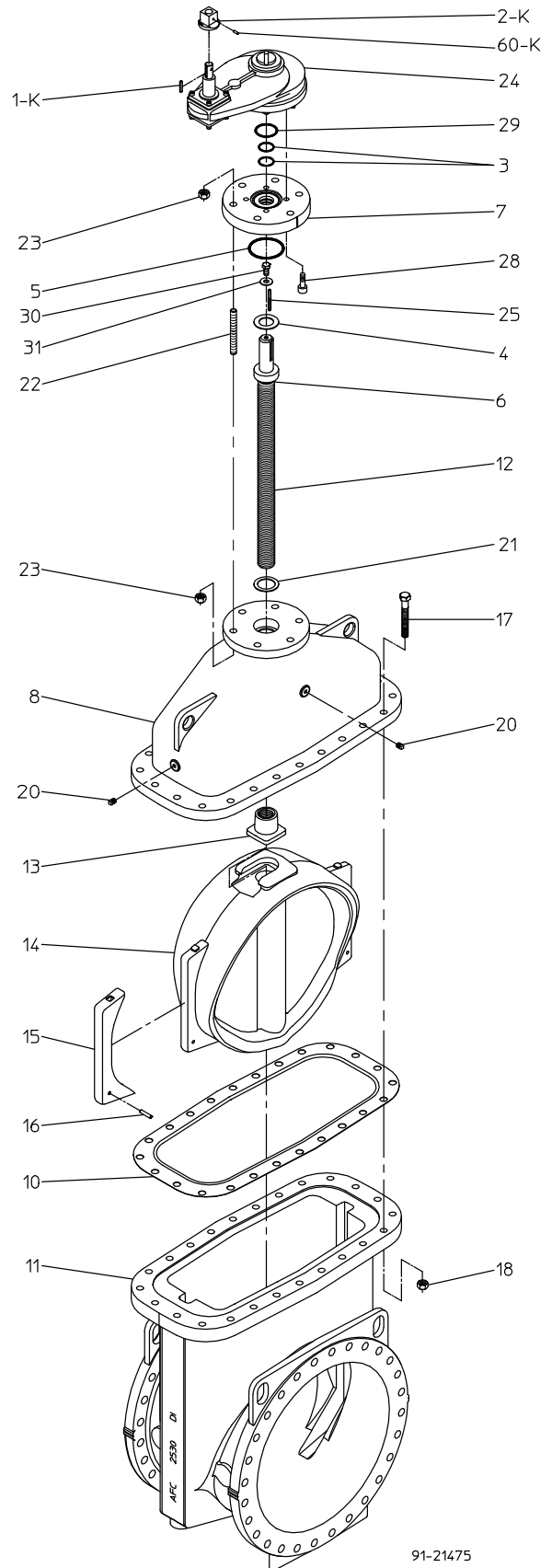

91-21475

# SERIES 2500 - NRS WITH SPUR GEARING PARTS LIST, 42" - 54" SIZES



Ref No.	Description	Material	Qty.		
			Series 2500		
			42"	48"	54"
1-K	Key 14 mm x 9 mm x 54 mm	Steel	1	1	1
2-K	Operating Nut, 2" Square	Ductile Iron	1	1	1
3	O-ring	Rubber	2	2	2
4	Upper Thrust Washer	Delrin	1	1	1
5	Stuffing Box Gasket	Rubber O-ring	1	1	1
6	O-ring	Rubber	1	1	1
7	Stuffing Box	Ductile Iron	1	1	1
8	Bonnet	Ductile Iron	1	1	1
10	Bonnet Gasket	EPDM Rubber	1	1	1
11	Body	Ductile Iron	1	1	1
12	Stem	Bronze	1	1	1
		Stainless Steel (Optional)			
13	Wedge Nut	Bronze	1	1	1
14	Resilient Wedge	Ductile Iron, Coated With EPDM Rubber	1	1	1
15	Wedge Cover	Polymer	2	2	2
16	Wedge Cover Pin	Polymer	2	2	2
17	Hex Head Bolt, 1-1/4-7 x 7-1/2"	Stainless Steel	32	-	-
17	Hex Head Bolt, 1-3/8-6 x 8-1/2"	Stainless Steel	-	36	36
18	Hex Nut, 1-1/4-7	Stainless Steel	32	-	-
18	Hex Nut, 1-3/8-6	Stainless Steel	-	36	36
20	Pipe Plug, 1/2 NPT	Stainless Steel	4	4	4
21	Lower Thrust Washer	Delrin	1	1	1
22	Stud, 1-1/4-7 x 7-1/2"	Stainless Steel	8	-	-
22	Stud, 1-1/4-7 x 7-3/4"	Stainless Steel	-	8	8
23	Hex Nut, 1-1/4-7	Stainless Steel	16	16	16
24	Spur Gear Operator 8:1	Rotork IS12	1	1	1
25	Square Key, 3/4 x 4-1/2	Hardened Steel	1	1	1
28	Socket Head Cap Screw 3/4-10 x 2-1/2"	Stainless Steel	8	8	8
29	Actuator Gasket	Rubber O-ring	1	1	1
30	Hex Head Bolt, 7/8-9 x 1-1/2"	Plated Steel	1	1	1
31	Washer	Steel	1	1	1
50-K	Set Screw 5/16-18 x 3/4"	Stainless Steel	1	1	1

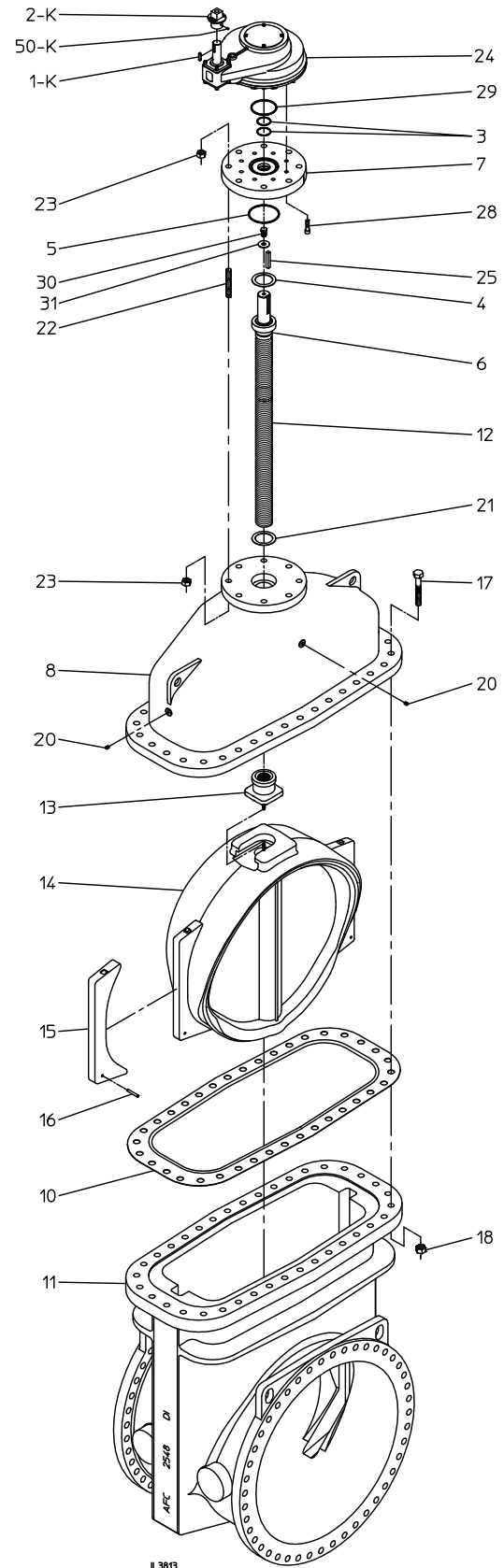

# SERIES 2500 - NRS WITH SPUR GEARING PARTS LIST, 60" & 66" SIZES



Ref No.	Description	Material	Qty.	
			Series 2500	
			60"	66"
1-K	Key 14 mm x 9 mm x 54 mm	Steel	1	1
2-K	Operating Nut, 2" Square	Ductile Iron	1	1
3	O-ring	Rubber	2	2
4	Upper Thrust Washer	Delrin	1	1
5	Stuffing Box Gasket	Rubber O-ring	1	1
6	O-ring	Rubber	1	1
7	Stuffing Box	Ductile Iron	1	1
8	Bonnet	Ductile Iron	1	1
10	Bonnet Gasket	EPDM Rubber	1	1
11	Body	Ductile Iron	1	1
12	Stem	Stainless Steel	1	1
13	Wedge Nut	Bronze	1	1
14	Resilient Wedge	Ductile Iron, Coated With EPDM Rubber	1	1
15	Wedge Cover	Polymer	4	4
16	Wedge Cover Pin	Polymer	4	4
17	Hex Head Bolt, 1-3/8-6 x 8-1/2"	Stainless Steel	32	32
18	Hex Nut, 1-3/8-6	Stainless Steel	32	32
20	Pipe Plug, 1/2 NPT	Stainless Steel	4	4
21	Lower Thrust Washer	Delrin	1	1
22	Stud, 1-1/4-7 x 7-1/2"	Stainless Steel	8	8
23	Hex Nut, 1-1/4-7	Stainless Steel	16	16
24	Spur Gear Operator 8:1	Rotork IS12	1	1
25	Square Key, 3/4 x 4-1/2	Hardened Steel	1	1
28	Socket Head Cap Screw 3/4-10 x 2-1/2"	Stainless Steel	8	8
29	Actuator Gasket	Rubber O-ring	1	1
30	Hex Head Bolt, 7/8-9 x 1-1/2"	Plated Steel	1	1
31	Washer	Steel	1	1
50-K	Set Screw 5/16-18 x 3/4"	Stainless Steel	1	1
55	Blind Flange	Ductile Iron	1	1
56	Stud, 5/8-11 x 3"	Stainless Steel	8	8
57	Hex Nut, 5/8-11	Stainless Steel	8	8
83	Blind Flange Gasket	Rubber	2	2

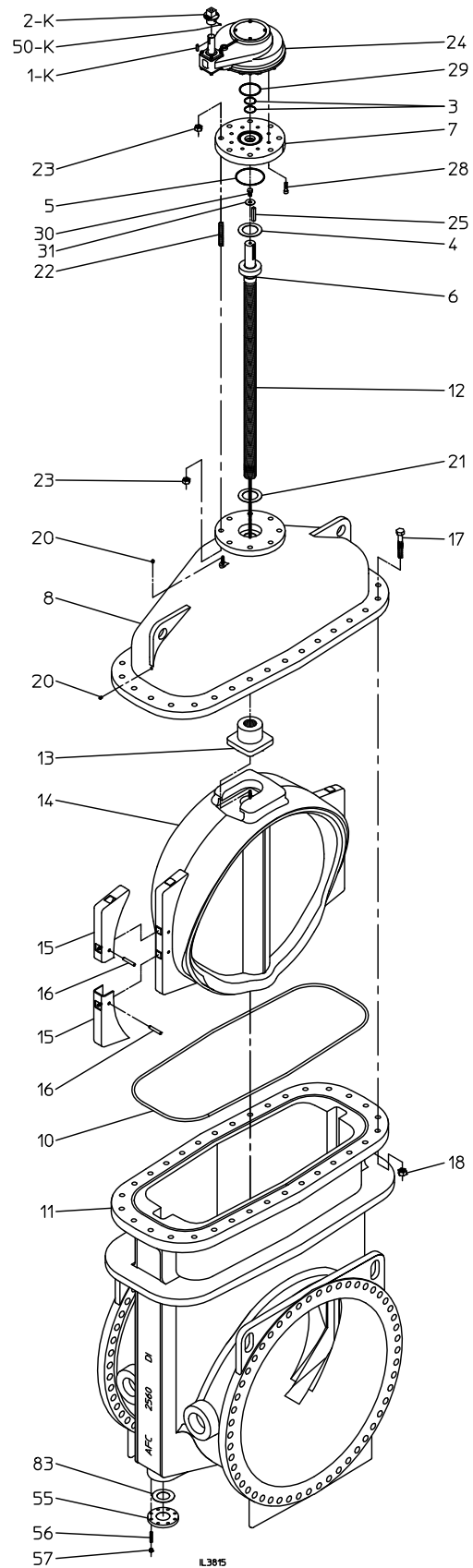



# SERIES 2500 - OS&Y PARTS LIST, 2-1/2" & 3" SIZES

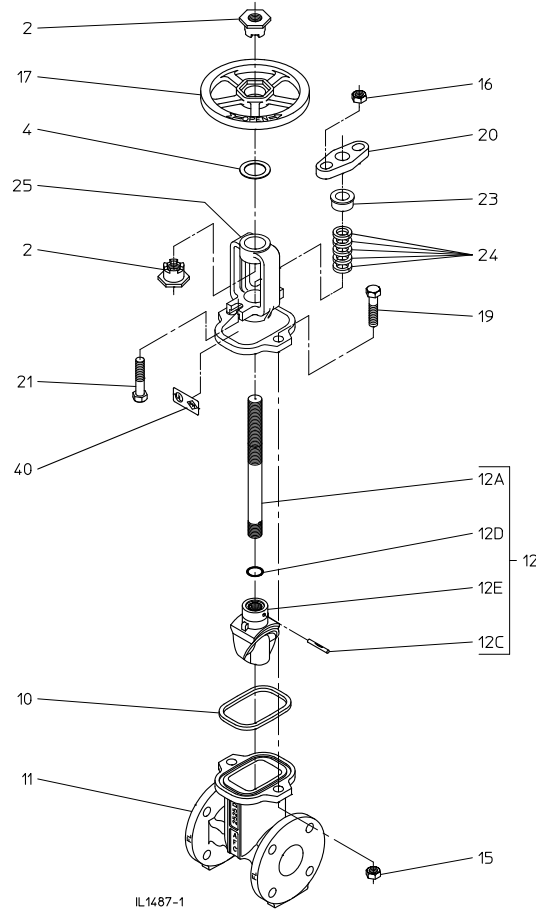

IL1487-1

Reference Number	Description	Material	Qty.	
			Series 2500	
			2-1/2"	3"
2	Stem Nut	Forging Brass	2	2
4	Handwheel Washer	Nylon	1	1
10	Bonnet Gasket	Rubber	1	1
11	Body	Ductile Iron	1	1
12	Stem & Wedge Assembly	See Below	1	1
12A	Stem	Bronze	1	1
		Stainless Steel (Optional)		
12C	Groove Pin	Stainless Steel	1	1
12D	O-ring	Rubber	1	1
12E	Resilient Wedge	Bronze, Coated With EPDM Rubber	1	1
15	Hex Nut, 5/8-11	Stainless Steel	2	2
16	Hex Nut, 5/8-11	Brass	2	2
17	Handwheel	Ductile Iron	1	1
19	Hex Head Bolt, 5/8-11 x 2-1/4"	Stainless Steel	2	2
20	Gland Follower	Ductile Iron	1	1
21	Hex Head Bolt, 5/8-11 x 2-1/2"	Stainless Steel	2	2
23	Gland	Sintered Bronze, Oil Impregnated	1	1
24	Packing Ring	PTFE Impregnated Braided Graphite	5	6
25	Bonnet	Ductile Iron	1	1
40	UL/FM Label	Film	1	1



# SERIES 2500 - OS&Y PARTS LIST, 4" - 8" SIZES



Reference Number	Description	Material	Qty.		
			Series 2500-1		
			4"	6"	8"
2	Stem Nut	Bronze	2	2	2
3	O-ring	Rubber	1	1	1
4	Handwheel Washer	Brass	1	1	1
5	Stuffing Box Gasket	Rubber	1	1	1
8	Bonnet	Ductile Iron	1	1	1
9	Hex Head Bolt, 5/8-11 x 2"	Stainless Steel	6	2	2
10	Bonnet Gasket	Rubber	1	1	1
11	Body	Ductile Iron	1	1	1
12	Stem	Bronze	1	1	1
		Stainless Steel (Optional)			
13	Wedge Nut	Bronze	1	1	1
14	Resilient Wedge	Ductile Iron, Coated With EPDM Rubber	1	1	1
15	Hex Nut, 5/8-11	Stainless Steel	6	8	10
16	Hex Nut, 5/8-11	Brass	2	2	2
17	Handwheel	Ductile Iron	1	1	1
18	Groove Pin	Stainless Steel	1	1	1
19	Hex Head Bolt, 5/8-11 x 2-1/4"	Stainless Steel	-	6	-
20	Gland Follower	Ductile Iron	1	1	1
21	Hex Head Bolt, 5/8-11 x 2-1/2"	Stainless Steel	-	-	8
22	Hex Head Bolt, 5/8-11 x 2-3/4"	Stainless Steel	2	2	2
23	Gland	Sintered Bronze, Oil Impregnated	1	1	1
24	Packing Ring	PTFE Impregnated Braided Graphite	6	6	6
25	Yoke	Ductile Iron	1	1	1
40	UL/FM Label	Pressure Sensitive Acrylic Film	1	1	1
69	Wedge Cover	Polymer	2	2	2

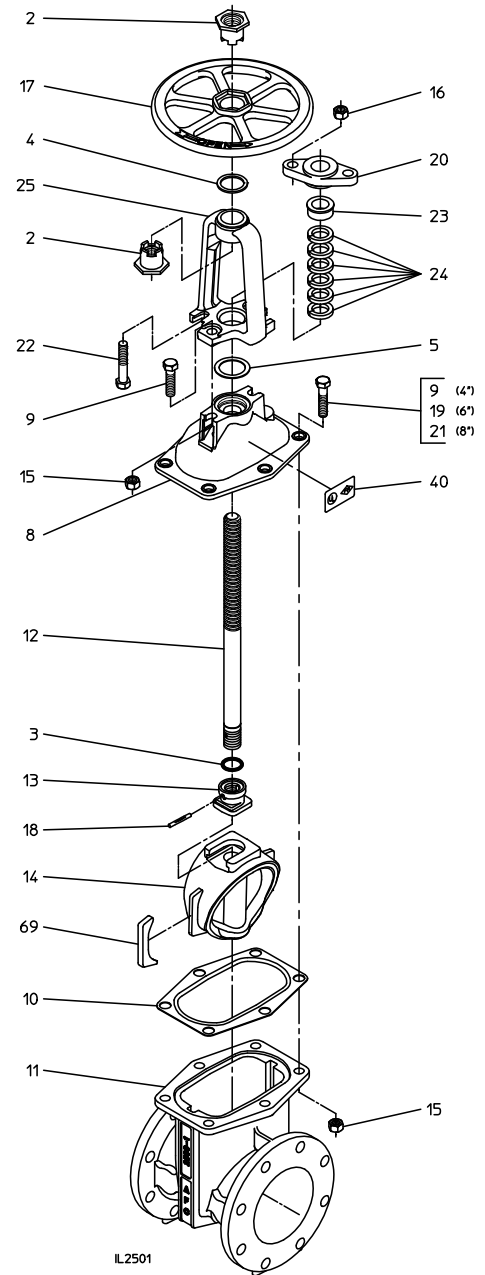

# SERIES 2500 - OS&Y PARTS LIST, 10" & 12" SIZES



Reference Number	Description	Material	Qty.	
			Series 2500-1	
			10"	12"
2	Yoke Nut	Bronze	1	1
4	Handwheel Washer	Brass	1	1
5	Stuffing Box Gasket	Rubber O-ring	1	1
8	Bonnet	Ductile Iron	1	1
9	Hex Head Bolt, 5/8-11 x 2"	Stainless Steel	6	2
10	Bonnet Gasket	Rubber	1	1
11	Body	Ductile Iron	1	1
12	Stem & Wedge Assembly	See Below	1	1
12A	Stem	Bronze	1	1
		Stainless Steel (Optional)		
12B	Wedge Nut	Ductile Iron	1	1
12C	Groove Pin	Stainless Steel	1	1
12D	O-ring	Rubber	1	1
14	Resilient Wedge	Ductile Iron, Coated With EPDM Rubber	1	1
15	Hex Nut, 5/8-11	Stainless Steel	14	4
16	Hex Nut, 5/8-11	Brass	2	2
17	Handwheel	Ductile Iron	1	1
20	Gland Follower	Ductile Iron	1	1
21	Hex Head Bolt, 5/8-11 x 2-1/2"	Stainless Steel	4	4
22	Hex Head Bolt, 5/8-11 x 2-3/4"	Stainless Steel	10	-
23	Gland	Bronze	1	1
24	Packing Ring	PTFE Impregnated Braided Graphite	5	5
25	Yoke	Ductile Iron	1	1
26	Handwheel Nut	Cast Bronze	1	1
27	Hex Head Bolt, 5/8-11 x 4-1/4"	Stainless Steel	2	2
28	Square Key	Stainless Steel	1	1
40	UL/FM Label	Film	1	1
48	Hex Nut, 3/4-10	Stainless Steel	-	10
67	Hex Head Bolt, 3/4-10 x 3"	Stainless Steel	-	10
69	Wedge Cover	Polymer	2	2

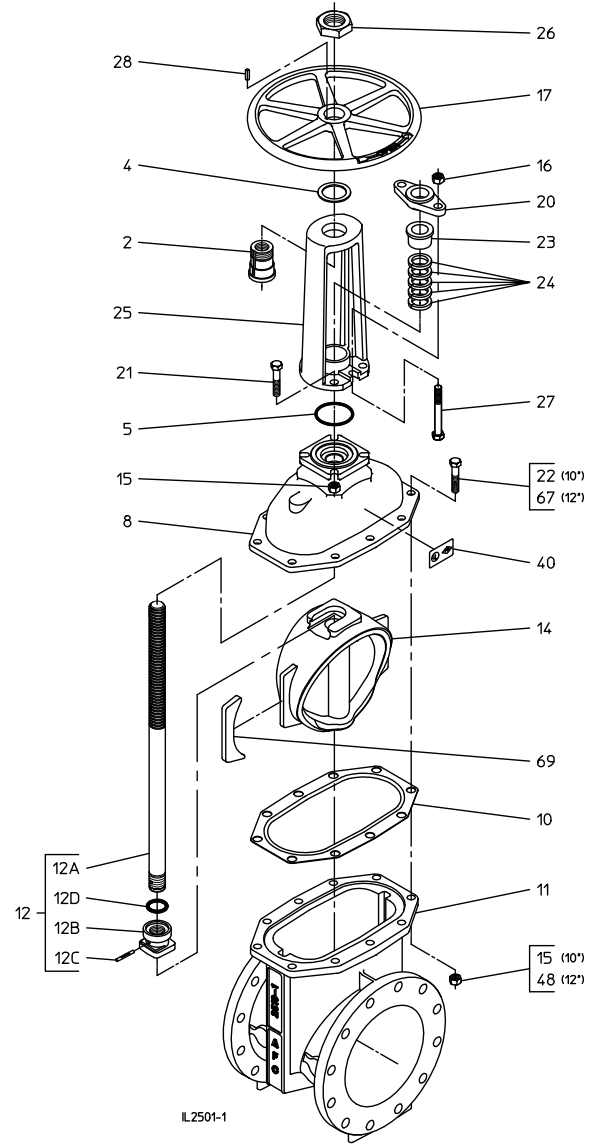

# SERIES 2500 - OS & Y PARTS LIST, 14"-24" SIZES



Ref No.	Description	Material	Qty.				
			Series 2500				
			14"	16"	18"	20"	24"
2	Yoke Nut	Bronze	1	1	1	1	1
4	Handwheel Washer	Brass	1	1	1	1	1
5	Stuffing Box Gasket	Rubber O-ring	1	1	1	1	1
8	Bonnet	Ductile Iron	1	1	1	1	1
10	Bonnet Gasket	Rubber	1	1	1	1	1
11	Body	Ductile Iron	1	1	1	1	1
12	Stem & Wedge Nut Assembly	See Below	1	1	1	1	1
12A	Stem	Stainless Steel	1	1	1	1	1
12B	Wedge Nut	Ductile Iron	1	1	1	1	1
12C	Groove Pin	Stainless Steel	1	1	1	1	1
12D	O-ring	Rubber	1	1	1	1	1
14	Resilient Wedge	Ductile Iron, Coated with EPDM Rubber	1	1	1	1	1
15	Wedge Cover	Polymer	2	2	2	2	2
16	Wedge Cover Pin	Polymer	2	4	4	2	2
17	Hex Head Bolt, 3/4-10 x 3-1/2"	Stainless Steel	14	16	-	-	-
17	Hex Head Bolt, 7/8-9 x 4"	Stainless Steel	-	-	16	-	-
17	Hex Head Bolt, 7/8-9 x 4-1/2"	Stainless Steel	-	-	-	18	-
17	Hex Head Bolt, 7/8-9 x 5"	Stainless Steel	-	-	-	-	20
18	Hex Nut, 3/4-10	Stainless Steel	14	16	-	-	-
18	Hex Nut, 7/8-9	Stainless Steel	-	-	16	18	20
20	Pipe Plug, 3/8 NPT	Stainless Steel	1	1	1	1	1
21	Gland Follower	Ductile Iron	1	1	1	1	1
23	Gland	Bronze	1	1	1	1	1
24	Packing Ring	PTFE Impregnated Braided Graphite	6 to 7	6 to 7	6 to 7	6 to 7	6 to 7
25	Yoke	Ductile Iron	1	1	1	1	1
26	Handwheel Nut	Bronze	1	1	1	1	1
28	Square Key	Stainless Steel	1	1	1	1	1
61	Handwheel	Ductile Iron	1	1	1	1	1
62	Hex Head Bolt 7/8-9 x 3-1/2	Stainless Steel	4	4	4	-	-
62	Hex Head Bolt 7/8-9 x 4	Stainless Steel	-	-	-	4	4
63	Hex Nut	Stainless Steel	4	4	4	4	4
64	Hex Head Bolt 5/8-11 x 3-1/2	Stainless Steel	2	2	2	2	2
65	Hex Nut	Brass	2	2	2	2	2
66	1/4" Zerk Fitting	Stainless Steel	1	1	1	1	1

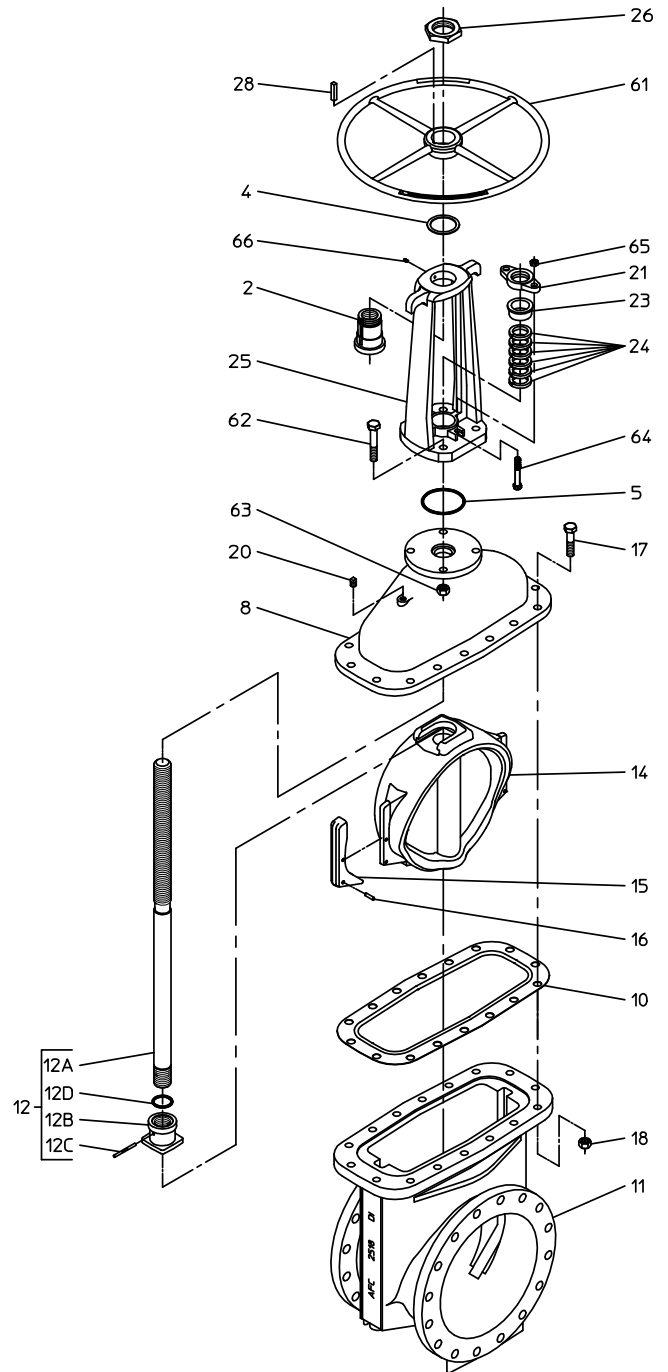

91-21575



## Pressure Test

A key principle of design engineering is the selection of the proper material for an engineered product. Cost and durability are strong factors in selecting the material. Two materials with a long service history in the waterworks industry are gray and ductile iron. These two alloys are similar in chemical analysis but are quite different in mechanical properties. In gray iron, the graphite exists in an interconnected flake structure with the iron. Gray iron will fracture more readily along this continuous graphite iron flake structure. In ductile iron the graphite exists as discrete graphite nodules with more substantial areas of iron in between, forming a more stronger alloy than gray iron. These differences in the microstructure are reflected in the mechanical properties of the two irons. Ductile iron has superior mechanical properties and behaves more like steel in an engineering sense than does gray iron. By observing a few mechanical tests such as those defined in the American Society for Testing Materials (ASTM) E-8 standard test procedures, you can easily see the difference in the superior mechanical properties of ductile iron.

### Tensile Test

Using a common tensile test with specimens of 11/32" diameter, you should see differences in the elongation of gray iron versus ductile iron. It is apparent that ductile has a certain amount of elongation and plasticity before fracture. In contrast, gray iron is a brittle material with plastic elongation so close to zero that it is not reported on a tensile test.

### Charpy V-Notch Test

The Charpy V-Notch Test (ANSI/AWWA C151/A21.51) is another engineering test used to characterize the toughness of a material. The test is an impact test that measures the amount of energy required to fracture a standard 10mm x 10mm notched specimen. The greater the energy requirements, the tougher the material. Charpy tests are not routinely performed on gray iron as the results are always near zero, which indicates very low resistance to cracking. Ductile iron Charpy impact values range from 5 to 15 ft-lbs. The real value of ductile iron is its toughness and resistance to rough handling.

After considering the mechanical properties of a particular material, our design engineers are able to apply design rules to determine the section thickness and reinforcing scheme to meet the intended service conditions. AMERICAN engineers have used the superior mechanical properties of ductile iron to design a more rugged valve than required under the ANSI/AWWA C-509 standard. To demonstrate this point we tested 2 12 in. AMERICAN Flow Control gate valves - one made of gray iron and one made of ductile iron, to see how the mechanical properties we have discussed apply to the effectiveness of a completed product.

The predecessor to the Series 2500 gate valve was the Series 500 gate valve. A test comparison of the two valves found significant differences in the performance of the valve designs. The 12 in. Series 500 gray iron resilient wedge gate valve is manufactured according to ANSI/AWWA C-509 Resilient Seated Gate Valve Standard. The valve is rated at 200 psig and has a safety factor to withstand significant pressure surges. This pressure test results in fracture of the bonnet flange at a pressure of 850 psig.

The 12 in. Series 2500 Ductile Iron resilient wedge gate valve is manufactured to conform to the requirements of the new reduced wall resilient wedge gate valve standard ANSI/AWWA C-515. It is rated at 250 psig with sufficient safety factor to withstand significant pressure surges. Pressure testing of the valve shell to failure generally results in "dishing" of the bonnet and body flange connection such that the bonnet gasket is blown out past the flange. The test case blew the bonnet gasket at 1500 psig without failure due to fracture of the shell. Although lighter in weight, the ductile iron valve is a more rugged design with the ability to withstand abuse during installation and possible extreme surge pressures.

### Beam Load Test

Flanged end valve and piping components are not designed to bear a substantial beam load. We recommend that valve installations be executed in such a way that all beam loads on flanged components be eliminated. Unfortunately, settling of structures, slight misalignment, vibration, etc. can often result in induced beam loads, thus placing undue stress on flanged systems. To simulate an induced beam load, we connected two lengths of flanged ductile iron pipe to a 12 in. flange x flange gray iron valve with the valve closed and one end of the piping system pressurized to 100 psig. A vertical press was used to apply the load to the valve bonnet while supporting the ends of the pipe. This resulted in both hydrostatic and beam loads on the flanges of the valve and piping system. The vertical load on the valve was increased until the flange fractured. Failure occurred by fracture of the pipe flange at a beam load of 78,000 ft-lbs with a vertical deflection of 7/8 in.

Similar testing was performed on a 12 in. flange by flange reduced wall ductile iron valve with the valve closed and one end of the piping system pressurized to 100 psig. The vertical load was applied incrementally until fracture. Failure occurred by fracture of the pipe flange at a beam load of 135,000 ft-lbs. with a vertical displacement of 2 inches.

Gray iron or ductile iron? Ductile iron has the strength, durability and reliability to meet and exceed the requirements of the waterworks industry. Our ductile iron valves have the ability to resist high stress from internal and external loads.

## SERIES 2500 - WEIGHTS



### NRS Valve - Series 2500

End Connections	Valve Size													
	2-1/2"	3"	14"	16"	18"	20"	24"	30"	36"	42"	48"	54"	60"	66"
MJ x MJ	-	44	688	869	1162	1543	2356	4551	7469	11479	15880	-	-	-
FL x MJ (Class 125)	-	48	735	899	1151	1525	2248	4528	7388	11350	15925	-	-	-
FL x FL (Class 125)	46	52	735	909	1147	1509	2245	4448	7329	11320	15980	17084	27839	29549
FL x FL (Class 250)	-	68	968	1110	1437	1896	2919	5214	8418	12491	17787	-	-	-
TY x TY	-	-	-	-	-	-	-	-	-	-	-	-	-	-
FL x TY (Class 125)	-	-	-	-	-	-	-	-	-	-	-	-	-	-
PO x PO	-	-	691	898	-	-	-	-	-	-	-	-	-	-
PVC x PVC	41	47	-	-	-	-	-	-	-	-	-	-	-	-
Threaded x Threaded (Screw x Screw)	36	41	-	-	-	-	-	-	-	-	-	-	-	-
FL x MJ (Tapping)	-	-	755	925	1186	1596	2299	4506	7408	11364	15937	-	-	-
FX x FX (Flex-Ring)	-	-	-	987	-	1659	2473	4820	7621	11526	17381	-	-	-

### NRS Valve - Series 2500-1

End Connections	Valve Size					
	Series 2500-1					
	2"	4"	6"	8"	10"	12"
MJ x MJ	17	58	97	147	230	333
FL x MJ (Class 125)	-	64	103	162	248	366
FL x FL (Class 125)	22	72	109	177	270	402
FL x FL (Class 250)	-	94	163	251	380	551
TY x TY	-	70	111	177	265	372
FL x TY (Class 125)	-	70	110	176	266	386
PO x PO	-	-	-	-	-	-
PVC x PVC	16	59	112	159	-	-
Threaded x Threaded (Screw x Screw)	13	-	-	-	-	-
FL x MJ (Tapping)	-	68	109	169	261	380
FX x FX (Flex-Ring)	-	-	118	-	-	-
AA x AA (ALPHA™)	-	72	112	190	274	382
AX x AX (ALPHA™ XL)	-	78	118	202	288	409
FL (Class 125) x AA (ALPHA™)	-	73	115	187	276	401
MJ x AA (ALPHA™)	-	-	107	-	-	-

### OS & Y Valve - Series 2500 and 2500-1

End Connections	Series 2500 / Series 2500-1												
	2"	2-1/2"	3"	4"	6"	8"	10"	12"	14"	16"	18"	20"	24"
FL x FL (Class 125)	28	47	53	90	132	207	313	446	847	979	1250	1678	2386
FL x FL (Class 250)	-	-	69	112	185	282	427	600	976	1181	1540	2007	2951

**NOTE: All weights are in pounds**

ALPHA™ is a trademark of Romac Industries, Inc. (U.S. Patent 8,894,100)

# AMERICAN Flow Control

## SERIES 2500 DUCTILE IRON RESILIENT WEDGE GATE VALVE



### SUBMITTAL SHEET

Qty	2"	2-1/2"	3"	4"	6"	8"	10"	12"	14"	16"	18"	20"	24"	30"	36"	42"	48"	54"	60"	66"	
<b>Actuator (Check One)</b>	<input type="checkbox"/> NRS with 2" Sq. Operating Nut <input type="checkbox"/> NRS with Handwheel <b>3" - 12" Valves Only</b> <input type="checkbox"/> NRS with Enclosed Miter Gearing  <b>14" - 66 Valves Only</b> <input type="checkbox"/> NRS with Bevel Gears <input type="checkbox"/> NRS with Spur Gears  <input type="checkbox"/> OS & Y with Handwheel (2" - 24" Valves Only)																				
	<input type="checkbox"/> NRS with T-Head Operating Nut <input type="checkbox"/> Post Indicator Valve (PIV) <b>Also Specify</b> <input type="checkbox"/> 2" Sq. Operating Nut Parallel to Waterway <input type="checkbox"/> 2" Sq. Operating Nut Perpendicular to Waterway <input type="checkbox"/> Handwheel Perpendicular to Waterway  <b>Also Specify</b> <input type="checkbox"/> 2" Sq. Oper. Nut <input type="checkbox"/> Handwheel																				
<b>Open Direction:</b> <input type="checkbox"/> Left (CCW) <input type="checkbox"/> Right (CW)										<input type="checkbox"/> Optional Stainless Steel Stems											
<b>End Connections:</b>																					
<b>Mechanical Joint Accessories</b> <input type="checkbox"/> Yes <input type="checkbox"/> No																					
<b>UL Listed, FM Approved:</b> <input type="checkbox"/> Yes <input type="checkbox"/> No																					
<b>Other Requirements (List on a Separate Sheet):</b>																					

Available Configurations	Series 2500 / Series 2500-1																				
	2"	2-1/2"	3"	4"	6"	8"	10"	12"	14"	16"	18"	20"	24"	30"	36"	42"	48"	54"	60"	66"	
<b>ACTUATORS</b>																					
NRS with 2" Sq. Operating Nut	X	X	X	X	X	X	X	X	X	X	X	X	X	N/A	N/A	N/A	N/A	N/A	N/A	N/A	
NRS with T-Head Operating Nut	X	X	N/A	N/A	N/A	N/A	N/A	N/A	N/A	N/A	N/A	N/A	N/A	N/A	N/A	N/A	N/A	N/A	N/A	N/A	
NRS with Handwheel	X	X	X	X	X	X	X	X	X	X	X	X	X	N/A	N/A	N/A	N/A	N/A	N/A	N/A	
Post Indicator Valve (PIV)	N/A	X	X	X	X	X	X	X	X	X	X	X	X	N/A	N/A	N/A	N/A	N/A	N/A	N/A	
NRS with Enclosed Miter Gearing	N/A	N/A	X	X	X	X	X	X	N/A	N/A	N/A	N/A	N/A	N/A	N/A	N/A	N/A	N/A	N/A	N/A	
NRS with Bevel Gears	N/A	N/A	N/A	N/A	N/A	N/A	N/A	N/A	X	X	X	X	X	X	X	X	X	X	X	X	
NRS with Spur Gears	N/A	N/A	N/A	N/A	N/A	N/A	N/A	N/A	X	X	X	X	X	X	X	X	X	X	X	X	
OS & Y	X	X	X	X	X	X	X	X	X	X	X	X	X	N/A	N/A	N/A	N/A	N/A	N/A	N/A	
<b>END CONNECTIONS</b>																					
Mech Joint x Mech Joint (MJ x MJ)	X	N/A	X	X	X	X	X	X	X	X	X	X	X	X	X	X	X	N/A	N/A	N/A	
Flange x Flange, Class 125 (FL x FL, 125)	X	X	X	X	X	X	X	X	X	X	X	X	X	X	X	X	X	X	X	X	
Flange x Flange, Class 250 (FL x FL, 250)	N/A	N/A	X	X	X	X	X	X	X	X	X	X	X	X	X	X	X	N/A	N/A	N/A	
TYTON® x TYTON® (TY x TY)	N/A	N/A	N/A	X	X	X	X	X	Order Push-On Ends												
Push On x Push On (PO x PO)									X	X	N/A	N/A	N/A	N/A	N/A	N/A	N/A	N/A	N/A	N/A	N/A
PVC x PVC (PVC x PVC)	X	X	X	X	X	X	N/A	N/A	N/A	N/A	N/A	N/A	N/A	N/A	N/A	N/A	N/A	N/A	N/A	N/A	
Threaded x Threaded (THD x THD)	X	X	X	N/A	N/A	N/A	N/A	N/A	N/A	N/A	N/A	N/A	N/A	N/A	N/A	N/A	N/A	N/A	N/A	N/A	
Flange, Class 125 x Mech Joint (FL x MJ)	N/A	N/A	X	X	X	X	X	X	X	X	X	X	X	X	X	X	X	N/A	N/A	N/A	
Flange, Class 125 x TYTON® (FL x TY)	N/A	N/A	N/A	X	X	X	X	X	N/A	N/A	N/A	N/A	N/A	N/A	N/A	N/A	N/A	N/A	N/A	N/A	
Flex-Ring® x Flex-Ring® (FX x FX)	N/A	N/A	N/A	N/A	X	N/A	N/A	N/A	N/A	X	N/A	X	X	X	X	X	X	N/A	N/A	N/A	
ALPHA™ x ALPHA™ (AA x AA)	N/A	N/A	N/A	X	X	X	X	X	N/A	N/A	N/A	N/A	N/A	N/A	N/A	N/A	N/A	N/A	N/A	N/A	
ALPHA™ XL x ALPHA™ XL (AX x AX)	N/A	N/A	N/A	X	X	X	X	X	N/A	N/A	N/A	N/A	N/A	N/A	N/A	N/A	N/A	N/A	N/A	N/A	
Flange, Class 125 x ALPHA™ (FL, 125 x AA)	N/A	N/A	N/A	X	X	X	X	X	N/A	N/A	N/A	N/A	N/A	N/A	N/A	N/A	N/A	N/A	N/A	N/A	
Mech Joint x ALPHA™ (MJ x AA)	N/A	N/A	N/A	N/A	X	N/A	N/A	N/A	N/A	N/A	N/A	N/A	N/A	N/A	N/A	N/A	N/A	N/A	N/A	N/A	

KEY:    X = Available    N/A = Not Available

**NOTES:**

1.    3 in.–54 in. valves meet or exceed requirements of ANSI/AWWA C515 with 250 psig rated working pressure.
2.    2-, 2-1/2-, 42-, 48-, 54-, 60- and 66-in. valves have 250 psig rated working pressure but are not included in ANSI/AWWA C515.
3.    2 in. - 66 in. valves are Certified to NSF/ANSI Standard 61 and NSF/ANSI 372.
4.    Fusion bonded epoxy coating meets or exceeds requirements of ANSI/AWWA C550.
5.    See separate submittal sheet for tapping valves.
6.    2 in.–24 in. valves may be ordered in configurations that are UL Listed and Approved by FM Approvals.
7.    TYTON® is a registered trademark of United States Pipe and Foundry Co., LLC.
8.    ALPHA™ is a trademark of Romac Industries, Inc. (U.S. Patent 8,894,100)



## Storage

Valves are palletized when shipped, which provides suitable protection from weather and sunlight during storage. If palletizing is disbanded and valves removed, remaining valves should be suitably covered or stored elsewhere with the valve stem vertical.

- Always store valves fully closed.
- When possible, keep valves out of the weather.
- In cold climates, keep the inside of the valve drained of any water to prevent freezing.
- Whenever possible, cover valves with a waterproof covering.
- Protect all parts of the valve at all times

## Inspection Before Installation

- Check to make sure that the valve end connections are clean and that the valve is not damaged.
- Check opening direction and other details against specification.
- Open and close the valve to make sure it works properly.
- Clean the inside of the valve to remove all contaminants that may affect water system purity.

Keep the valve closed when placing in trench.

## Installation

1. Handle the valve carefully.
2. **Check all bolts for tightness.** Gaskets may shrink during storage and might leak if the bolts are not retightened.
3. Prepare pipe ends in accordance with pipe manufacturer's instructions.
4. Install the valve as per appropriate instructions for the specified joint (flanged, mechanical joint, PVC, etc.)

**NOTE: Only use 1/8" thick rubber "ring" type gaskets Do not use composition or flat full-face gaskets.**

5. **Be sure that the water main is properly supported to avoid line stress on the valve. Make sure the valve is properly supported and that no stress is transferred to the adjoining pipeline. Due to the exponential increase in the weight of larger size valves, proper installation bedding and support is essential. Failure to make provisions for the weight of the valve can result in design and/or installation failure.**
6. In buried applications, make sure that the valve box does not transmit traffic loads or other stress to the valve.
7. Do not use valves to force a pipeline into position. Do not deflect any valve/pipe joint.

## Reference Material

These reference materials are available and should be helpful in the installation and testing of gate valve products.

ANSI/AWWA C515	Reduced-Wall, Resilient-Seated Gate Valves
ANSI/AWWA C500	Metal-Seated Gate Valves - 3" - 48"
ANSI/AWWA C600	Installation of Ductile-Iron Water Mains
ANSI/AWWA M23	PVC Pipe - Design and Installation.

All installation, operation and maintenance instructions issued by the manufacturer of the pipe and the valves.

Valve user guides as published by MSS.

NFPA-24 Private Fire Service Mains and Their Appurtenances

These industry practices have been listed to help you make a safe and acceptable installation of a gate valve.

## Testing Procedure

1. Check to see that all valve joints and pressure containing bolting are tight.
2. Valves should never be tested beyond the rated working pressure.
3. After testing, steps should be taken to relieve any trapped pressure in the body of the valve.



# SERIES 2500 - CLASS 125 FLANGED VALVE INSTALLATION, 4" - 12" SIZES

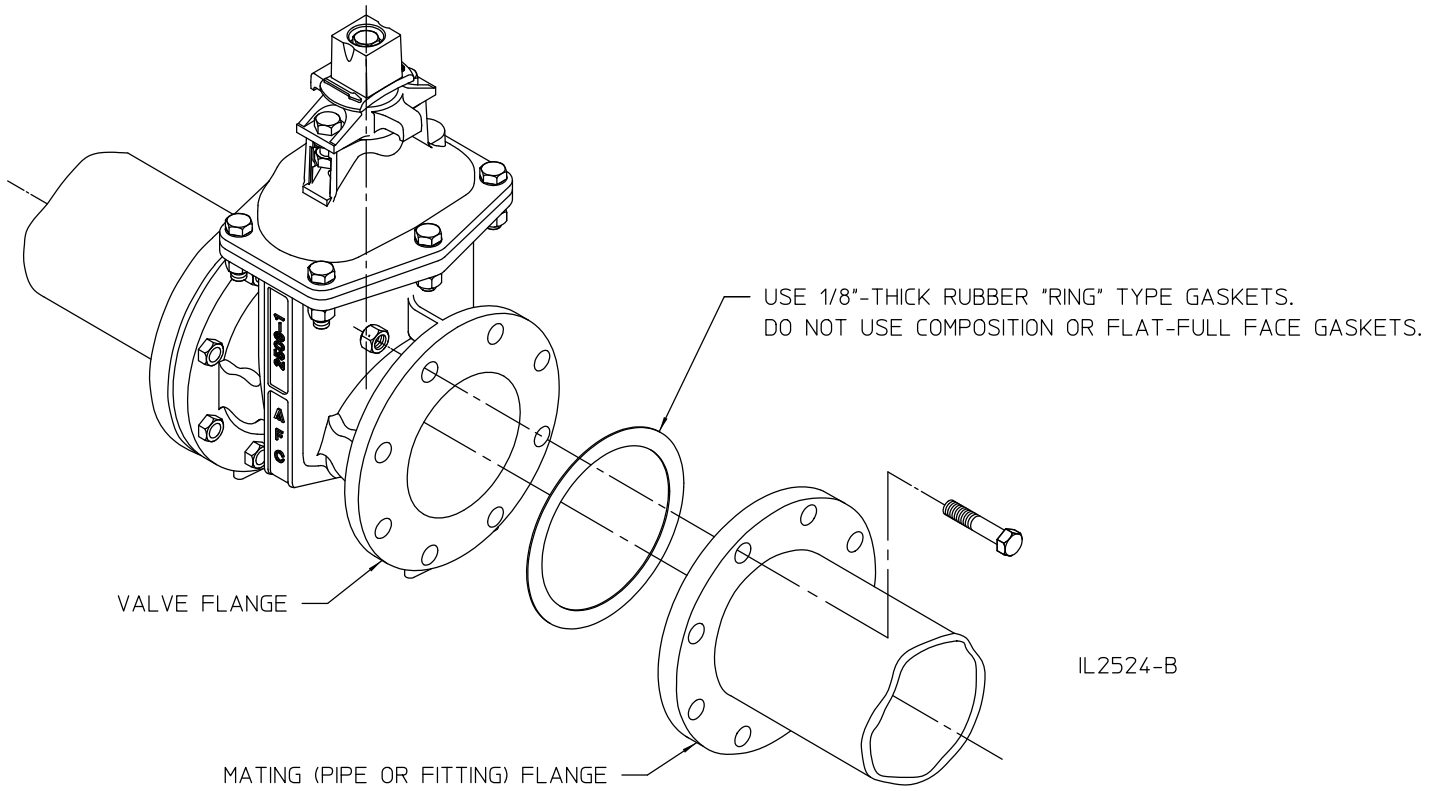



# ALPHA™ Restraint Joint Installation Instructions



Read installation instructions first before installing. Check parts to ensure that no damage has occurred during transit and that no parts are missing.

ALPHA restraint joints will accommodate the following pipe types and sizes:

### ALPHA

- Ductile iron per AWWA C151
- PVC per ASTM D1785 (Schedule 40 and 80)
- PVC per ASTM D2241 (SDR 21)
- PVC per AWWA C900
- HDPE per AWWA C906 (SDR 9, 11, 13.5, and 17)

### ALPHA XL

- Gray iron (Class A, B, C, and D)

Nominal Size (in)	Distance From the End of Pipe (inches)	
	ALPHA	ALPHA XL
4	3.50	4.25
6	3.75	4.00
8	5.00	5.50
10	5.13	5.63
12	5.38	6.00

Nominal Size (in)	ALPHA OD Range (in)	ALPHA XL OD Range (in)
4	4.50 - 4.90	4.80 - 5.10
6	6.60 - 7.00	6.90 - 7.10
8	8.60 - 9.10	9.05 - 9.40
10	10.75 - 11.20	11.10 - 11.45
12	12.75 - 13.30	13.20 - 13.60

1. Compare diameter of pipe with those listed above to ensure that the correct size joint has been selected.
2. Remove any scale or debris that could interfere with the grippers' engagement with the pipe. Clean the pipe surface wherever the gasket will come in contact with the pipe, and check to see that the pipe surface is smooth (no depressions, projections, gouges, etc.) where the gaskets seal against the pipe. Also verify that the pipe is round within the OD limits described in step 1 and that the pipe cut is square.
3. Mark the OD of the pipe as a means of verifying full insertion in the joint. The pipe should be marked at the following locations as measured from the end of the pipe.

4. Lubricate the gasket and pipe surface with a suitable gasket lubricant.
5. With the nut unthreaded to the end of the bolt and the end ring rotated as far counterclockwise as possible, insert pipe into the ALPHA socket until it contacts the pipe stop. The mark applied to the pipe OD in step 3 should be aligned with the edge of the pipe socket.

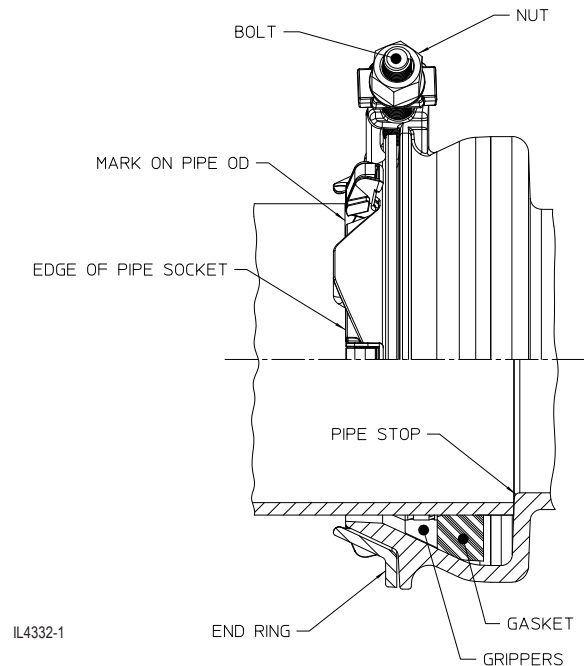

IL4332-1

- Set the desired pipe deflection angle (4° maximum). ALPHA XL installations on pipe at the top of the OD range may have limited deflection (2° maximum).

Note: Do not deflect pipe joint after installation.

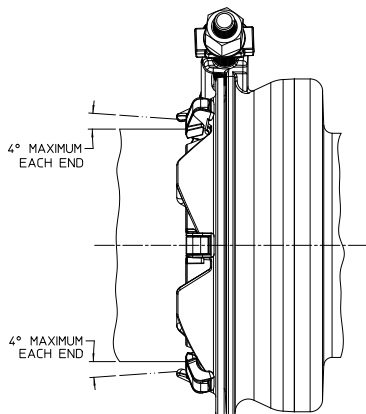

- Tighten nut until the gasket contacts the pipe and the pipe is snugly held in place. This should happen after applying approximately 10-15 ft-lbs of torque.
- Tighten the nut to the torque value shown in the table below and confirm that the grippers are contacting the pipe.

Nominal Size (in)	Torque (ft-lbs)
4	30
6	30
8	45
10	45
12	45

**Note: Do not overtorque or retighten. If a good seal is not achieved after tightening nut to the torque value shown in the table above, check condition of pipe (Step 2), verify maximum pipe deflection is not exceeded (Step 6), and ensure pipe is fully inserted into the socket and contacting the pipe stop.**

- Confirm proper installation by pressurizing the line and checking for leaks.
- Backfill and compact carefully around the pipe and joint.



## PRECAUTIONS

- Make sure no foreign material is trapped between the gasket and pipe, between the grippers, or in the end ring mechanism.
- Carefully inspect gasket for damage and ensure that the cut end of the pipe has been sufficiently deburred to prevent damage to the gasket during installation.
- Keep bolt threads free of debris to allow proper tightening.
- To ensure proper nut tightening, use of a torque wrench with a 1-1/16-inch deep-well socket is recommended. Do not overtorque. Do not use an impact wrench.
- Do not strike or pry on the joint with hammers, shovels, or other equipment.
- Operating pressure shall not exceed whichever is lower; the rated working pressure of the pipe, or that of the adjoining valve or hydrant.
- When used with HDPE pipe, application shall be limited to service with water temperature between 32° F and 85° F.
- For cold weather conditions (below 40° F), performance can be improved by warming the joint and gasket.
- Per ANSI/AWWA C605, which governs the installation of PVC pipe, the factory bevel on PVC pipe may need to be removed or shortened to ensure gasket contact when used with fittings, valves, hydrant and other appurtenances.
- The use of ALPHA restraint joints on valves and fire hydrants shall be limited to buried (non-exposed) applications.
- ALPHA is not intended for use on the plain end of a fitting, or other similarly hard material.



**WARNING: Special care should be taken in the installation, inspection and repair of pressure containing devices such as valves and hydrants. FAILURE TO FOLLOW PROPER PRACTICE AND GUIDELINES CAN RESULT IN SERIOUS INJURY OR DEATH. Do not make repairs while valve is under pressure.**

## Operation

1. Direction of opening is normally indicated by an arrow cast on the handwheel or wrench nut of the valve.
2. Operate gate valves from full closed to full open position and back before applying pressure.
3. Close gate valve slowly against pressure to avoid damage from surge or water hammer.
4. Valves installed on liquid service subject to freezing conditions should be protected to prevent trapping of liquid in the bonnet cavity, expansion on freezing and subsequent damage. The same is true of valves that are subject to considerable temperature increases. Trapped pressure should be vented back to the upstream side to prevent buildup of pressure in the valve bonnet due to high temperature expansion.
5. Valves should be opened and closed without the use of excessive torque applied to the handwheel or wrench nut. Excessive torque may damage the valve.
6. Gate valves are designed for open and close service. Their multi-turn design is not intended for throttling. As such, the valve should never be left in a partial open or closed position for extended periods.

## Maintenance

1. Operate valves at regular intervals. The necessary length of time between the operation of the valve depends upon the time the valve has been in service and the service conditions, but more specifically whatever time period is found to be satisfactory based on local experience. Operation should occur as a minimum of once per year, but in general as detailed in Section A.6, of Appendix A, of ANSI/AWWA C515.
2. Should disassembly or operation require additional lubrication, use an AMERICAN Flow Control recommended food grade grease for the stem threads and thrust collar.
3. Chipped spots in the epoxy coating should be repaired with a liquid two-part epoxy.

## Spare Parts

Under most conditions, the only spare parts needed for the valve would be upper and lower stem O-rings. Under rigorous service, stems, wedges, upper and lower stem O-rings and thrust washers should be carried as spare parts.

Use parts list drawings as a guide for disassembly and ordering repair parts. Also refer to disassembly/reassembly instructions.

## Typical Operating Torque At Rated Working Pressure

Valve Size	Closing Torque Ft-lbs	Opening Torque Ft-lbs
2"	15-20	15-20
2-1/2"	15-20	15-20
3"	30-40	30-40
4"	30-40	30-40
6"	50-60	50-80
8"	70-80	60-90
10"	90-100	125-150
12"	100-125	140-175
14"	Contact Factory	
16"	Contact Factory	
18"	Contact Factory	
20"	Contact Factory	
24"	Contact Factory	
30"	Contact Factory	
36"	Contact Factory	
42"	Contact Factory	
48"	Contact Factory	
54"	Contact Factory	
60"	Contact Factory	
66"	Contact Factory	

## SERIES 2500 - TROUBLESHOOTING GUIDE



Problem	Solution																																																												
Leakage	<p><b>Depending on the location of the leakage, the following should be examined.</b></p> <ol style="list-style-type: none"> <li>1. SEAT: Foreign material may be stuck under the valve wedge. Open valve only enough to get high velocity flow to flush out valve. Repeat several times until leak stops. If this does not solve the problem, it is then necessary to open the valve and check for damage to the rubber encapsulated wedge. If it is damaged or severely cut, replace the wedge.</li> <li>2. STEM: The stem seals are of the O-ring type and the valve has a thrust collar (electric actuated valves normally do not have thrust collars). Always relieve pressure before working on any valve. Check all O-ring seals for leakage and replace as necessary. On OS&amp;Y valves leakage can be stopped by evenly tightening the packing gland bolts. If leakage cannot be stopped, the valve should be repacked.</li> <li>3. BODY: Check for cracked or damaged valve body or bonnet. If damage has occurred, contact manufacturer for further instructions.</li> <li>4. BOLTED CONNECTIONS: Check for loose bonnet-to-body bolts, stuffing box bolts or end joint bolts and tighten as necessary. This should be done prior to pressurization of the line. If line is pressurized, pressure should be relieved prior to tightening any bolts. Do not tighten bolts past the yield strength of the bolt. Reinstall all bolts and nuts and tighten alternately to 70-90 ft-lbs of torque.</li> </ol>																																																												
Valve is Hard to Operate or Is Inoperable	<ol style="list-style-type: none"> <li>1. A valve can become inoperable or hard to operate during testing of the pipeline. Prior to relieving pipeline pressure, the valve should be opened to relieve any trapped pressure.</li> <li>2. The application of excessive torque on a valve can cause permanent damage to the operating parts. A common source of excessive torque is from the use of portable power actuators. Output torques generated by these machines should be adjusted to be suitable for the valve size. The last or first turns of operation should be done by hand.</li> </ol> <p style="text-align: center;"><b>Number of Turns to Open/Close</b></p> <table border="1" style="width: 100%; text-align: center; border-collapse: collapse;"> <thead> <tr> <th colspan="20" style="font-size: small;">Series 2500 / Series 2500-1</th> </tr> <tr> <th>2"</th><th>2-1/2"</th><th>3"</th><th>4"</th><th>6"</th><th>8"</th><th>10"</th><th>12"</th><th>14"</th><th>16"</th><th>18"</th><th>20"</th><th>24"</th><th>30"</th><th>36"</th><th>42"</th><th>48"</th><th>54"</th><th>60"</th><th>66"</th> </tr> </thead> <tbody> <tr> <td>9</td><td>11</td><td>13</td><td>14</td><td>20</td><td>26</td><td>32</td><td>38</td><td>44</td><td>50</td><td>56</td><td>62</td><td>76</td><td>379</td><td>448</td><td>694</td><td>789</td><td>789</td><td>984</td><td>984</td> </tr> </tbody> </table> <p>Note: 24" and smaller reflect non-geared valves. 30" and larger reflect geared valves</p> <ol style="list-style-type: none"> <li>3. If valve has not been operated periodically, excessive buildup could occur that would affect valve operation. The valve should be exercised one turn at a time and cycled from open to closed as necessary to attempt removal of internal buildup.</li> </ol>	Series 2500 / Series 2500-1																				2"	2-1/2"	3"	4"	6"	8"	10"	12"	14"	16"	18"	20"	24"	30"	36"	42"	48"	54"	60"	66"	9	11	13	14	20	26	32	38	44	50	56	62	76	379	448	694	789	789	984	984
Series 2500 / Series 2500-1																																																													
2"	2-1/2"	3"	4"	6"	8"	10"	12"	14"	16"	18"	20"	24"	30"	36"	42"	48"	54"	60"	66"																																										
9	11	13	14	20	26	32	38	44	50	56	62	76	379	448	694	789	789	984	984																																										
Valve Leaks During Testing	<ol style="list-style-type: none"> <li>1. Resilient seated gate valves per ANSI/AWWA C515 have a zero allowable leakage rate. If a leak is detected while testing, it is necessary to find the cause.</li> <li>2. If seat leakage is detected, it may be due to foreign material or trapped air in the line. Open the valve enough to get high velocity flow to flush out valve. Repeat several times until leakage stops.</li> <li>3. If testing between valves, allow enough time to fill the valve and vent off air.</li> </ol>																																																												



**WARNING: Special care should be taken in the installation, inspection and repair of pressure containing devices such as valves and hydrants. FAILURE TO FOLLOW PROPER PRACTICE AND GUIDELINES CAN RESULT IN SERIOUS INJURY OR DEATH. Do not make repairs while valve is under pressure.**

### Disassembly

1. Remove bolts and nuts that attach operating nut and stuffing box.
2. Remove operating nut and stuffing box.
3. Back stem out of bonnet by turning in the closing direction.
4. Inspect O-rings and, if damaged, remove from stuffing box and stem. Replace with new O-rings and lubricate with food grade grease.
5. Inspect thrust washers and stuffing box gasket (O-ring) and replace if damaged.
6. Remove bolts and nuts that attach bonnet to valve body. Remove bonnet to inspect bonnet gasket, wedge and interior of valve body. Replace parts if damaged.

### Reassembly

Reassembly is the reverse of disassembly while paying attention to the following points.

1. Make sure the bonnet gasket is positioned correctly on the valve body flange when bonnet is assembled onto valve body.
2. Lubricate stem threads with an AMERICAN Flow Control recommended food grade grease before installing into bonnet and threading into wedge nut. Turn stem in opening direction.
3. Position stuffing box gasket in top of bonnet and slide stuffing box onto stem being careful not to cut the stem seal O-rings.
4. Reinstall all bolts and nuts and tighten alternately to 70-90 ft-lb of torque.

# SERIES 2500 - STANDARD NRS REPAIRS, 2"

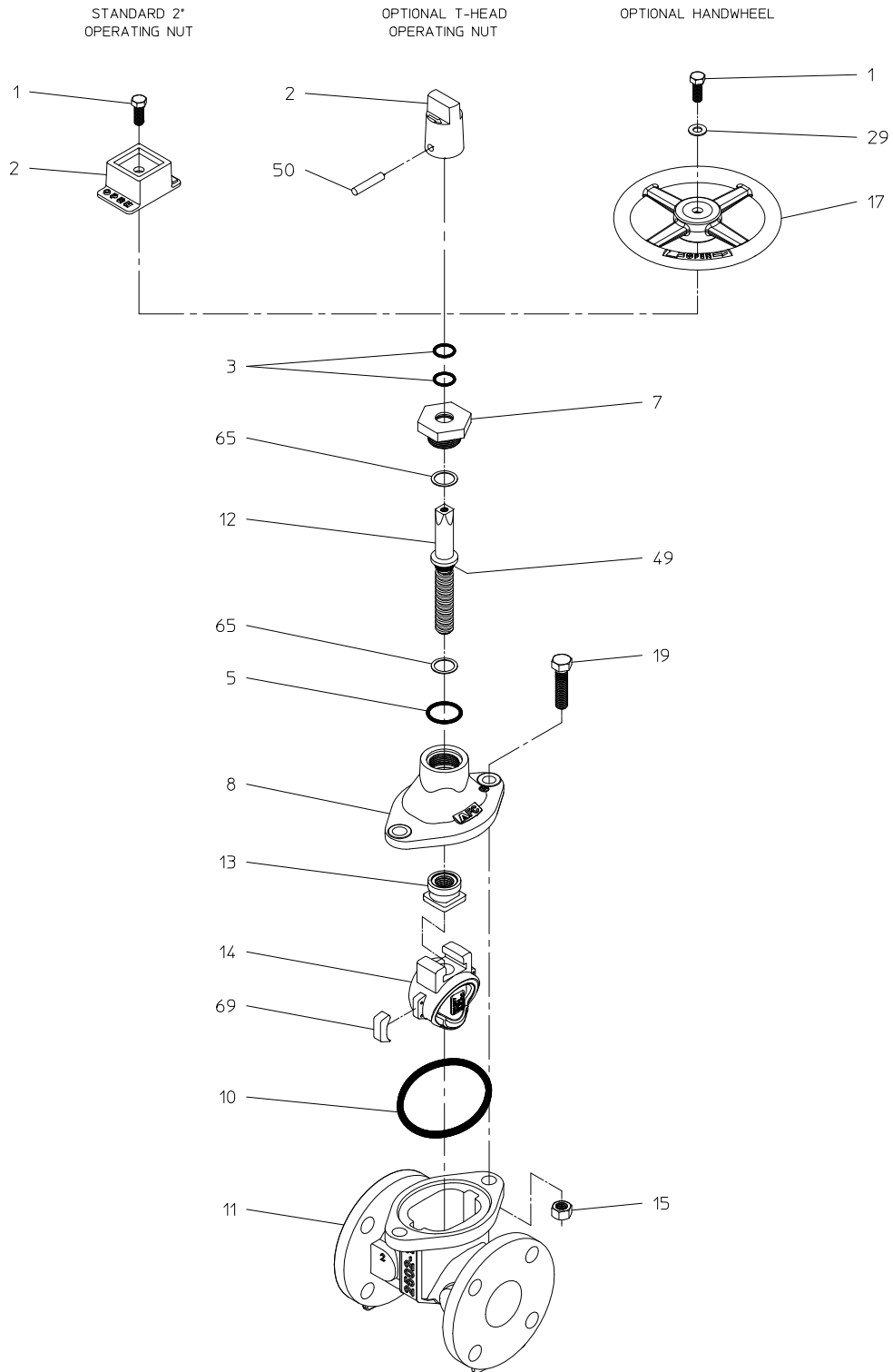

IL 4182

# SERIES 2500 - STANDARD NRS REPAIRS, 2-1/2" & 3"

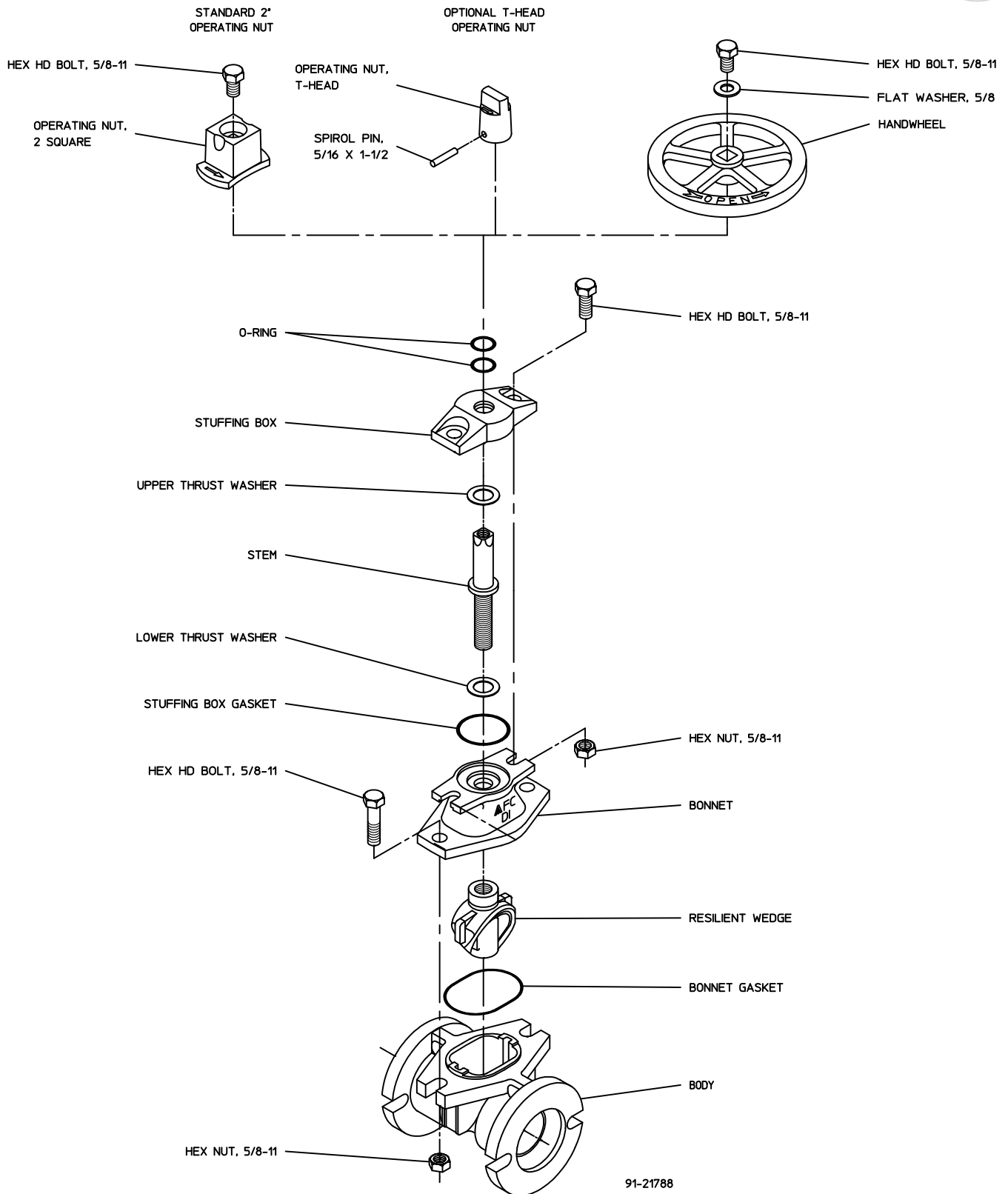



**WARNING: Special care should be taken in the installation, inspection and repair of pressure containing devices such as valves and hydrants. FAILURE TO FOLLOW PROPER PRACTICE AND GUIDELINES CAN RESULT IN SERIOUS INJURY OR DEATH. Do not make repairs while valve is under pressure.**

### Disassembly

1. Remove bolts and nuts that attach operating nut and stuffing box.
2. Remove operating nut and stuffing box.
3. Back stem out of bonnet by turning in the closing direction.
4. Inspect O-rings and, if damaged, remove from stuffing box and stem. Replace with new O-rings and lubricate with food grade grease.
5. Inspect thrust washers and stuffing box gasket (O-ring) and replace if damaged.
6. Remove bolts and nuts that attach bonnet to valve body. Remove bonnet to inspect bonnet gasket, wedge nut, wedge and interior of valve body. Replace parts if damaged.

### Reassembly

Reassembly is the reverse of disassembly while paying attention to the following points.

1. Make sure wedge nut is seated fully into slot in wedge.
2. Make sure the bonnet gasket is positioned correctly on the valve body flange when bonnet is assembled onto valve body.
3. Lubricate stem threads with an AMERICAN Flow Control recommended food grade grease before installing into bonnet and threading into wedge nut. Turn stem in opening direction.
4. Position stuffing box gasket in top of bonnet and slide stuffing box onto stem being careful not to cut the stem seal O-rings.
5. Reinstall all bolts and nuts and tighten alternately to 70-90 ft-lb of torque.



# SERIES 2500 - STANDARD NRS REPAIRS, 4"–8"

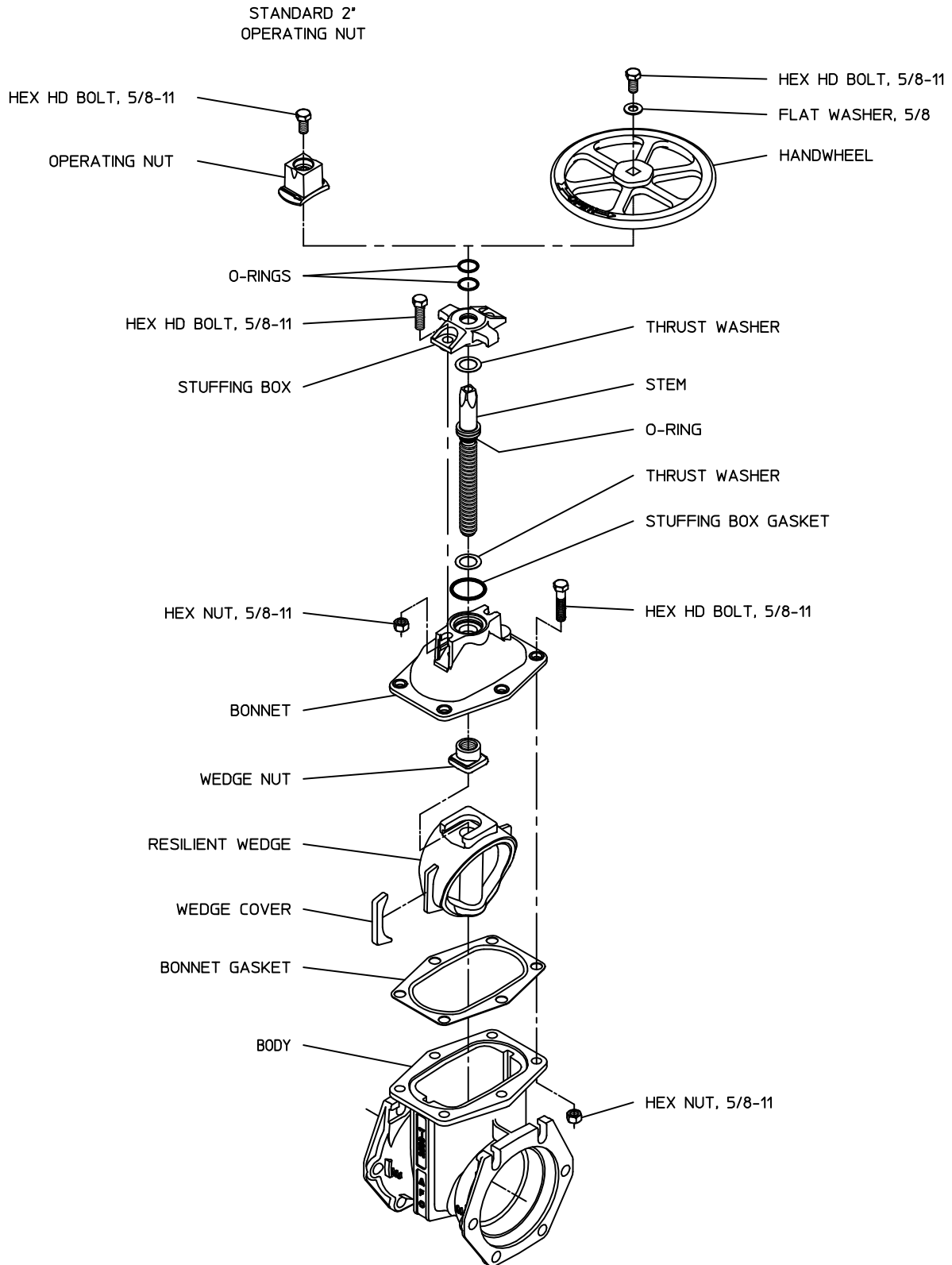

91-21789



**WARNING: Special care should be taken in the installation, inspection and repair of pressure containing devices such as valves and hydrants. FAILURE TO FOLLOW PROPER PRACTICE AND GUIDELINES CAN RESULT IN SERIOUS INJURY OR DEATH. Do not make repairs while valve is under pressure.**

### Disassembly

1. Remove bolts and nuts that attach operating nut and stuffing box.
2. Remove operating nut and stuffing box.
3. Back stem out of bonnet by turning in the closing direction.
4. Inspect O-rings and, if damaged, remove from stuffing box and stem. Replace with new O-rings and lubricate with food grade grease.
5. Inspect thrust washers and stuffing box gasket (O-ring) and replace if damaged.
6. Remove bolts and nuts that attach bonnet to valve body. Remove bonnet to inspect bonnet gasket, wedge nut, wedge and interior of valve body. Replace parts if damaged.

### Reassembly

Reassembly is the reverse of disassembly while paying attention to the following points.

1. Make sure wedge nut is seated fully into slot in wedge.
2. Make sure the bonnet gasket is positioned correctly on the valve body flange when bonnet is assembled onto valve body.
3. Lubricate stem threads with an AMERICAN Flow Control recommended food grade grease before installing into bonnet and threading into wedge nut. Turn stem in opening direction.
4. Position stuffing box gasket in top of bonnet and slide stuffing box onto stem being careful not to cut the stem seal O-rings.
5. Reinstall all bolts and nuts and tighten alternately to 70-90 ft-lb of torque.

# SERIES 2500 - STANDARD NRS REPAIRS, 10" & 12"

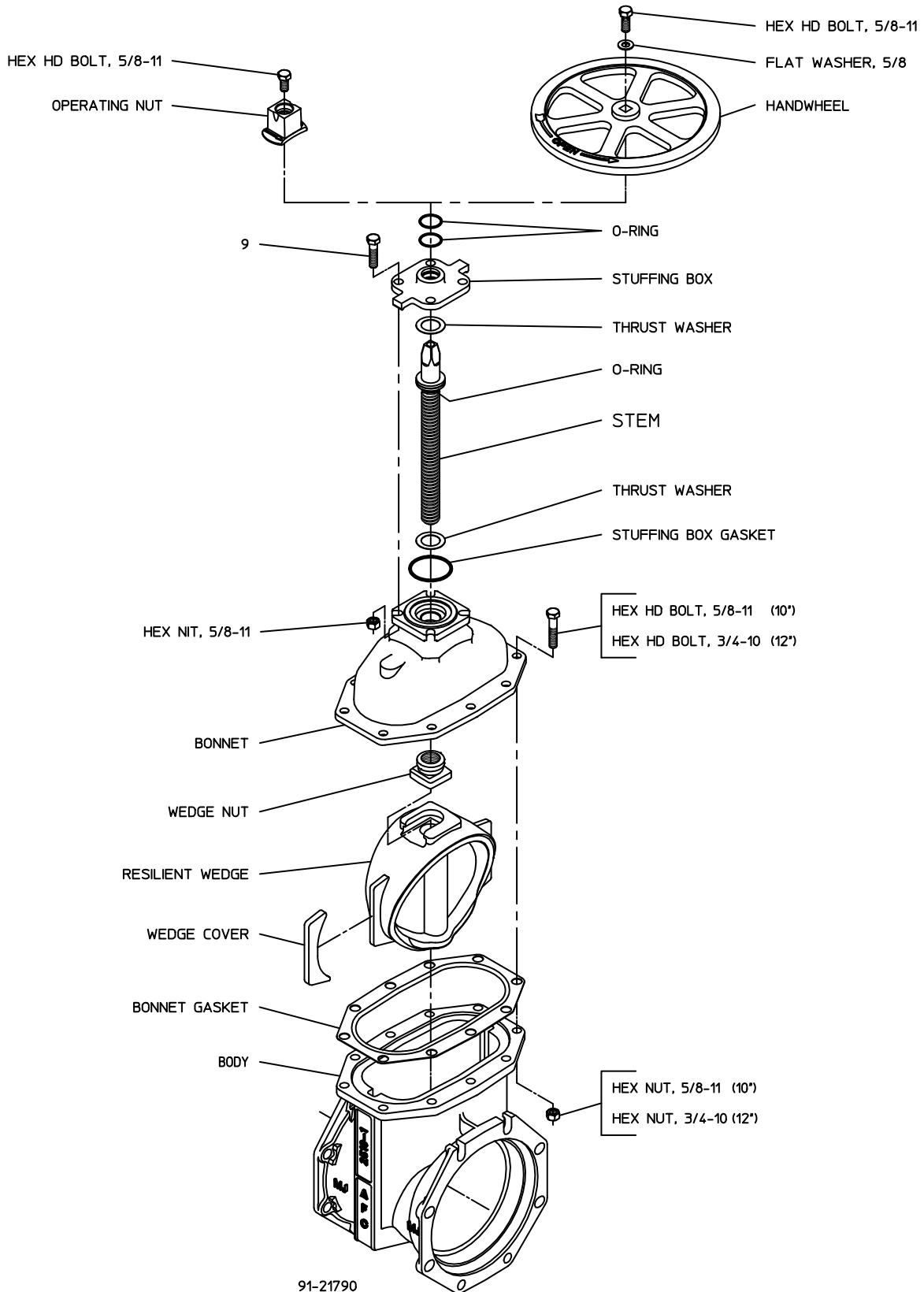

# SERIES 2500 - NRS WITH ENCLOSED MITER GEARING REPAIRS 3"—12"



## Disassembly

**WARNING: Special care should be taken in the installation, inspection and repair of pressure containing devices such as valves and hydrants. FAILURE TO FOLLOW PROPER PRACTICE AND GUIDELINES CAN RESULT IN SERIOUS INJURY OR DEATH. Do not make repairs while valve is under pressure.**

### Disassembling Miter gearing

1. Remove bolts and nuts that attach gear housing cover.
2. Remove bolt that attaches miter gear to gear shaft. Slide shaft out of opening in the gear housing.
3. Remove bolt that attaches miter gear to valve stem and pull miter gear from stem.
4. Remove gear housing from valve.
5. Inspect O-rings and if damaged, remove from gear housing and stem. Replace with new O-rings and lubricate with an AMERICAN Flow Control recommended food grade grease.

### Disassembling Valve

1. Back stem out of bonnet by turning in the closing direction.
2. Inspect O-rings and, if damaged, remove from gear housing and stem. Replace with new O-rings and lubricate with food grade grease.
3. Inspect thrust washers and stuffing box gasket (O-ring) and replace if damaged.
4. Remove bolts and nuts that attach bonnet to valve body. Remove bonnet to inspect bonnet gasket, wedge nut (4"—12"), wedge and interior of valve body. Replace parts if damaged.

## Reassembly

Reassembly is the reverse of disassembly while paying attention to the following points.

1. Make sure wedge nut (4"—12") is seated fully into slot in wedge.
2. Make sure the bonnet gasket is positioned correctly on the valve body flange when bonnet is assembled onto valve body.
3. Lubricate stem threads with an AMERICAN Flow Control recommended food grade grease before installing into bonnet and threading into wedge nut. Turn stem in opening direction.

4. Position stuffing box gasket in top of bonnet and slide gear housing onto stem being careful not to cut the stem seal O-rings.
5. Reinstall all bolts and nuts and tighten alternately to 70-90 ft-lb of torque.
6. Make sure the thrust washer is on the pilot of the miter gear when it is assembled onto the gear shaft. A dab of an AMERICAN Flow Control recommended food grade grease on the thrust washer will hold it on the gear.
7. The gear housing should be filled approximately half-full with food grade grease.

# SERIES 2500 - NRS WITH ENCLOSED MITER GEARING REPAIRS 3"–12"

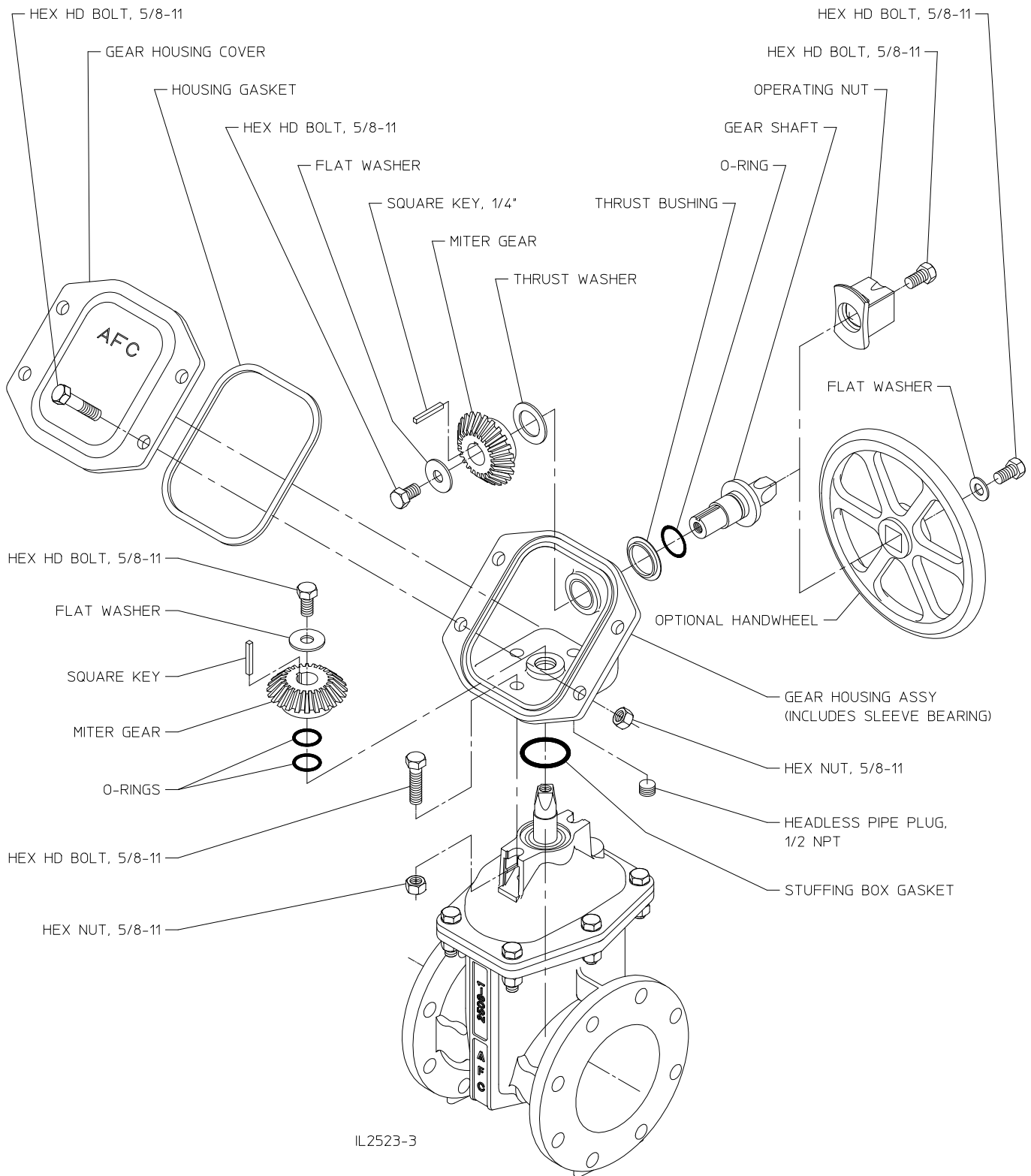



**WARNING: Special care should be taken in the installation, inspection and repair of pressure containing devices such as valves and hydrants. FAILURE TO FOLLOW PROPER PRACTICE AND GUIDELINES CAN RESULT IN SERIOUS INJURY OR DEATH. Do not make repairs while valve is under pressure.**

### Disassembly

1. Turn the handwheel to fully close the valve.
2. Loosen the packing gland nuts and remove the 2 bolts fastening the bonnet to the valve body.
3. Turn the handwheel to raise the bonnet away from the valve body and unthread the stem assembly from the stem.
4. Pull the wedge and stem assembly out the valve throat.
5. Remove the packing gland nuts, gland, gland follower and packing rings if necessary.
6. Loosen and remove the handwheel nut and yoke nut to remove handwheel. Do not lose the square key.
7. Drive out the pin in the wedge and unscrew the stem from the wedge.

### Reassembly

Reassembly is the reverse of disassembly with the following notes:

1. Carefully inspect and replace any damaged components. Lubricate all O-rings with an AMERICAN Flow Control recommended food grade grease.
2. Make sure the bonnet gasket is properly positioned on the valve body flange when the bonnet is assembled onto the valve body. Make sure the wedge nut is fully seated into the slot in the wedge.
3. Place the bonnet part-way onto the stem and insert the gland and gland-follower onto the stem. Raise the bonnet again and thread the yoke nut partially onto the stem.
4. Place the bonnet onto the lower yoke nut and turn the yoke nut and bonnet onto the stem until the bonnet contacts the throat gasket.
5. Using 2 hex head bolts, fasten the bonnet to the valve body.
6. Place the handwheel washer over the stem and onto the top of the yoke.
7. Slip the handwheel over the stem and onto the yoke nut. Insert the square key and replace the handwheel nut, tightening securely.
8. Raise the gland and gland-follower and replace the packing rings so that the joints in the rings are not aligned. Use the same number of packing rings as were removed.
9. Replace the gland-follower nuts and tighten only enough to prevent leakage of water past the stem.

# SERIES 2500 - OS & Y REPAIRS, 2" SIZE

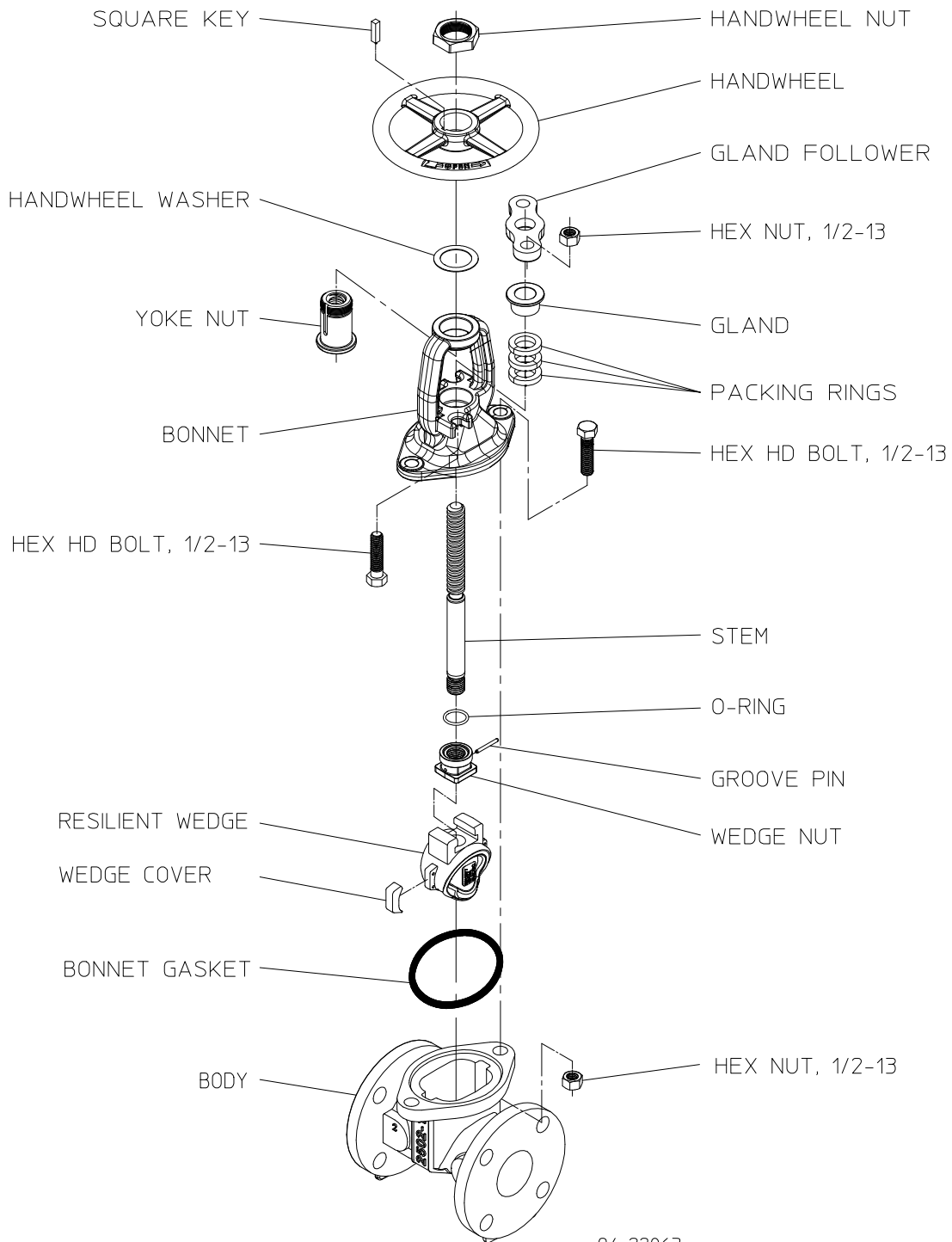



**WARNING: Special care should be taken in the installation, inspection and repair of pressure containing devices such as valves and hydrants. FAILURE TO FOLLOW PROPER PRACTICE AND GUIDELINES CAN RESULT IN SERIOUS INJURY OR DEATH. Do not make repairs while valve is under pressure.**

### Disassembly

1. Turn the handwheel to fully close the valve.
2. Mark the 2 stem nuts in line with each other - one mark on the top of the upper stem nut and one mark on the same side of the lower stem nut flange.
3. Remove the 2 hex-head bolts from the bonnet.
4. Loosen the gland-follower nuts.
5. Turn the handwheel in the closing direction to unscrew the pair of stem nuts from the stem. The handwheel, bonnet and handwheel washer will also be removed as they are trapped between the stem nuts. When the upper stem nut is fully unthreaded from the stem, the handwheel can be removed. When the lower stem nut is unthreaded from the stem, the bonnet, gland and gland-follower can be removed.
6. Grasping the stem, withdraw the stem and wedge assembly from the valve.
7. Drive the groove pin out of the wedge and unscrew the stem from the wedge.

### Reassembly

Reassembly is the reverse of disassembly with the following notes:

1. Carefully inspect and replace any damaged components. Lubricate all O-rings with an AMERICAN Flow Control recommended food grade grease.
2. Make sure the bonnet gasket is properly positioned on the valve body flange when the bonnet is assembled onto the valve body.
3. Place the bonnet part-way onto the stem tipping the top of the bonnet's yoke to the side. Raise the yoke off the top of the stem and place the gland and gland follower onto the stem. Raise the yoke again and thread the lower stem nut partially onto the stem. Note the position of the alignment mark and place the yoke onto the lower stem nut.
4. Place the handwheel washer on the top of the yoke.
5. Note the location of the alignment mark on the upper stem nut and place the nut in the handwheel. Place the handwheel and upper stem nut onto the yoke, engaging the teeth of the stem nuts so that the marks are aligned.
6. Turn the handwheel and yoke as a unit onto the stem until the yoke is nearly touching the bonnet.
7. Using 2 hex head bolts, fasten the bonnet to the valve body.
8. Raise the gland and gland-follower and replace the packing rings so that joints in the rings are not aligned. Use the same total number of packing rings as were removed.
9. Replace the gland-follower nuts and tighten only enough to prevent leakage of water past the stem.



SERIES 2500 - OS & Y REPAIRS, 2-1/2" & 3" SIZES

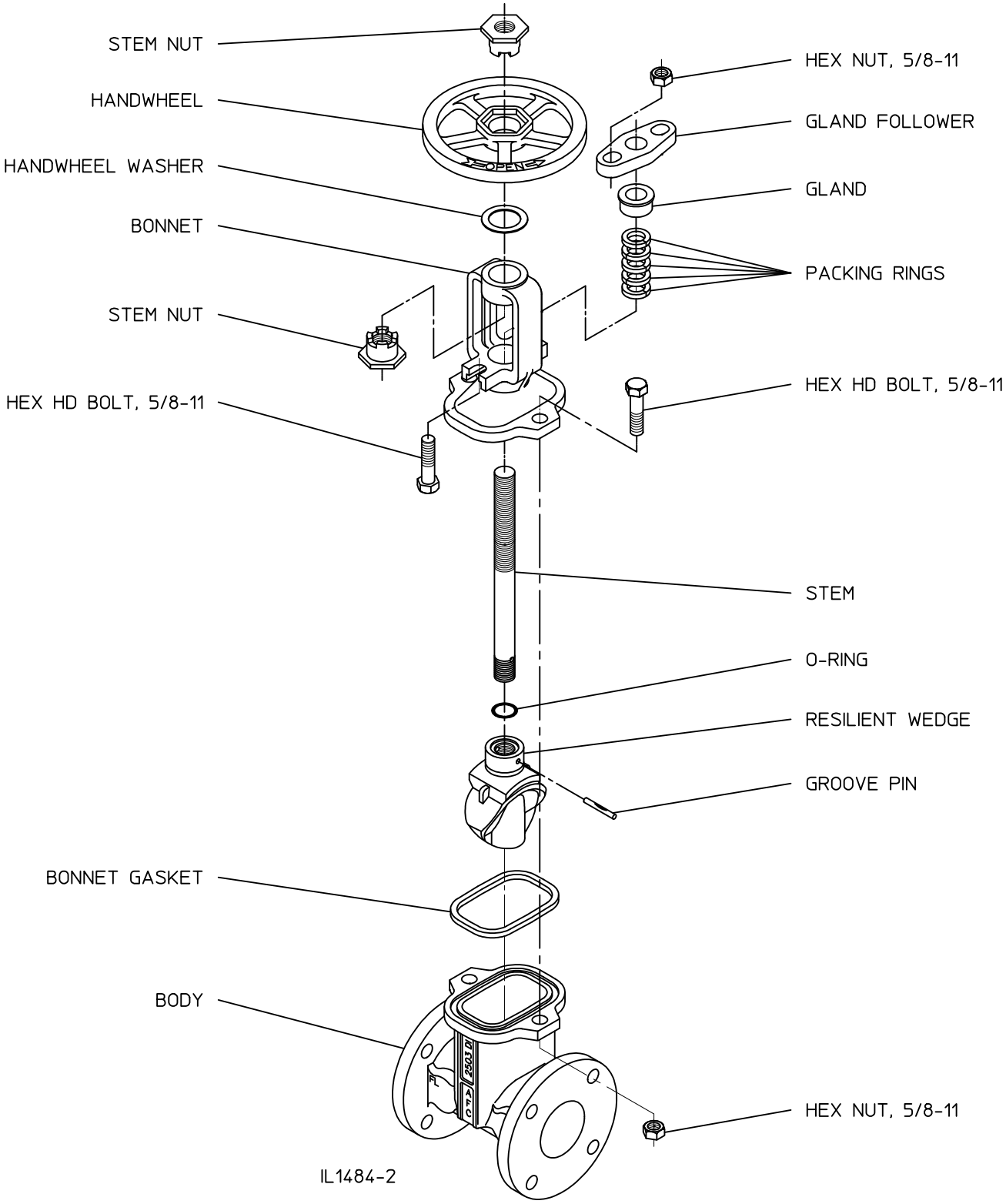

IL1484-2

## SERIES 2500 - OS & Y REPAIRS, 4"–8" SIZES



**WARNING: Special care should be taken in the installation, inspection and repair of pressure containing devices such as valves and hydrants. FAILURE TO FOLLOW PROPER PRACTICE AND GUIDELINES CAN RESULT IN SERIOUS INJURY OR DEATH. Do not make repairs while valve is under pressure.**

### Disassembly

1. Turn the handwheel to fully close the valve.
2. Mark the 2 stem nuts in line with each other, one mark on the top of the upper stem nut and one mark on the same side of the lower stem nut flange.
3. Remove the 2 hex-head bolts from the yoke.
4. Loosen the gland-follower nuts.
5. Turn the handwheel in the closing direction to unscrew the pair of stem-nuts from the stem. The handwheel, yoke and handwheel washer will also be removed as they are trapped between the stem-nuts. When the upper stem nut is fully unthreaded from the stem, the handwheel can be removed. When the lower stem nut is unthreaded from the stem, the yoke, gland and gland follower can be removed.
6. Remove the bonnet bolts and grasping the stem, withdraw the bonnet and wedge assembly from the valve.
7. Withdraw the stem and wedge assembly from the bonnet and remove the wedge from the stem by sliding the wedge nut out the side of the wedge slot.
8. Drive the groove pin out of the wedge nut and unscrew the stem from the wedge nut.

### Reassembly

Reassembly is the reverse of disassembly with the following notes:

1. Carefully inspect and replace any damaged components. Lubricate all O-rings with an AMERICAN Flow Control recommended food grade grease.
2. Make sure the wedge nut is fully seated into the slot in the wedge.
3. Make sure the bonnet gasket is properly positioned on the valve body flange when the bonnet is assembled onto the valve body.
4. After installing the wedge assembly and bonnet, place one packing ring in the bonnet then position the stuffing box gasket in the bonnet recess.
5. Place the yoke part-way onto the stem tipping the top of the yoke to the side. Raise the yoke off of the top of the stem and place the gland and gland-follower onto the stem. Raise the yoke again and thread the lower stem nut partially onto the stem. Note the position of the alignment mark and place the yoke onto the lower stem nut.
6. Note the position of the alignment mark and place the yoke onto the lower stem nut.
6. Place the handwheel washer on the top of the yoke.
7. Note the location of the alignment mark on the upper stem nut and place the nut in the handwheel. Place the handwheel and upper stem nut onto the yoke, engaging the teeth of the stem nuts so that the marks are aligned.
8. Turn the handwheel and yoke as a unit onto the stem until the yoke is nearly touching the bonnet.
9. Using 2 hex head bolts, fasten the yoke to the bonnet.
10. Raise the gland and gland-follower and replace the packing rings so that joints in the rings are not aligned. Use the same total number of packing rings as were removed.
11. Replace the gland-follower nuts and tighten only enough to prevent leakage of water past the stem.

# SERIES 2500 - OS & Y REPAIRS, 4" - 8" SIZES

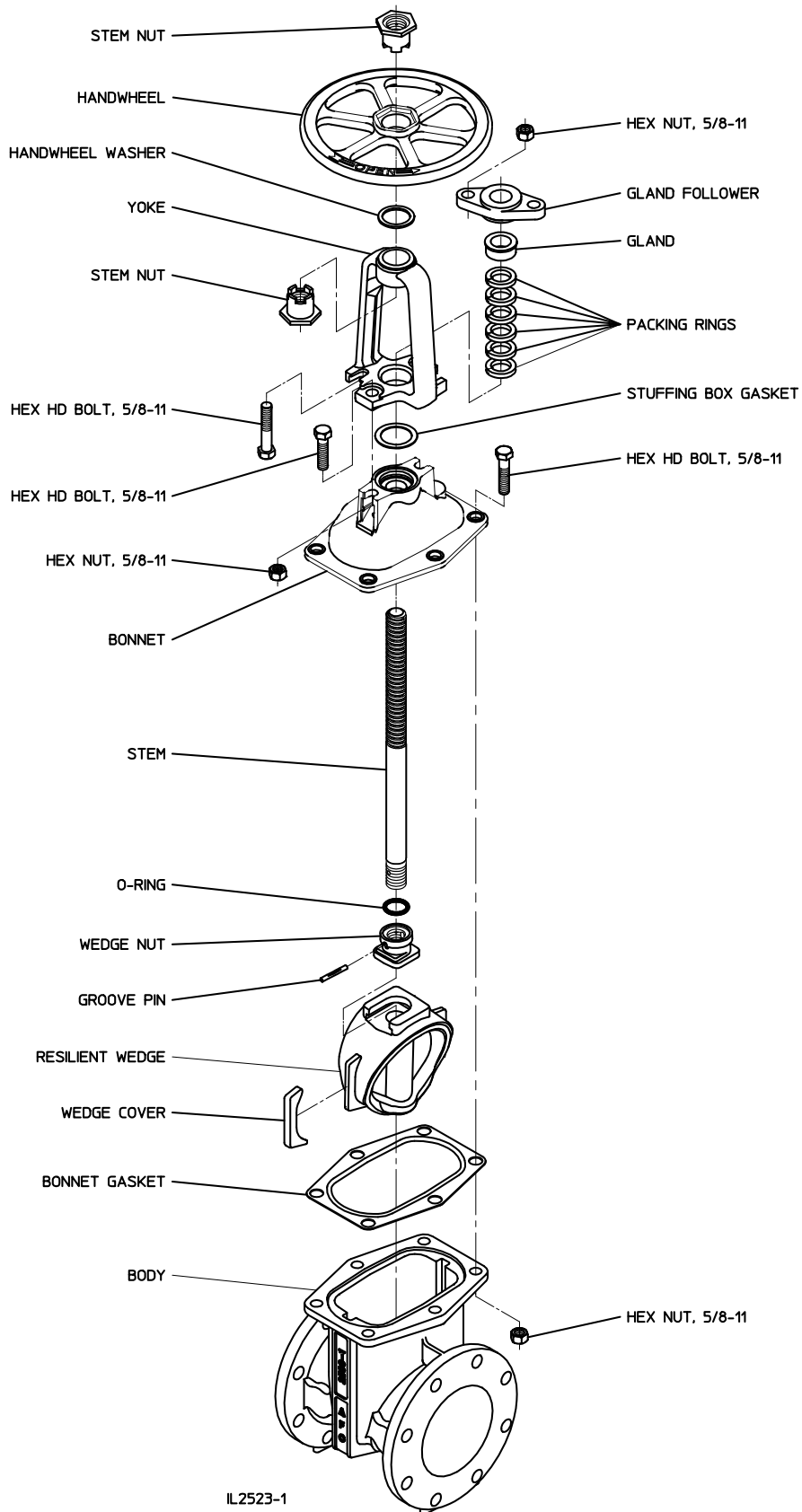

IL2523-1



**WARNING: Special care should be taken in the installation, inspection and repair of pressure containing devices such as valves and hydrants. FAILURE TO FOLLOW PROPER PRACTICE AND GUIDELINES CAN RESULT IN SERIOUS INJURY OR DEATH. Do not make repairs while valve is under pressure.**

### Disassembly

1. Turn the handwheel to fully close the valve.
2. Loosen the packing gland nuts and remove the 4 bolts fastening the yoke to the bonnet.
3. Turn the handwheel to raise the yoke away from the bonnet and unthread the assembly from the stem. Do not lose the square key.
4. Remove the bolts from the bonnet and lift the bonnet over and off of the stem.
5. Disengage the stem and wedge nut from the wedge by sliding the nut out of the slot in the wedge.
6. Drive out the pin in the wedge nut and unscrew the stem from the wedge nut.
7. Pull the wedge out of the valve throat.

### Reassembly

Reassembly is the reverse of disassembly with the following notes:

1. Carefully inspect and replace any damaged components. Lubricate all O-rings with an AMERICAN Flow Control recommended food grade grease.
2. Make sure the wedge nut is fully seated into the slot in the wedge.
3. Make sure the bonnet gasket is properly positioned on the valve body flange when the bonnet is assembled onto the valve body.
4. After installing the stem, wedge assembly and bonnet, position the stuffing box gasket in the bonnet recess.
5. Place the yoke part-way onto the stem tipping the top of the yoke to the side. Raise the yoke off the top of the stem and place the gland and gland follower onto the stem. Raise the yoke again and thread the yoke nut partially onto the stem. Place the yoke onto the yoke nut.
6. Turn the yoke nut and yoke onto the stem until the yoke contacts the bonnet.
7. Using 4 hex head bolts, fasten the yoke to the bonnet.
8. Place the handwheel washer over the stem and onto the top of the yoke.
9. Slip the handwheel over the stem and onto the yoke nut. Insert the square key and replace the handwheel nut, tightening securely.
10. Raise the gland and gland-follower and replace the packing rings so that joints in the rings are not aligned. Use the same number of packing rings as were removed.
11. Replace the gland-follower nuts and tighten only enough to prevent leakage of water past the stem.

# SERIES 2500 - OS & Y REPAIRS, 10"-24" SIZES

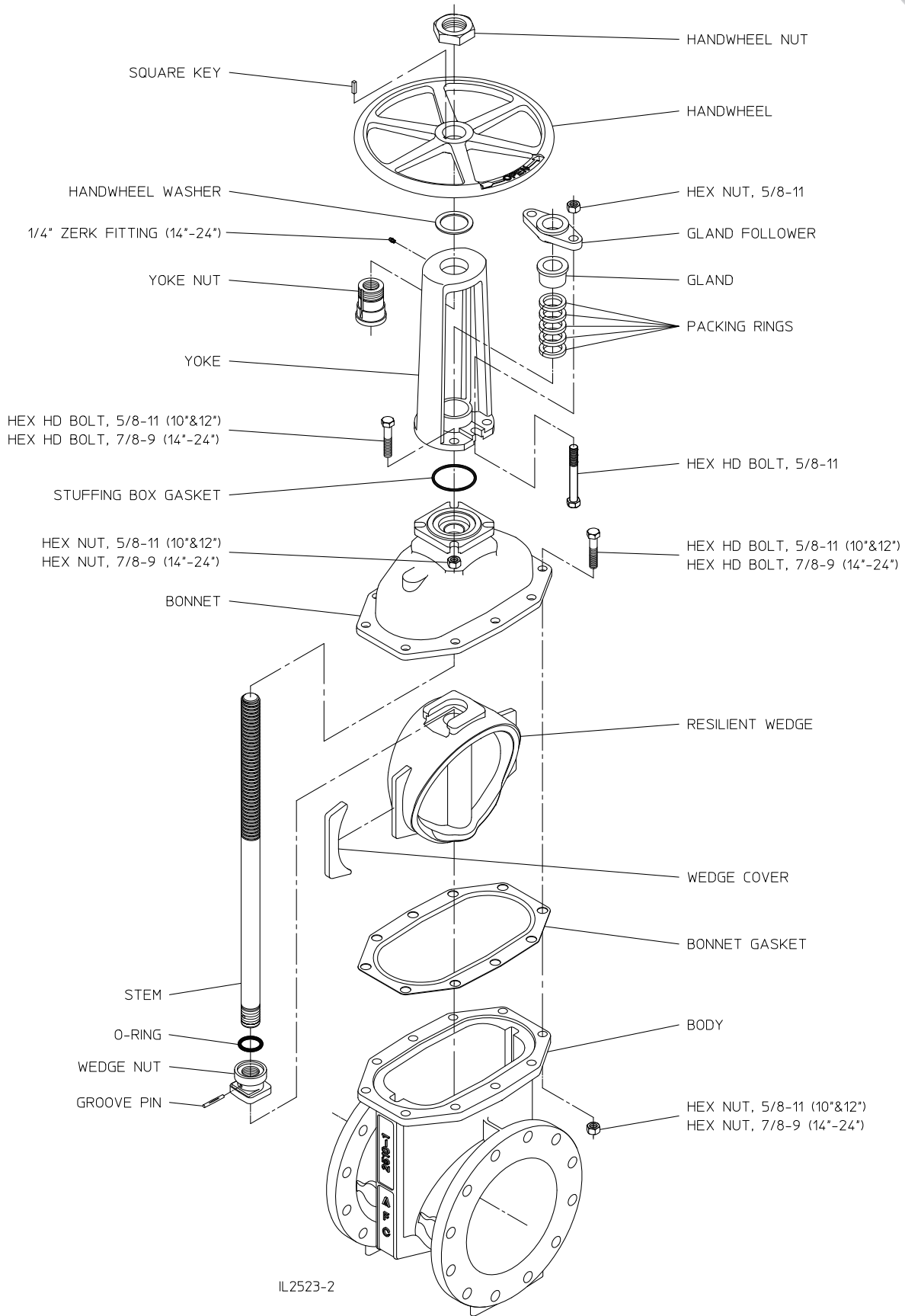

IL2523-2

## 2500 SPECIFICATIONS



Valves 2 in.—66in. shall be resilient wedge type rated for 250 psig cold water working pressure. All ferrous components shall be ductile iron. All NRS valves, in applicable configurations, 2-1/2in.—24in. in diameter shall be Listed by Underwriters Laboratories, Inc. All OS&Y valves in applicable configurations, 3in.—24in. in diameter shall be Listed by Underwriters Laboratories, Inc. Valves 3 in.—54 in. shall be in full compliance with ANSI/AWWA C515. The words "DI" or "Ductile Iron" shall be cast on the valve. The wedge shall be ductile iron encapsulated with EPDM rubber and provided with male type guides and polymer guide covers. Bolting shall be Type 304 stainless steel and shall be provided with hexagonal heads with dimensions conforming to ANSI B18.2.1. Metric size, socket head cap screws therefore are not allowed.

- Operating nut shall be constructed of ductile iron and shall have four flats at stem connection to assure even input torque to the stem.
- All gaskets shall be pressure energized O-rings.
- Stem shall be sealed by three O-rings. The top two O-rings shall be replaceable with valve fully open and while subject to full rated working pressure. O-rings set in a cartridge shall not be allowed.
- Valve shall have thrust washers located with (1) above and (1) below the thrust collar to assure trouble-free operation of the valve.
- All internal and external surfaces of the valve body and bonnet shall have a fusion-bonded epoxy coating, complying with ANSI/AWWA C550, applied electrostatically prior to assembly.
- Valves shall be certified to NSF/ANSI Standard 61 and NSF/ANSI 372.
- Valves shall be AMERICAN Flow Control's **Series 2500 or 2500-1 Resilient Wedge Gate Valve.**