

Cambridge Brass  
P.O. Box 249  
140 Orion Place  
Cambridge, Ontario  
Canada N1R 5V1  
Tel: (519) 621-5520  
Fax: (519) 621-8674  
http://www.cambridgebrass.com

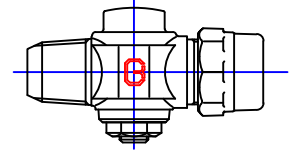

MODEL NO. 302NL

AWWA (CC) x CB COMPRESSION

CORPORATION MAIN STOP  
PLUG STYLE

AWWA/CC TAPER THREAD INLET x CB COMPRESSION  
FOR COPPER OR PLASTIC TUBING (CTS) OUTLET

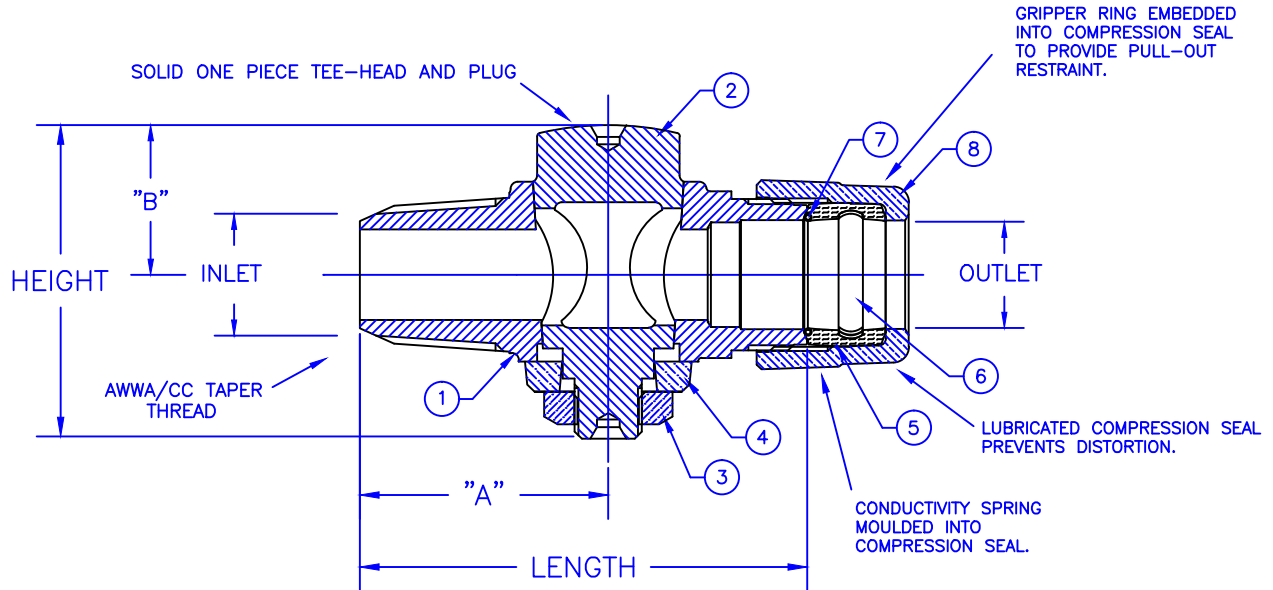

**PARTS AND MATERIAL:**

1. VALVE BODY: CAST BRASS, ALLOY C89833
2. TAPERED PLUG: CAST BRASS, ALLOY C89833
3. STOP NUT: CAST BRASS, ALLOY C83600
4. WASHER: CAST BRASS, ALLOY C83600
5. COMPRESSION SEAL: NITRILE RUBBER
6. GRIPPER: STAINLESS STEEL, TYPE 302
7. CONDUCTOR SPRING: BRASS
8. TAILNUT: CAST BRASS, ALLOY C83600

**FEATURES:**

- ALL COMPONENTS CONFORM TO AWWA C800-05 (ASTM B-584, UNS NO C89833 FOR BRASS PARTS IN CONTACT WITH POTABLE WATER, AND ASTM B-62 AND B-584, UNS NO C83600 FOR ALL OTHER BRASS PARTS).
- CONFORMS TO ANSI/NSF 61-8
- CONFORMS TO ANSI/NSF 372 (COMPLIANT WITH US Safe Drinking Water Act. PL 111-380)
- 100 PSI WORKING PRESSURE.
- BODY PROVIDES LARGE, RUGGED FLATS FOR PROPER INSTALLATION.
- FULL 360 DEGREE ROTATION.

Cambridge Brass considers the information in this submittal form to be correct at the time of publication. Item and option availability, including specifications, are subject to change without notice.

VALVE SIZE	CATALOG NO.	INLET AWWA (CC)	OUTLET CB COMP.	HEIGHT	LENGTH	"A"	"B"	APPROX. WT. LBS.
3/4"	302NL-A3H3	3/4"	3/4"	2.54"	3.69"	2.06"	1.21"	1.7
3/4"	302NL-A3H4	3/4"	1"	2.54"	3.78"	2.06"	1.21"	2.3
1"	302NL-A4H4	1"	1"	2.75"	4.22"	2.41"	1.30"	2.9

Submitted by: