

PE Electrofusion Systems for Gas and Water Catalog



ELECTROFUSION SYSTEMS

PE ELECTROFUSION SYSTEMS

For Gas and Water Applications



Engineered Smarter™



FRIATEC® PE Electrofusion Systems for Gas & Water

The IPEX FRIATEC brand of electrofusion products are engineered smarter than traditional fusion systems. Manufactured in the USA, FRIATEC couplings feature a unique, exposed coil design that provides a seal stronger than any other electrofusion system on the market. This is achieved for two reasons:

- The heat, created by the electrical current passing through the exposed coil of the FRIATEC coupling, is transferred directly to the PE pipe, and
- The coil protrudes from the interior surface of the coupling. When the pipe is heated, the coil sinks into it creating a much stronger bond.

Unlike competing embedded coil technology fittings which require heating the entire coupling, FRIATEC's unique "exposed coil" melts the fitting and pipe surfaces directly, sinking into the pipe to form a leak-proof bond. FRIATEC electrofusion fittings are designed with extra wide fusion zones that provide greater contact area, further increasing the integrity of the bond between coupling and pipe.

As a result of this process, every joint will be fused precisely to specification, automatically, every time, minimizing the risk of human error. This unique fusion technology has earned FRIATEC couplings the highest pressure rating in the industry. What's more, because every joint is as strong as the pipe itself, the FRIATEC electrofusion system is ideal for directional drilling and other trenchless applications.

With the industry's most advanced barcode monitoring, recording and tracking technology, FRIATEC makes managing your infrastructure easier than ever before.

Imagine, no more hidden costs or surprises on future dig ups. Instead, you will know when, where and how every coupling in your system was installed, and by whom.

All these benefits add up to deliver substantial time and cost savings on every project.



Table of Contents

Genesis F3 Electrofusion Processor	3
Couplings	6
Reducer.	10
Tapping Tees	11
Scraper Tools	17
Re-Round Clamps.	18
Saddles	20
Repair Patches and Clamps	23

GENESIS F3™
ELECTROFUSION
PROCESSOR

COUPLINGS
& REDUCER

TAPPING TEES

SCRAPER TOOLS

RE-ROUND CLAMPS

SADDLES

REPAIR PATCHES
& CLAMPS

GENESIS F3

Electrofusion Processor

- 120 Volt
- Processor permanently mounted in a hard shell Pelican™ case
- USB download port
- Standard machine supplied with a barcode pen scanner.
- Options include SmartScan™ and SmartScan™ with GPS
- Can be operated in Manual, Barcode ID or Resistor ID modes



Description

Product Code

Processor with barcode pen scanner	328244
Processor with SmartScan	328243
Processor with SmartScan with GPS	328242

Stores information on up to 1000 fusions

Windows® 7 Compatible

Calibration Window 3 years

Operator ID readable

Barcode readable without leads attached

AutoCal™ system allows processor to be recalibrated at customer's facility

3 handles so the processor can be carried easily by 2 people

Cable storage in lid

Lid opens 180 degrees

Weight 48 lbs meets Corporate Health and Safety limits of under 50 pounds



GENESIS F3 CONT'D

GENESIS F3 Specifications

Technical Data	
Parameter	Value
Supply Voltage	97 VAC to 150 VAC
Supply Frequency	47 Hz to 70 Hz
Supply Waveform	Sine Wave or Square Wave
Maximum Supply Current	30 Amps at 60 Amps Output (120 VAC)
Output Voltage	8 VAC to 48 VAC +/- 1.5%
Output Current	4 AAC to 60 AAC +/- 1.5% (80 AAC @ 42 VAC output)
Operating Temperature Range	0°F to 140°F
Operating Modes	Barcode, Manual, Manual Barcode, Resistor ID
Barcode Readability without Leads Attached	YES
Output Cable Length	12 feet
Input Cable Length	12 feet
Fusion Information Storage	1000 Fusions
Type A USB Port	USB A type connector for attaching a USB flash drive to download fusion data.
Type B USB Port	USB B type connector for attaching the AutoCal® field calibration system.
Languages	English/Spanish
Fitting Adapters	90 degree non-rotating
Weight	48 pounds
Environmental Protection	IP54 Splash-Proof
Calibration Interval	3 Years
Warranty	1 Year
Scanning	interchangeable Smart Scan/Smart Scan with GPS
GPS	Optional
IEC Protection Class	Class 1 Grounded
Calibration/Service	Field calibration capable
Weight	48 pounds



This device is fully compatible with the AutoCal® field calibration system.

Accessories for Genesis F3 Electrofusion Processor

Replacement Parts

Item	Part Number
Pen Scanner, Threaded Connector	328224
SMART Scanner, Genesis F3	328225
SMART Scanner with GPS, Genesis F3	328226
Display Shield	328230
Fitting Adapter, 4.0mm 90°	328231
Fitting Adapter, 4.7mm 90° w/White Pin	328232
Fitting Adapter, 4.7mm 90° w/Red ID Pin	328233
Smart Scanner Holster	328227
Barcode Pen Holster	328228
Accessory bag	328229
Genesis F3 Information Card	328234
Fuse, 2 Amp 250 Volt Slow-Blow, 5x20mm	328235

Accessories for Universal Electrofusion Processor

Description	Product Code
Marinco Adapter, Plug 30A to 15A	328000
Frialen® Silver Pipe Markers	328002
FRIAT00L Complete Software Kit includes: 328208, 328012 & 328013	328206
CD-ROM Software (only)	328208
Memory Box (only)	328012
Connection Cable: PC to Memory Box	328013
Connection Cable: PC to Friamat	328173
UPONOR / New Style Central Connectors (pair) 4.7mm	328015
Central Connectors (pair) 2.3mm	328016
Reader Wand Replacement	328063
Friafit® Adapter (pair)	328014
Aluminum Fusion Processor Carrying Case	328143
Fusion Lead End (pair)	328119



Couplings

1/2" CTS through 28" IPS

Our Couplings and Fittings deliver flexibility and reliability. No one offers a wider range of coupling sizes and every FRIATEC fitting is ASTM approved.

Short Designation MBI/UBI...OD

Field of Application Connections of PE Pipes 2406 and 3408/4710

Range of Application Gas up to 100 psi and water up to 160 psi

For higher pressure ranges, contact IPEX at 800-463-9572



1/2" CTS through 28" IPS cont'd

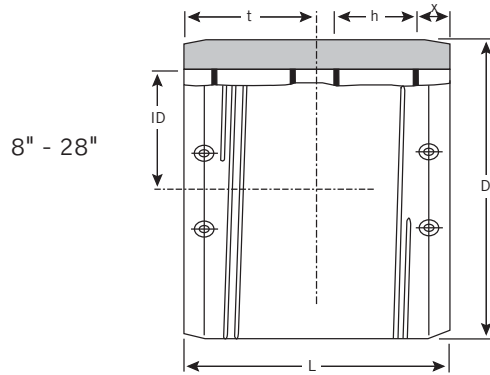
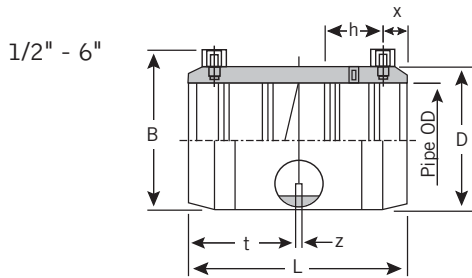

Nominal Pipe OD CTS	Product SDR	Product Code	ID min	ID max	D	B	L	t	z	h	x	Fusion Time/Sec @ 73°F	Cooling Time/Min */**/***
1/2"	11	128031	0.622	0.634	1.102	1.732	2.283	1.142	0.079	0.591	0.23	27	05/08/10
1"	11	128027	1.122	1.134	1.654	2.244	3.071	1.535	0.079	0.787	0.31	28	05/08/10

Nominal Pipe OD IPS	Product SDR	Product Code	ID min	ID max	D	B	L	t	z	h	x	Fusion Time/Sec @ 73°F	Cooling Time/Min */**/***
3/4"	11	128026	1.047	1.059	1.575	2.165	2.598	1.260	0.079	0.728	0.27	28	05/08/10
1"	11	128024	1.311	1.323	1.850	2.460	3.071	1.496	0.079	0.787	0.31	28	05/08/10
1-1/4"	11	128025	1.654	1.679	2.244	2.835	3.346	1.634	0.079	0.945	0.39	34	10/15/25
1-1/2"	11	128033	1.902	1.917	2.480	3.130	3.858	1.870	0.079	1.060	0.46	34	10/15/25
2"	11	128028	2.374	2.390	3.142	3.657	4.449	2.205	0.079	1.205	0.51	54	10/15/25
3"	11	128029	3.496	3.516	4.606	4.980	5.472	2.717	0.079	1.417	0.59	100	10/30/40
† 4"	11	128030	4.492	4.516	5.827	6.173	6.260	3.110	0.079	1.689	0.67	151	10/30/40
† 6"	11	128032	6.610	6.634	8.543	8.740	7.992	3.976	0.079	2.295	0.79	440	20/60/75
† 8" monofilar	11	128060	8.626	8.665	11.029	-	9.448	4.724	-	2.953	1.063	540	20/60/75
† 8" bifilar	11	128023	8.626	8.665	11.022	-	9.448	4.724	-	2.953	1.063	554 ea side	20/60/75
† 10"	11	128061	10.748	10.787	13.975	-	11.811	5.275	-	3.149	1.063	500 ea side	30/75/100
† 12"	11	128062	12.748	12.787	15.746	-	11.219	5.610	-	2.679	1.142	550 ea side	30/75/100
† 14"	11	128064	13.976	14.016	17.716	-	11.811	5.905	-	3.500	1.260	580 ea side	30/75/100
† 16"	11	128063	15.969	16.008	19.685	-	12.598	6.299	-	3.748	1.260	870/730 ea side	45/95/120
† 18"	11	128065	17.969	18.008	22.047	-	13.386	6.693	-	3.346	1.260	870/870 ea side	45/95/120
† 20"	11	128176	19.961	20.016	24.803	-	14.173	7.086	-	3.622	1.260	870/720 ea side	45/95/120
† 22"	17	128066	21.961	22.016	24.803	-	14.566	7.283	-	3.291	1.260	870/720 ea side	45/95/120
† 24"	13.5	128067	24.000	24.039	27.952	-	15.748	7.874	-	4.095	1.420	870/850 ea side	45/95/120
† 28"	17	128068	27.992	28.031	31.496	-	15.748	7.874	-	6.062	1.614	850/850 ea side	60/80/120

FRIATEC Safety Fittings can be fused to all PE pipes within melt index groups 003-050 and pipe SDR range 9.33 through 17.6.

- * Pipe can be moved after indicated cooling time (handling)
- ** Pipe can be pressurized after indicated cooling time (pressure <90 psi)
- *** Pipe can be pressurized after indicated cooling time (pressure >90 psi)
- † FM 200 psi, Short Designation: MBI...OD

Couplings cont'd

4" through 24" DIPS



Short Designation UBI... OD
 Field of Application Connections of PE Pipes 2406 and 3408/4710
 Range of Application Water up to 160 psi
 For higher pressure ranges, contact IPEX at 800-463-9572

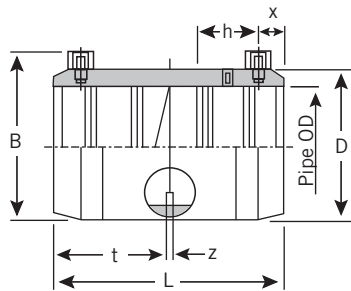

4"

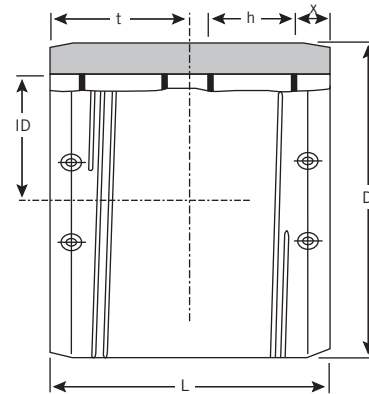

6" - 20"

Nominal Pipe OD	Product DIPS SDR	Product Code	ID min	ID max	D	L	t	h	x	Fusion Time/Sec @ 73°F	Cooling Time/Min **/**/**
4"	13.5	128183	4.799	4.819	5.669	6.354	3.177	1.765	0.827	100	15/20/30
6"	11	128134	6.889	6.929	8.825	8.268	4.134	2.535	0.827	486	20/60/75
8"	11	128131	9.039	9.078	11.022	9.448	4.724	2.953	0.827	540	30/75/100
10"	11	128136	11.082	11.122	13.976	11.023	5.511	3.291	0.827	550 ea side	30/75/100
12"	11	128132	13.182	13.224	15.746	11.023	5.511	2.582	0.827	550 ea side	30/75/100
14"	11	128158	15.272	15.311	18.000	11.417	5.708	3.500	0.827	730 ea side	40/95/120
16"	11	128135	17.385	17.444	22.047	11.417	5.708	3.392	0.827	870/720 ea side	40/95/120
18"	13.5	128138	19.472	19.531	22.047	11.417	5.708	3.392	0.827	870/720 ea side	40/95/120
20"	13.5	128133	21.582	21.641	24.803	11.417	5.708	2.460	0.827	870/720 ea side	40/95/120
24"	11	128207	25.732	25.791	32.000	16.535	8.268	4.764	0.827	870/1080 ea side	45/95/120

FRIATEC Safety Fittings can be fused to all PE pipes within melt index groups 003-050 and pipe SDR range 9.33 through 17.6.

- * Pipe can be moved after indicated cooling time (handling)
- ** Pipe can be pressurized after indicated cooling time (pressure <90 psi)
- *** Pipe can be pressurized after indicated cooling time (pressure >90 psi)

Please note 4", 18" or 20" DIP are rated SDR 13.5 and can be pressurized up to 150 psi (water)

Low Pressure Safety Electrofusion Couplings

(formally called Friafit)

The low pressure coupling can be fused to pipes of SDR stages 11 - 32 in accordance with ASTM F1055.

Pipes made of raw material types PE2406 and PE3408/4710, PE63, PE80 and P100 in melt index groups 005 - 050 can be fused.

It is possible to work with these couplings at ambient temperatures of between -4°F up to 122°F. It is always necessary to use a Friafit adapter for the fusion.

The thinwall safety coupling (AM) is made of PE3408 and can be pressurized up to a maximum of 80 psi if the pipe is of suitable design.

With exposed heating coils for optimal heat transfer, large insertion depth, extra wide fusion zones plus cold zones at the end and in the middle to prevent the flow of molten material for use without a holding device.

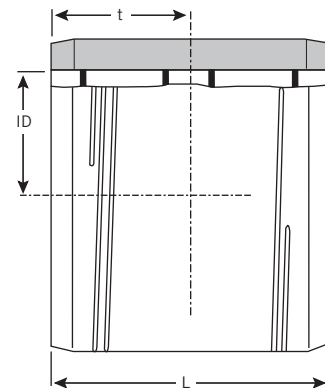

Size OD IPS	Product Code	Order No.	VE	PE	ID (in)	L (in)	t (in)	Weight lb/ea
8"	128139	190008-A	48	PE - HD	8.626	7.874	3.937	9
10"	128140	190010-A	32	PE - HD	10.748	8.268	4.134	11
12"	128141	190012-A	32	PE - HD	12.748	8.661	4.330	8
16"	128142	190016-A	16	PE - HD	16.008	8.661	4.330	16

Reducer

Reducer CTS x CTS & IPS x CTS



Field of Application Connections of PE Pipes 2406 and 3408/4710

Range of Application Gas up to 100 psi and water up to 160 psi
For higher pressure ranges, contact IPEX at 800-463-9572

- Increased coupler depth (no holding clamps required)
- Extra wide fusion zones
- Increased wall thickness providing maximum stability
- Front and middle cold zones
- Exposed heating coil with direct contact to pipe
- Contacts are safe to touch
- Visual fusion indicator
- Batch marking
- Individually wrapped

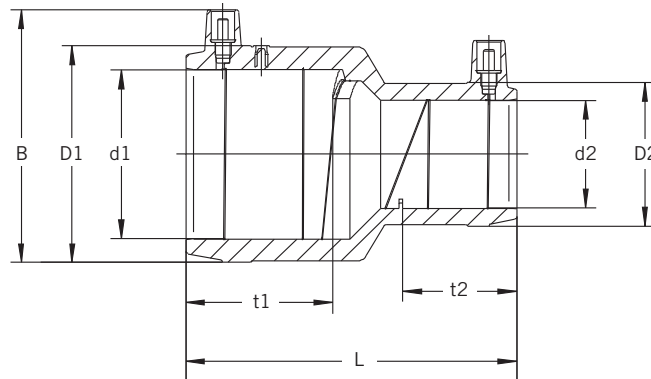

Nominal Pipe d1 (in)	Main Size d2 (in)	D1 (in)	D2 (in)	B (in)	L (in)	t1 (in)	t2 (in)	Weight lbs/ea
1 CTS	1/2 CTS	1.661	1.110	2.289	3.465	1.516	1.181	0.112
1 IPS	1/2 CTS	1.858	1.110	2.482	3.465	1.516	1.181	0.122
1-1/4 IPS	1 CTS	2.213	1.661	2.835	3.858	1.673	1.535	0.178
2 IPS	1 CTS	3.118	1.661	3.652	4.921	2.165	1.535	0.382

Tapping Tees

DAA High Pressure Tapping Tees - IPS

The industry-leading design of FRIATEC Tapping Tees makes for fast and safe installation of service and branch pipe.

Short Designation DAA d1./d2...

Field of Application Installation of service and branch pipes

Range of Application Gas up to 100 psi and water up to 160 psi

For higher pressure ranges, contact IPEX at 800-463-9572

- Hot tapping tee designed for leakproof installation under pressure up to 160 psi for water and 100 psi for gas
- Ease of assembly—no rounding clamps or special tools
- Cutter and sleeve made of brass
- Brass guide allows easy cutting of thick wall pipe
- Lower and upper "cutter stops" prevent overcutting as well as accidental removal of cutter
- Threaded plug with o-ring seal
- Corrosion-proof construction

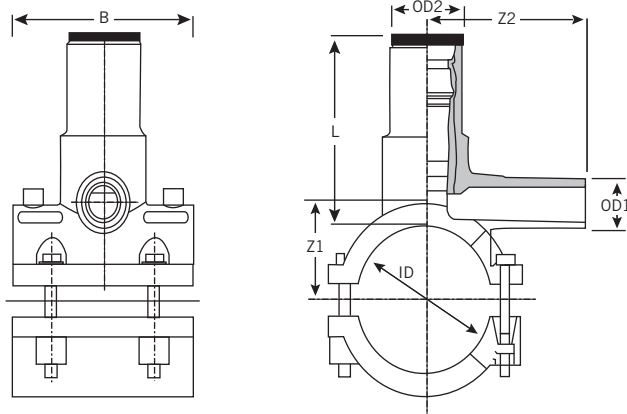

FRIATEC Safety Fittings can be fused to all PE pipes within melt index groups 003-050 and Pipe SDR Range 9.33 through 17.6. For Pipe SDR Range 21+, contact IPEX for **reduced** fusion times. Allow electrofusion joints to cool prior to handling, pressurizing or tapping.

Tapping Tees con't

DAA High Pressure Tapping Tees - IPS

Nominal Pipe OD IPS	Nominal Outlet	Product Code	ID	OD 1	OD 2	Cutter	L	Z1	Z2	B
1-1/4"	1/2" CTS	228020	1.575	0.626	1.259	0.630	2.913	1.102	9.624	2.756
1-1/4"	3/4" IPS	228021	1.575	1.051	1.259	0.630	2.913	1.102	9.624	2.756
1-1/4"	1" CTS	228022	1.575	1.126	1.259	0.630	2.913	1.102	9.624	2.756
1-1/4"	1" IPS	228023	1.575	1.315	1.259	0.630	2.913	1.102	9.624	2.756
2"	1/2" CTS	228042	2.378	0.626	1.575	0.846	3.878	1.780	3.937	4.094
2"	3/4" IPS	228029	2.378	1.051	1.575	0.846	3.878	1.780	3.701	4.094
2"	1" CTS	228033	2.378	1.126	1.575	0.846	3.860	1.780	3.701	4.094
2"	1" IPS	228032	2.378	1.315	1.575	0.846	3.860	1.780	3.701	4.094
2"	2" IPS	228274	2.378	2.378	1.575	1.180	5.000	2.170	5.952	6.060
3"	1/2" CTS	228043	3.504	0.626	1.969	1.180	4.764	2.343	4.410	4.803
3"	3/4" IPS	228030	3.504	1.051	1.969	1.180	4.764	2.343	3.937	4.803
3"	1" CTS	228031	3.504	1.126	1.969	1.180	4.764	2.343	4.255	4.803
3"	1" IPS	228044	3.504	1.315	1.969	1.180	4.764	2.343	4.255	4.803
3"	2" IPS	228028	3.504	2.378	1.969	1.180	4.780	2.350	6.890	5.905
4"	1/2" CTS	228045	4.512	0.626	1.969	1.180	4.764	2.905	4.016	4.785
4"	3/4" IPS	228034	4.512	1.051	1.969	1.180	4.764	2.846	4.409	4.764
4"	1" CTS	228035	4.512	1.126	1.969	1.180	4.764	2.846	4.527	4.785
4"	1" IPS	228046	4.512	1.315	1.969	1.180	4.764	2.913	4.527	4.785
4"	2" IPS	228025	4.512	2.378	1.969	1.180	4.780	2.913	7.086	4.905
6"	1/2" CTS	228047	6.638	0.626	1.969	1.180	6.575	4.500	4.586	7.677
6"	3/4" IPS	228036	6.638	1.051	1.969	1.180	6.575	4.528	4.331	7.677
6"	1" CTS	228038	6.638	1.126	1.969	1.180	6.575	4.528	4.331	7.677
6"	1" IPS	228049	6.638	1.315	1.969	1.180	6.575	4.528	4.331	7.677
6"	2" IPS	228027	6.638	2.378	1.969	1.180	6.575	4.803	6.811	7.677
8"	1/2" CTS	228048	8.605	0.626	1.969	1.180	6.575	5.483	4.586	7.677
8"	3/4" IPS	228037	8.605	1.051	1.969	1.180	6.575	5.315	4.331	7.677
8"	1" CTS	228041	8.605	1.126	1.969	1.180	6.575	5.315	4.331	7.677
8"	1" IPS	228040	8.605	1.315	1.969	1.180	6.575	5.315	4.331	7.677
8"	2" IPS	228039	8.605	2.378	1.969	1.180	6.575	5.827	6.811	7.677
10" - 16" *	2" IPS	228056	10.75 - 16.00	--	1.969	1.180	6.575	--	7.087	7.677

* Friatop pneumatic top-loading tool required

FRIATEC Safety Fittings can be fused to all PE pipes within melt index groups 003-050 and Pipe SDR Range 9.33 through 17.6. For Pipe SDR Range 21+, contact IPEX for **reduced** fusion times.

Allow electrofusion joints to cool prior to handling, pressurizing or tapping.

For 12" and 14" IPS applications, maximum SDR for full coupon cut is SDR 11.

For 16" IPS applications, maximum SDR for full coupon cut is SDR 13.5.

For 12" DIP applications, maximum SDR for full coupon cut is SDR 11.

For 14" and 16" DIP applications, maximum SDR for full coupon cut is SDR 17.

DAA High Pressure Tapping Tees - DIP

The DAA is easy to assemble and delivers a high quality design for the gas and water industry.

Short Designation DAA d1./d2...

Field of Application Installation of service and branch pipes

Range of Application Gas up to 100 psi and water up to 160 psi

For higher pressure ranges, contact IPEX at 800-463-9572



- Hot tapping tee designed for leakproof installation under pressure up to 160 psi for water and 100 psi for gas
- Ease of assembly—no rounding clamps or special tools
- Cutter and sleeve made of brass
- Brass guide allows easy cutting of thick wall pipe
- Lower and upper “cutter stops” prevent overcutting as well as accidental removal of cutter
- Threaded plug with o-ring seal
- Corrosion-proof construction



Nominal Pipe OD	Nominal DIP Outlet (in)	Product Code	ID	OD 1	OD 2	Cutter	L	Z1	Z2	B
4"	1/2" CTS	228251	4.512	0.626	1.969	1.201	4.764	2.905	4.016	4.785
4"	3/4" IPS	228252	4.512	1.051	1.969	1.201	4.764	2.846	4.409	4.764
4"	1" CTS	228250	4.512	1.126	1.969	1.201	4.764	2.846	4.527	4.785
4"	2" IPS	228253	4.512	2.378	1.969	1.201	4.780	2.913	7.086	4.905
6"	1/2" CTS	228254	6.638	0.626	1.969	1.201	6.575	4.500	4.586	7.677
6"	3/4" IPS	228255	6.638	1.051	1.969	1.201	6.575	4.528	4.331	7.677
6"	1" CTS	228256	6.638	1.126	1.969	1.201	6.575	4.528	4.331	7.677
6"	2" IPS	228257	6.638	2.378	1.969	1.201	6.575	4.803	6.811	7.677
8"	1/2" CTS	228258	8.605	0.626	1.969	1.201	6.575	5.483	4.586	7.677
8"	3/4" IPS	228259	8.605	1.051	1.969	1.201	6.575	5.315	4.331	7.677
8"	1" CTS	228260	8.605	1.126	1.969	1.201	6.575	5.315	4.331	7.677
8"	2" IPS	228261	8.605	2.378	1.969	1.201	6.575	5.827	6.811	7.677

FRIATEC Safety Fittings can be fused to all PE pipes within melt index groups 003-050 and Pipe SDR Range 9.33 through 17.6. For Pipe SDR Range 21+, contact IPEX for **reduced** fusion times.

Allow electrofusion joints to cool prior to handling, pressurizing or tapping.

Tapping Tees con't

DAA Tapping Tee Accessories



Description	Product Code
10mm Hex Wrench for 1-1/4" Main DAA Tees	228050
17 mm Hex Wrench for 2" Main DAA Tees	228051
19mm Hex Wrench for 2" x 2" and 3" - 16" Main DAA Tees	228052
Friatop Pneumatic Top Loading Tool for 10" - 16" DAA-TL and all TL fittings	228053
Pressure Test Cap Adapter (optional) for DAA style 1-1/4" Tees	228024
Pressure Test Cap Adapter (optional) for DAA style 2" - 16" Tees	228055

DAS II Top Loading Tapping Tees

Short Designation DAS II d1./d2...
 Field of Application Installation of service and branch pipes
 Range of Application Gas up to 100 psi and water up to 160 psi
 For higher pressure ranges, contact IPEX at 800-463-9572



- Top loading
- High volume
- Self-tapping tee
- Internal cutter blade that is the largest on the market

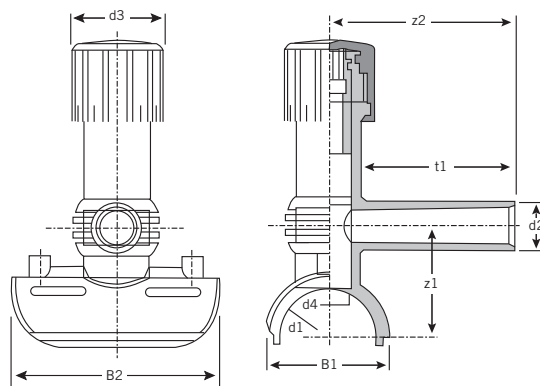

Nominal Pipe Main Outlet	Product Code	d3	L	z1	z2	t1	B1	B2	d4
2" IPS x 1/2" CTS	228110	2.165	5.748	2.559	3.449	2.717	2.795	4.724	1.016
2" IPS x 3/4" IPS	228111	2.165	5.748	2.559	3.843	3.110	2.795	4.724	1.016
2" IPS x 1" CTS	228112	2.165	5.748	2.559	4.236	3.504	2.795	4.724	1.016
2" IPS x 1-1/4" IPS	228123	2.402	5.000	2.157	4.677	3.740	2.795	4.724	1.214
2" IPS x 2" IPS	228124	2.402	5.000	2.319	6.496	5.559	2.795	4.724	1.214
4" IPS x 1/2" CTS	228113	2.165	5.827	3.524	3.449	2.717	4.528	5.906	1.016
4" IPS x 3/4" IPS	228114	2.165	5.827	3.524	3.843	3.110	4.528	5.906	1.016
4" IPS x 1" CTS	228115	2.165	5.827	3.524	4.236	3.504	4.528	5.906	1.016
4" IPS x 1-1/4" IPS	228126	3.268	8.386	4.114	5.512	4.114	4.528	5.906	1.798
4" IPS x 2" IPS	228127	3.268	8.386	4.449	5.512	4.114	5.039	5.906	1.798
6" IPS x 1/2" CTS	228116	2.165	5.827	4.449	3.449	2.717	5.039	5.906	1.016
6" IPS x 3/4" IPS	228117	2.165	5.827	4.449	3.843	3.110	5.039	5.906	1.016
6" IPS x 1" CTS	228118	2.165	5.827	4.449	4.236	3.110	5.039	5.906	1.016
6" IPS x 1-1/4" IPS	228128	3.268	8.386	4.449	5.512	4.114	5.039	5.906	1.798
6" IPS x 2" IPS	228129	3.268	8.386	4.449	6.299	4.902	5.039	5.906	1.798
8" IPS x 1/2" CTS	228120	2.165	6.457	4.921	3.449	2.717	5.827	5.906	1.016
8" IPS x 3/4" IPS	228121	2.165	6.457	4.921	3.843	3.110	5.827	5.906	1.016
8" IPS x 1" CTS	228122	2.165	6.457	4.921	4.236	3.504	5.827	5.906	1.016
8" IPS x 1-1/4" IPS	228130	3.268	8.976	4.921	5.512	4.114	5.827	5.906	1.798
8" IPS x 2" IPS	228131	3.268	8.976	4.921	6.299	4.902	5.827	5.906	1.798

FRIATEC Safety Fittings can be fused to all PE pipes within melt index groups 003-050 and Pipe SDR Range 9.33 through 17.6. For Pipe SDR Range 21+, contact IPEX for **reduced** fusion times.

Allow electrofusion joints to cool prior to handling, pressurizing or tapping.

Tapping Tees con't

DAS II Top Loading Tapping Tee Accessories



Description	Product Code
Top Loading Tool and Tapping Tools (complete set) Includes: 228065, 228066, 228072, 228073, 228074, 228075, 228077, 228078, 228079 and 228080	228067
Top Loading Tool (only) Includes: Top Bar and Ratchet	228075
25mm Top Loading Cap (adapter only)	228072
33mm Top Loading Cap (adapter only)	228073
50mm Top Loading Cap (adapter only)	228074
15mm DAS II Tap Tool (only)	228065
24mm DAS II Tap Tool (only)	228066
DAS Lock Pin	228077
DAS Short Strap	228078
DAS Long Strap	228079
DAS Standard Case	228080
25mm Aluminum Test Cap	228057
33mm Aluminum Test Cap	228058
50mm Aluminum Test Cap	228059

Scraper Tools

Scraper Tools with Accessories

FRIATEC scraper tools are designed to assist the installer in producing a quality electrofusion joint. With our Scraper Tools a quality electrofusion joint can be achieved every time.

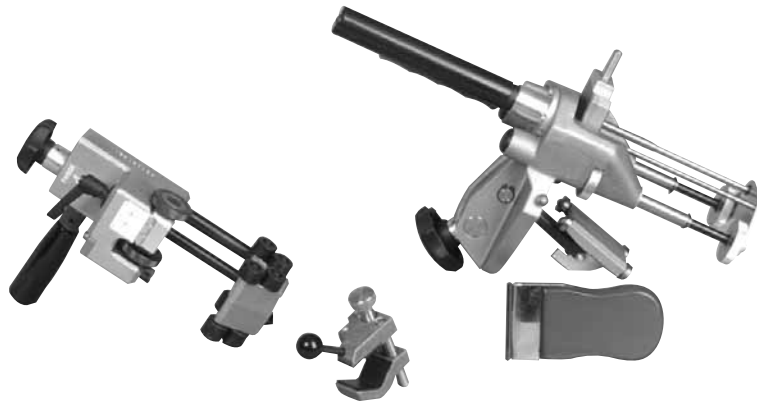
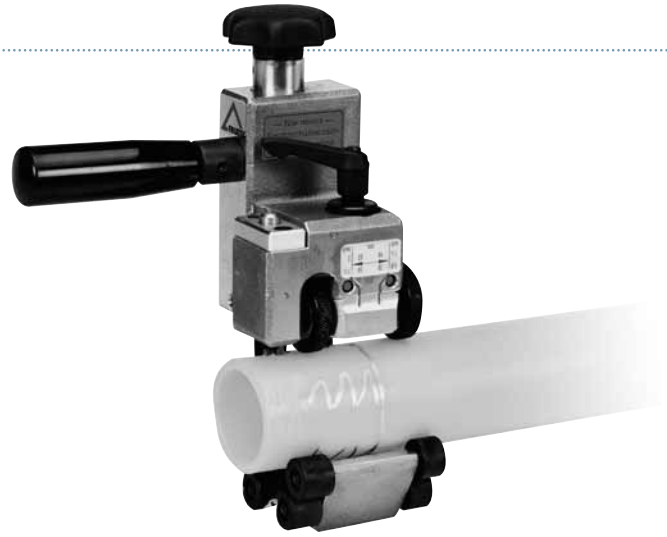

Scraper Tools	Product Code	Pipe Size Compatibility
FWZ Hand Scraper	328018	all
GBZ Pocket Scraper	128020	1/2" CTS - 1-1/4" CTS
FWSG 63 Scraper Tool w/ Case	128034	1/2" IPS - 2" IPS
FWSG 315 Scraper Tool w/ Case	128036	3" IPS - 8" IPS 4" DIP - 6" DIP
Scraper Tools w/ Case (complete set) Includes: FWSG 63 & FWSG 315	128039	1/2" IPS - 2" IPS 3" IPS - 10" IPS 4" DIP - 6" DIP
FWSG 710 Scraper Tool w/ Case	128190	6" IPS - 28" IPS 6" DIP - 20" DIP

Accessories	Product Code
Spare Blades for FWZ Hand Scraper (set of 5 blades)	328017
Spare Blade Kit for FWSG 63 3 blades, 2 screws, 1 driver	128041
Spare Blade Kit for FWSG 315 3 blades, 2 screws, 1 driver	128040
Spare Blade Kit for FWSG 630/710 3 blades, 2 screws, 1 driver	128042
Aluminum Carrying Case for FWSG 630-710 Scraper Tool	128198
Aluminum Carrying Case for FWSG 63-315 Scraper Tool	128035

Re-Round Clamps

Hydraulic Re-Round Clamps



If the end of a PE pipe is not perfectly round, the coupling will not fit over the end of the pipe. Our Re-Round Clamps solve this problem.

The clamping unit is comprised of:

- 1 – Hydraulic clamping unit
- 2 – Component inserts

Description - IPS	Product Code
14" IPS Master Re-Round Clamp	228152
16" IPS Re-Round Insert	228158
18" IPS Master Re-Round Clamp	228154
20" IPS Master Re-Round Clamp	228161
d 630mm Large Master Re-Round Clamp 22" - 24"	228156
22" IPS Re-Round Insert	228159
24" IPS Re-Round Insert	228160
28" IPS Master Re-Round Clamp	228217

Description - DIP	Product Code
8" DIP Re-Round Insert	228162
10" DIP Master Re-Round Insert	228151
12" DIP Master Re-Round Clamp	228153
12" DIP Re-Round Insert	228163
16" DIP Master Re-Round Clamp	228155
16" DIP Re-Round Insert	228164
18" DIP Master Re-Round Clamp (20" IPS master)	228161
20" DIP Re-Round Insert (requires 228156 d 630mm Master Re-Round Clamp)	228165

Alignment Clamps - IPS / DIP

Each alignment clamp listed in the table aligns only one size pipe. Select tool according to pipe size to be aligned.



Description - Single	Product Code
1-1/4" IPS	228244
2" IPS	228137
3" IPS	228248
4" IPS	228138
4" DIP	228263
6" IPS	228139
6" DIP	228264
8" IPS	228246

Description - Double	Product Code
1-1/4" IPS	228245
2" IPS	228140
3" IPS	228249
4" IPS	228141
6" IPS	228142
8" IPS	228247

Manual Re-Rounding Tools

Our industrial-quality re-rounding tools for the gas and water industries has a reputation of being the best-quality tools on the market.

Description	Product Code
6" IPS/DIP - 12" IPS/DIP Re-Round Tool	228271
12" IPS/DIP - 20" IPS/DIP Re-Round Tool	228278
20" IPS - 28" IPS & 20" - 24" DIP Re-Round Tool	228275



Saddles

VA Electrofusion Service Saddles



Short Designation VA, VA-TL d1./d2...
 Field of Application Installation of service and branch pipes
 Range of Application Gas up to 100 psi and water up to 160 psi
 For higher pressure ranges, contact IPEX at 800-463-9572

FRIATEC Molded Saddle Fittings may be clamped onto pipes up to SDR 9 and sealed using electrofusion. In addition to house connection fittings, FRIATEC Molded Saddle Fittings can also be used as branch saddles for polyethylene relining pipes (U-liners, C-liners, Roll-down)

Benefits include:

- universal compatibility with various diameters of polyethylene pipe from 3" up to 22"
- quick, easy and safe assembly

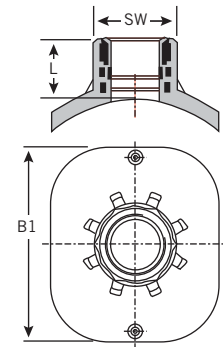
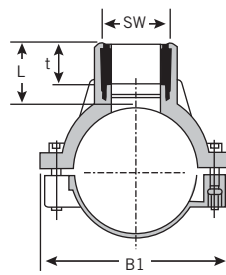
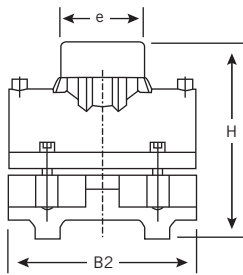

Nominal Pipe d1 (in)	Main Size d2	Nominal Outlet	Product Code	B1	B2	H	L	t	e
3"	IPS	2" SSPT	228262	6.102	5.906	7.835	3.740	1.063	3.189
4"	IPS	2" SSPT	228170	6.890	7.087	8.228	3.740	1.063	3.189
4"	DIP	2" SSPT	228298	6.890	7.087	8.228	3.740	1.063	3.189
6"	IPS	2" SSPT	228171	8.858	7.677	10.197	3.740	1.063	3.189
6"	DIP	2" SSPT	228302	8.858	7.677	10.197	3.740	1.063	3.189
8" - TL *	IPS	2" SSPT	228218	9.843	7.677	11.693	3.740	1.063	3.189
8" - TL *	DIP	2" SSPT	228173	10.039	7.677	12.283	3.740	1.063	3.189
10" - 22" TL *	IPS	2" SSPT	228174	7.874	--	--	3.543	--	--
10" - 20" TL *	DIP	2" SSPT							

* FRIATEC Pneumatic Top-loading tool required

FRIATEC Safety fittings can be fused to all PE pipes within melt index groups 003-050 and SDR range 9.33 through 17.6.
 Assemble nipple, bushing or corporation stop into saddle using red LOCTITE #262
 (SSPT) = Straight Standard Pipe Thread. The use of tapered fittings for the outlet is not permitted

SA Branch Saddles

Short Designation SA, SA-TL d1./d2...
 Field of Application Installation of service and branch pipes
 Range of Application Gas up to 100 psi and water up to 160 psi
 SA Branch Saddles are available with either a 2" or 3" outlet
 For higher pressure ranges, contact IPEX at 800-463-9572

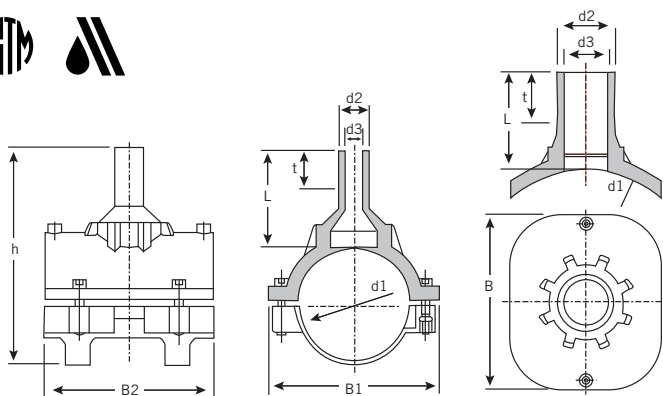

Nominal Pipe d1 (in)	Main Size d2	Nominal Outlet	Product Code	d3	L	h	t	B1	B2
3"	IPS	2 IPS	228184	1.969	4.055	8.150	2.756	6.102	5.906
4"	IPS	2 IPS	228185	1.929	4.291	9.173	2.205	6.890	7.087
4"	DIP	2 IPS	228296	1.929	4.291	9.173	2.205	6.890	7.087
4"	IPS	3 IPS	228186	2.756	4.528	8.976	3.543	6.496	7.480
4"	DIP	3 IPS	228297	2.756	4.528	8.976	3.543	6.496	7.480
6"	IPS	2 IPS	228144	1.850	4.291	11.142	2.205	8.858	7.677
6"	DIP	2 IPS	228305	1.850	4.291	11.142	2.205	8.858	7.677
6"	IPS	3 IPS	228180	2.717	5.079	11.496	3.937	8.543	9.646
6"	DIP	3 IPS	228306	2.717	5.079	11.496	3.937	8.543	9.646
6"	IPS	4 IPS	228277	3.543	5.512	12.256	4.291	9.055	10.433
8" - TL *	IPS	2 IPS	228146	1.850	4.291	12.244	2.205	9.843	7.677
8" - TL *	DIP	2 IPS	228311	1.850	4.291	13.228	2.205	10.039	7.677
8" - TL *	IPS	3 IPS	288181	2.402	4.567	13.780	3.150	10.039	7.677
8" - TL *	DIP	3 IPS	228312	2.402	4.567	13.780	3.150	10.039	7.677
8"	IPS	4 IPS	228276	3.543	5.512	14.256	4.370	11.220	11.024
10" - 22" - TL *	IPS	2 IPS	228182	1.850	4.291	--	2.205	--	7.874
10" - 20" - TL *	DIP	2 IPS	228182	1.850	4.291	--	2.205	--	7.874
10" - 22" - TL *	IPS	3 IPS	228187	2.402	4.567	--	3.150	--	7.874
10" - 20" - TL *	DIP	3 IPS	228187	2.402	4.567	--	3.150	--	7.874

* FRIATEC Pneumatic Top-loading tool required

FRIATEC Safety Fittings can be fused to all PE pipes within melt index groups 003-050 and Pipe SDR Range 9.33 through 17.6. For Pipe SDR Range 21+, contact IPEX for **reduced** fusion times.
 PE pipes of different melt index groups can be joined.

Saddles con't

SPA Ballon Saddles



Short Designation VA, VA-TL d1./d2...
 Field of Application Installation of service and branch pipes
 Range of Application Gas up to 100 psi and water up to 160 psi
 For higher pressure ranges, contact IPEX at 800-463-9572

FRIATEC Molded Saddle Fittings may be clamped onto pipes up to SDR 9 and sealed using electrofusion. In addition to house connection fittings, FRIATEC Molded Saddle Fittings can also be used as branch saddles for polyethylene relining pipes (U-liners, C-liners, Roll-down)

Benefits include:

- universal compatibility with various diameters of polyethylene pipe from 3" up to 28"
- quick, easy and safe assembly



Nominal Pipe d1 (in)	Main Size d2	Product Code
3"	IPS	228236
4"	IPS	228237
4"	DIP	228301
6"	IPS	228238
6"	DIP	228308
8" - TL*	IPS	228239
10" - 12" TL*	IPS	228241

* FRIATEC Pneumatic Top-loading tool required

SPA Dust Cap

SPA Dust Cap protects against dirt and debris from entering the top portion of the SPA saddle.



Description	Product Code
Electrofusion Cap for SPA Saddles	228242

FRIATEC Safety fittings can be fused to all PE pipes within melt index groups 003-050 and SDR range 9.33 through 17.6. Assemble nipple, bushing or corporation stop into saddle using red LOCTITE #262 (SSPT) = Straight Standard Pipe Thread. The use of tapered fittings for the outlet is not permitted

Repair Patches and Clamps

For Pipe Repairs up to 28"

Short Designation VVS / VSC-TL d...

Field of Application Repair of small damage leakage
Reinforcement of "squeeze off" areas and areas with surface damage

Range of Application Gas up to 100 psi and water up to 160 psi

For higher pressure ranges, contact IPEX at 800-463-9572

If a pipe is damaged, FRIATEC Repair Patches and Clamps are the quick reliable way to make the repair.

FRIATEC pipe repair systems are both simple to use and effective for pipe repair up to 28". Our repair systems make use of existing FRIATEC technology to seal a pipe puncture.

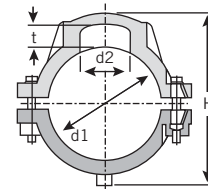

Repair Clamps - Under saddle

Nominal Pipe	Main Size	Product Code	d1	d2	H	t	Cold Zone Width (Center)
3"	IPS	228175	3.500	1.969	5.827	0.827	2.953"/75mm
4"	IPS	228176	4.500	1.969	6.614	0.827	3.071"/78mm
4"	DIP	228295	4.500	1.969	6.614	0.827	3.071"/78mm
6"	IPS	228177	6.625	1.969	8.583	0.827	3.346"/85mm
6"	DIP	228307	6.625	1.969	8.583	0.827	3.346"/85mm

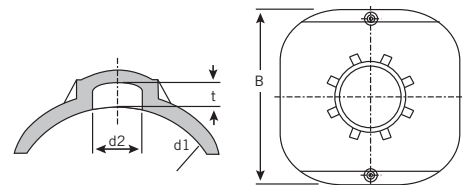

Repair Patches - Top Loading

Nominal Pipe (in)	Main Size	Product Code	d1	d2	t	B	Cold Zone Width (Center)
8"	IPS *	228178	8.625	1.969	0.827	10.157	3.268"/85mm
8"	DIP *	228310	9.050	1.969	0.827	11.142	3.268"/85mm
10" - 22"	IPS *	228179	10.750 - 28.000	1.969	0.787	7.874	3.307"/83mm
10" - 20"	DIP *		11.100 - 21.600				

* FRIATEC Pneumatic Top-loading tool required (restriction on 28")

FRIATEC Safety Fittings can be fused to all PE pipes within melt index groups 003-050 and Pipe SDR Range 9.33 through 17.6. For Pipe SDR Range 21+, contact IPEX for **reduced** fusion times.

Reference materials from IPEX

FRIATEC PE Electrofusion Water Brochure and Gas Brochure



Ads for FRIATEC PE Electrofusion Water and Gas

FRIATEC PE Electrofusion Price List



FRIATEC PE Electrofusion Multimedia Presentation



Contact your IPEX representative for more information or visit our websites.

SALES AND CUSTOMER SERVICE

Canadian Customers call IPEX Inc.

Toll free: (866) 473-9462

www.ipexinc.com

U.S. Customers call IPEX USA LLC

Toll free: (800) 463-9572

www.ipexamerica.com

About the IPEX Group of Companies

As leading suppliers of thermoplastic piping systems, the IPEX Group of Companies provides our customers with some of the largest and most comprehensive product lines. All IPEX products are backed by more than 50 years of experience. With state-of-the-art manufacturing facilities and distribution centers across North America, we have established a reputation for product innovation, quality, end-user focus and performance.

Markets served by IPEX group products are:

- Electrical systems
- Telecommunications and utility piping systems
- PVC, CPVC, PVCO, PP, ABS, PEX, FR-PVDF and PE pipe and fittings (1/4" to 48")
- Industrial process piping systems
- Municipal pressure and gravity piping systems
- Plumbing and mechanical piping systems
- PE Electrofusion systems for gas and water
- Industrial, plumbing and electrical cements
- Irrigation systems

Friatec® is manufactured by IPEX Inc. and FRIATEC AG is distributed in the United States by IPEX USA LLC.

Friatec® is a trademark of FRIATEC AG.

This literature is published in good faith and is believed to be reliable. However it does not represent and/or warrant in any manner the information and suggestions contained in this brochure. Data presented is the result of laboratory tests and field experience.

A policy of ongoing product improvement is maintained. This may result in modifications of features and/or specifications without notice.

