



APPLICATIONS

Specifically designed for:

- Small homes
- Camps
- Mobile homes

PUMP SPECIFICATIONS

- Pipe connections:
3/4" suction,
3/4" discharge
- Pressure switch: AS3FX

MOTOR SPECIFICATIONS

- NEMA standard
- 115/230V, 60 Hz
- Single phase
- 3500 RPM
- Built-in overload with automatic reset.
- Capacitor start type
- Stainless steel shaft
- 1/2 HP - see back ①

FEATURES

- **Self-Adjusting Capacity:** Automatically adjusts to the water demand within the pump's capacity. When one faucet is in use there's no change in the water flow when a second outlet is opened.
- **Compact:** Can be easily installed in locations where other larger pumps are difficult to install.
- **Tankless:** Self-contained water system, no separate tank required. Fresh water is always delivered directly from the well to the faucet.
- **Exclusive Air Handling Ability:** When pump is primed it never needs priming again even if the water level drops below the end of the suction pipe.

It resumes pumping as soon as the water level rises again. Gas or air in the water will not air-bind the pump.

- **Protected Mechanical Seal:** Water is retained in the casing so the seal can never run dry.
- **Easy to Service:** Pump has nozzle clean-out plug. Provides easy access to nozzle and diffuser for cleaning. Back pull-out design - pipes do not have to be disturbed.
- **Powered for Continuous Operation:** Pump ratings are within the motor manufacturer's recommended working limits, can be operated continuously without damage.
- **Corrosion Resistant:** Electro-coated paint process is applied inside and out, then is baked on.

SYSTEM COMPONENTS

- **Basic Pump Unit:** Includes pump, motor, pressure switch, tubing and fittings, air volume control valve, suction check valve, nozzle and diffuser.

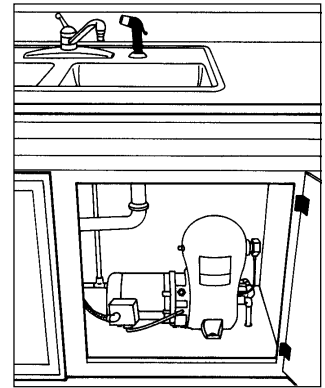

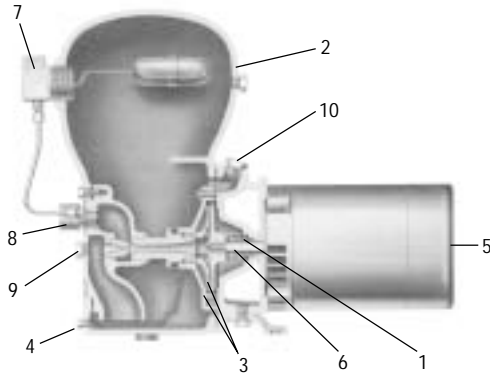

FEATURES

1. Mechanical Seal
2. Rugged Cast Iron Construction
3. Corrosion Resistant Impeller and Guide Vane
4. Drain Plug
5. Two-Compartment Motor
6. Stainless Steel Shaft
7. Built-In Air Volume Control
8. Built-In Check Valve
9. Nozzle Clean-Out Plug
10. Priming Plug

DIMENSIONS AND WEIGHTS

(All dimensions in inches and weight in lbs.) (Do not use for construction purposes.)

HP/Model	① 1/2 HP - BF03S
Weight	69
Length	20
Width	10 1/2
Height	15

PERFORMANCE RATINGS

HP/Model	① 1/2 HP - BF03S		
Shallow Well Pkg.	None Required		
Adapter	Built-In		
Nozzle	AN015		
Venturi (Diffuser)	4K5		
Total Suction Lift (Feet)	Discharge Pressure (PSI)		Maximum Shut-Off (PSI)
	20	30	
	Gallons Per Hour		
5	525	380	51
10	480	330	49
15	410	290	46
20	350	255	44
25	265	220	42

① Pump now uses a 1/2 HP motor due to 1/3 HP motors being obsolete.