

**Z554**

9 [229] MEDIUM-DUTY DRAIN WITH SUR-SET BUCKET

SPECIFICATION SHEET

TAG \_\_\_\_\_

Dimensional Data (inches and [ mm ]) are Subject to Manufacturing Tolerances and Change Without Notice

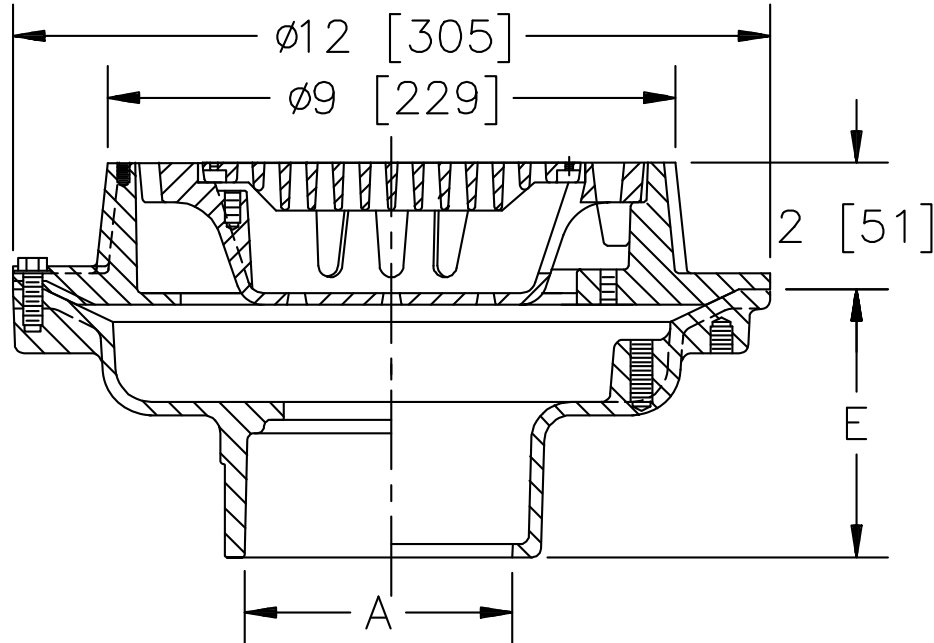

A - Pipe Size Inches [mm]	Approx. Wt. Lbs. [kg]	Grate Open Area Sq. In. [cm <sup>2</sup> ]
2, 3, 4 [51, 76, 102]	21 [10]	9 [58]

**ENGINEERING SPECIFICATION: ZURN Z554**

9" [229mm] Diameter top drain, Dura-Coated cast iron body with bottom outlet, seepage pan and combination membrane flashing clamp and frame and medium-duty cast iron grate with sur-set bucket.

**OPTIONS** (Check/specify appropriate options)**PIPE SIZE**(Specify size/type) **OUTLET****'E' BODY HT. DIM.**

4 [102]

\_\_\_ IP Threaded

2-3/4 [70]

2, 3, 4 [51, 76, 102]

\_\_\_ NH No-Hub

4-3/4 [121]

2, 3, 4 [51, 76, 102]

\_\_\_ NL Neo-Loc

3-1/2 [89]

**PREFIXES**

- \_\_\_ Z D.C.C.I. Body and Top\*
- \_\_\_ ZB D.C.C.I. Body with Polished Bronze Top (Add 3/16 [5] to 2 [51] Dim. & 3/4 [20] to 9 [229] Dim.)
- \_\_\_ ZN D.C.C.I. Body with Polished Nickel Bronze Top (Add 3/16 [5] to 2 [51] Dim. & 3/4 [20] to 9 [229] Dim.)

**SUFFIXES**

- \_\_\_ -AR Acid Resisting Epoxy Coated Cast Iron
- \_\_\_ -G Galvanized Cast Iron
- \_\_\_ -P Trap Primer Connection
- \_\_\_ -TC Neo-Loc Test Cap Gasket  
(2, 3, 4 [51, 76, 102] NL Bottom Outlet Only)
- \_\_\_ -TS Top Secured with Slotted Screws
- \_\_\_ -VP Vandal-Proof Secured Top

\* Regularly furnished unless otherwise specified.

Zurn Industries, LLC | Specification Drainage Operation  
 1801 Pittsburgh Avenue, Erie, PA U.S.A. 16502 · Ph. 855-663-9876, Fax 814-454-7929  
 In Canada | Zurn Industries Limited  
 3544 Nashua Drive, Mississauga, Ontario L4V 1L2 · Ph. 905-405-8272, Fax 905-405-1292  
[www.zurn.com](http://www.zurn.com)

Rev. E  
 Date: 09/27/2017  
 C.N. No. 137917  
 Prod. | Dwg. No. Z554