

DOMESTIC

NON-DOMESTIC

SUBMITTAL: C110 MECHANICAL JOINT PRODUCT

[\(Current revisions for the noted Standards apply\)](#)

- SIZES:** 2" - 48"
- STANDARDS:** ANSI/AWWA C110/A21.10, NFPA 13/24, 3" - 12" UL listed and approved (File - Tyler Union)
- MATERIAL:** Cast of ASTM A536 qualified ductile iron. Date code is cast on and required for traceability.
- PRESSURE RATING:** *Flanged fittings rated at 250 psi. Mechanical joints 2" - 24" rated at 350 psi and 30" - 48" at 250 psi.
*Note: With rubber annular ring flange gasket, 2" - 24" Flanged fittings can be rated at 350 psi.
Note: Wyes over 12" are not pressure rated. Contact Tyler Union for rating in your application.
- DEFLECTION:** Joint deflection 5° max for 2"- 12" and 3° max for 14"- 48". Reduces by 50% at nominal pipe & fitting diameters
- NSF-61 & NSF372:** Meets all requirements including Annex G, Tyler Union's Underwriters Laboratory listing MH16439.
- ASPHALT COATING:** Per ANSI/AWWA C104/A21.4 and ANSI/AWWA C110/A21.10.
- CEMENT LINING:** Per ANSI/AWWA C104/A21.4, with double cement lining available upon request.
- EPOXY COATING:** Fusion bonded epoxy per ANSI/AWWA C116/A21.16. Additional coatings available upon request.
- BARE FITTINGS:** Available upon request.
- FASTNERS:** High strength low alloy weathering steel per ANSI/AWWA C111/A21.11 and ASTM A242
- INSTALLATION:** Install per AWWA C600/C651 using pipe conforming to ANSI/AWWA C151/A21.51 or AWWA C900/905.

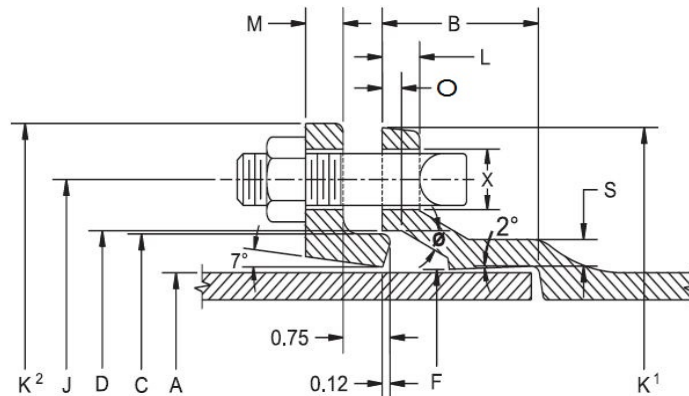

NOMINAL JOINT DIMENSIONS IN INCHES

Size Inches	A Dia. DI Pipe	B Hub Depth	C Dia. GLAND	D Dia.	F Dia.	Ø	X	J Dia. GLAND	K ¹ Dia.	K ² Dia. GLAND	L	M GLAND	O	S	Qty. BOLTS
2	2.51	2.50	3.39	3.50	2.61	28°	3/4	4.75	6.25	6.25	0.73	0.62	0.31	0.44	2
3	3.96	2.50	4.84	4.94	4.06	28°	3/4	6.19	7.69	7.69	0.94	0.62	0.31	0.52	4
4	4.80	2.50	5.92	6.02	4.90	28°	7/8	7.50	9.12	9.12	1.00	0.75	0.31	0.65	4
6	6.90	2.50	8.02	8.12	7.00	28°	7/8	9.50	11.12	11.12	1.06	0.88	0.31	0.70	6
8	9.05	2.50	10.17	10.27	9.15	28°	7/8	11.75	13.37	13.37	1.12	1.00	0.31	0.75	6
10	11.10	2.50	12.22	12.34	11.20	28°	7/8	14.00	15.69	15.62	1.19	1.00	0.31	0.80	8
12	13.20	2.50	14.32	14.44	13.30	28°	7/8	16.25	17.94	17.88	1.25	1.00	0.31	0.85	8
14	15.30	3.50	16.40	16.54	15.44	28°	7/8	18.75	20.31	20.25	1.31	1.25	0.31	0.89	10
16	17.40	3.50	18.50	18.64	17.54	28°	7/8	21.00	22.56	22.50	1.38	1.31	0.31	0.97	12
18	19.50	3.50	20.60	20.74	19.64	28°	7/8	23.25	24.83	24.75	1.44	1.38	0.31	1.05	12
20	21.60	3.50	22.70	22.84	21.74	28°	7/8	25.50	27.08	27.00	1.56	1.44	0.31	1.12	14
24	25.80	3.50	26.90	27.04	25.94	28°	7/8	30.00	31.58	31.50	1.62	1.56	0.31	1.22	16
30	32.00	4.00	33.29	33.46	32.17	20°	1-1/8	36.88	39.12	39.12	1.81	2.00	0.38	1.50	20
36	38.30	4.00	39.59	39.76	38.47	20°	1-1/8	43.75	46.00	46.00	2.00	2.00	0.38	1.80	24
42	44.50	4.00	45.79	45.96	44.67	20°	1-3/8	50.62	53.12	53.12	2.00	2.00	0.38	1.95	28
48	50.80	4.00	52.09	52.26	50.97	20°	1-3/8	57.50	60.00	60.00	2.00	2.00	0.38	2.20	32

C110 DUCTILE IRON FULL BODY FITTINGS

SAMPLE SPECIFICATIONS

(Current ANSI/AWWA revisions apply)

Mechanical joint watermain fittings with accessories 2" through 48" shall be manufactured from ductile iron in accordance with and meet all applicable terms and provisions of standards ANSI/AWWA C110/A21.10 and ANSI/AWWA C111/A21.11. Ductile iron mechanical joint fittings 2" through 24" shall be rated for 350 psi working pressure. All ductile iron mechanical joint fittings 30" through 48" shall be rated for 250 psi working pressure. Flanged ductile iron fittings in 24" (610 mm) and smaller sizes may be rated for 350 psi (2,413 kPa) with the use of special (annular ring or comparable) gaskets.

NOTE: EXCEPTIONS: Mechanical joint fittings with flanged branches and 14" and larger caps and plugs are rated for water pressure of 250 PSI.

NOTE: Installation per AWWA C600 and AWWA C651, current revision.

NOTE: Fittings are cement lined and seal coated in accordance with ANSI/AWWA C104/A21.4. Fittings are also available double cement lined, bare or epoxy coated. Coated and lined fittings meet requirements of NSF-61, NSF-372 & Annex G.

Nominal Joint Dimensions in Inches																
Size	A	B	C	D	F	θ	X	J	K1	K2	L	M	N	O	S	
*2	2.50	2.50	3.39	3.50	2.61	28°	3/4	4.75	6.25	6.25	0.75	0.62	1.12	0.31	0.44	
3	3.96	2.50	4.84	4.94	4.06	28°	3/4	6.19	7.69	7.69	0.94	0.62	1.37	0.31	0.52	
4	4.80	2.50	5.92	6.02	4.90	28°	7/8	7.50	9.12	9.12	1.00	0.75	1.50	0.31	0.65	
6	6.90	2.50	8.02	8.12	7.00	28°	7/8	9.50	11.12	11.12	1.06	0.88	1.63	0.31	0.70	
8	9.05	2.50	10.17	10.27	9.15	28°	7/8	11.75	13.37	13.37	1.12	1.00	1.75	0.31	0.75	
10	11.10	2.50	12.22	12.34	11.20	28°	7/8	14.00	15.69	15.62	1.19	1.00	1.75	0.31	0.80	
12	13.20	2.50	14.32	14.44	13.30	28°	7/8	16.25	17.94	17.88	1.25	1.00	1.75	0.31	0.85	
14	15.30	3.50	16.40	16.54	15.44	28°	7/8	18.75	20.31	20.25	1.31	1.25	2.00	0.31	0.89	
16	17.40	3.50	18.50	18.64	17.54	28°	7/8	21.00	22.56	22.50	1.38	1.31	2.06	0.31	0.97	
18	19.50	3.50	20.60	20.74	19.64	28°	7/8	23.25	24.83	24.75	1.44	1.38	2.13	0.31	1.05	
20	21.60	3.50	22.70	22.84	21.74	28°	7/8	25.50	27.08	27.00	1.50	1.44	2.19	0.31	1.12	
24	25.80	3.50	26.90	27.04	25.94	28°	7/8	30.00	31.58	31.50	1.62	1.56	2.31	0.31	1.22	
30	32.00	4.00	33.29	33.46	32.17	20°	1 1/8	36.88	39.12	39.12	1.81	2.00	2.75	0.38	1.50	
36	38.30	4.00	39.59	39.76	38.47	20°	1 1/8	43.75	46.00	46.00	2.00	2.00	2.75	0.38	1.80	
42	44.50	4.00	45.79	45.96	44.67	20°	1 3/8	50.62	53.12	53.12	2.00	2.00	2.75	0.38	1.95	
48	50.80	4.00	52.09	52.26	50.97	20°	1 3/8	57.50	60.00	60.00	2.00	2.00	2.75	0.38	2.20	

*Not included in AWWA C110.

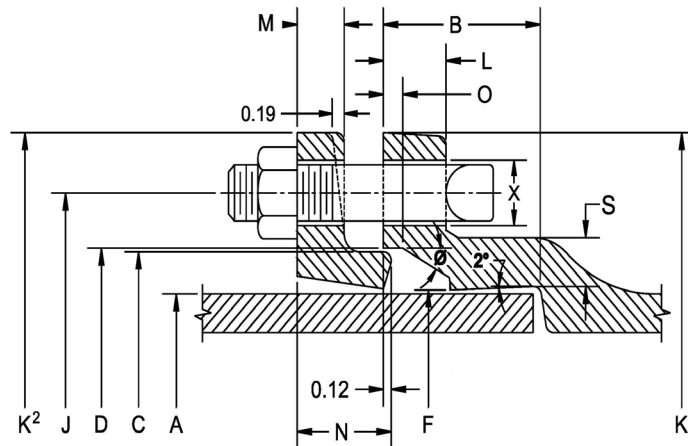

ANSI/AWWA C110 Mechanical Joint Fittings



C110 DUCTILE IRON FULL BODY FITTINGS

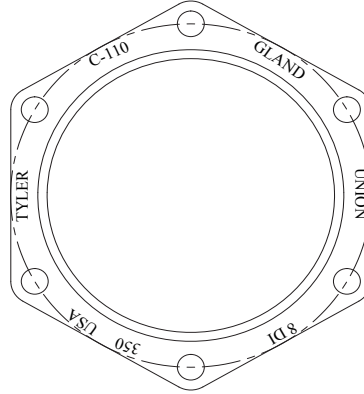
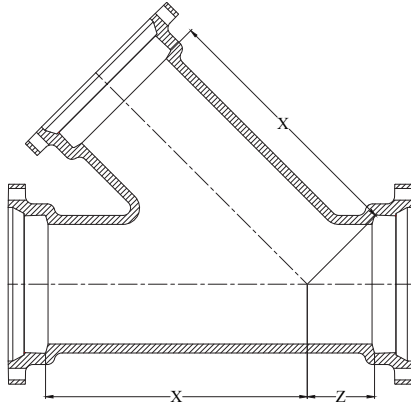

WYES / LATERALS				
Size		Dimensions		Weight
Run	Branch	X	Z	
3	3	10.00	3.00	60
4	4	12.00	3.00	90
6	4	14.50	3.50	130
6	6	14.50	3.50	145
8	4	17.50	4.50	190
8	6	17.50	4.50	205
8	8	17.50	4.50	230
10	6	20.50	5.00	330
10	8	20.50	5.00	310
10	10	20.50	5.50	435
12	8	24.50	5.50	505
12	12	24.50	5.50	490
14	6	27.00	6.00	626
16	16	30.00	6.50	1079
18	8	32.00	7.00	1073
18	10	32.00	7.00	975
18	12	32.00	7.00	1015
18	16	32.00	7.00	1135
18	18	32.00	7.00	1130
20	10	35.00	8.00	1220
20	12	35.00	8.00	1260
20	16	35.00	8.00	1375
20	20	35.00	8.00	1525
24	24	40.50	9.00	2372
30	30	49.00	10.00	3670
36	24	54.00	15.00	5390
36	36	60.00	19.50	6335
42	24	60.00	12.00	6810
42	30	63.00	12.00	7210
42	36	66.00	12.00	8355
42	42	71.00	15.00	9900
48	48	77.00	16.00	13150

* Not included in AWWA C-110.

MJ GLANDS	
Size	Weight
2	3
3	4
4	6
6	10
8	16
10	19
12	26
14	34
16	54
18	52
20	73
24	91
30	90
36	127
42	279
48	341

MJ ACCESSORY KITS AND WEIGHTS						
size	No.	Bolt Size	Bolt Length	Bolt Torque ft/lbs	Wt. of Gland, Bolts and Gasket	Pipe Barrel O.D.
*2	2	5/8	3	45-60	5	2.50
3	4	5/8	3	45-60	7	3.96
4	4	3/4	3 1/2	75-90	10	4.80
6	6	3/4	3 1/2	75-90	16	6.90
8	6	3/4	4	75-90	25	9.05
10	8	3/4	4	75-90	30	11.10
12	8	3/4	4	75-90	40	13.20
14	10	3/4	4 1/2	75-90	45	15.30
16	12	3/4	4 1/2	75-90	55	17.40
18	12	3/4	4 1/2	75-90	65	19.50
20	14	3/4	4 1/2	75-90	85	21.60
24	16	3/4	5	75-90	105	25.80
30	20	1	6	100-120	220	32.00
36	24	1	6	100-120	301	38.30
42	28	1 1/4	6 1/2	120-150	389	44.50
48	32	1 1/4	6 1/2	120-150	477	50.80