

Q345A, Q348A, Q348B, Q362A, Q373A and Q381A Pilot Burner/Igniter-Sensors

Application

These pilot burner/igniter-sensors provide pilot flame ignition and sensing in intermittent pilot systems. They consist of a target type pilot burner with a combination spark igniter and flame sensor mounted in place of the thermocouple.

Installation

WHEN INSTALLING THIS PRODUCT...

1. Read these instructions carefully. Failure to follow instructions can damage product or cause a hazardous condition.

2. Check ratings given in instructions and on product to make sure product is suitable for your application.

3. Make sure installer is a trained, experienced service technician.

4. After completing installation, use these instructions to check out product operation.

⚠ WARNING

**FIRE OR EXPLOSION HAZARD
CAN CAUSE PROPERTY DAMAGE,
SEVERE INJURY, OR DEATH.**

Follow these warnings exactly:

1. Disconnect power supply before wiring to prevent electrical shock or equipment damage.
2. To avoid dangerous accumulation of fuel gas, turn off gas supply at appliance service valve before starting installation and perform Gas Leak Test after completion of installation.
3. Do not bend pilot tubing at the control or pilot after compression nut has been tightened. Gas leakage at the connection may result.

Follow appliance manufacturer instructions if available; otherwise, use instructions provided below.

LOCATION

1. Position pilot burner/igniter-sensor for easy access and observation. In replacement applications, replace pilot burner/igniter-sensor with an identical unit and position new pilot burner/igniter-sensor in the same location and orientation as the original one.

Fig. 1—Mount pilot burner/igniter-sensor on main burner.

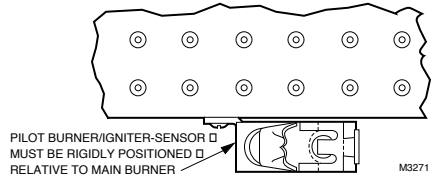
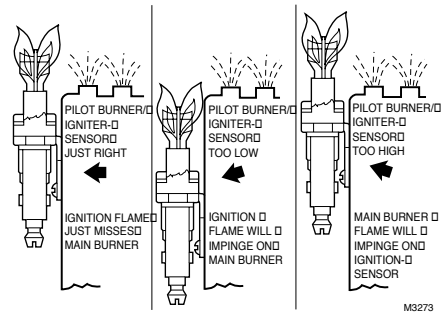

Fig. 2—Location of pilot burner/igniter-sensor.



2. Mount pilot burner/igniter-sensor on main burner. Mounting surfaces other than the main burner may shift, bend, or warp as furnace expands and contracts while operating. See Fig. 1.

3. Mount pilot burner/igniter-sensor so the pilot flame remains properly positioned with respect to the main burner flame. See Fig. 2.

4. Supply pilot flame with ample air free of combustion products.

5. Do not impinge pilot flame on adjacent parts. Do not impinge main burner flame on pilot burner/igniter-sensor.

6. Do not expose pilot flame to falling scale, which could impair main burner ignition.

7. Do not expose pilot burner/igniter-sensor to main burner rollout while igniting or extinguishing.

8. Do not expose pilot flame to drafts that push or pull pilot flame away from the igniter-sensor.

NOTE: The Q381A Pilot Burner/Igniter-Sensor is for horizontal mounting only. Mounting bracket must remain vertical.

CONNECT PILOT GAS TUBING

1. Cut tubing to desired length and bend as necessary for routing to pilot burner/igniter-sensor. Do not make sharp bends or deform tubing. Do not bend tubing at control after compression nut has been tightened because this can result in gas leakage at connection.

2. Square off and remove burrs from end of tubing.

3. Push tubing into compression nut clearance hole until tubing bottoms.

NOTE: When replacing a control, cut off old compression fitting and replace with new compression fitting provided with new pilot burner. Never use old compression fitting because it may not provide a gas-tight seal. See Fig. 3.

Fig. 3—Always use new compression fitting.

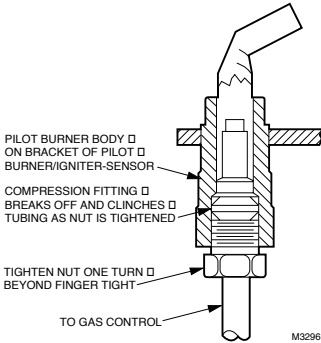

4. While holding tubing all the way in, engage threads and turn until finger tight.

5. Using a wrench, turn compression nut one turn beyond finger tight. *Do not overtighten.*

6. Connect other end of tubing to gas control according to gas control manufacturer instructions.

WIRE IGNITER-SENSOR

The igniter-sensor must be mounted on the burner. Connect the control module ground wire to one of the igniter-sensor mounting screws to complete the system grounding.

Connect ground wire as follows:

1. Use 221° F [105° C] minimum thermoplastic-insulated wire for the ground leadwire (asbestos insulation is not acceptable).

2. A male 1/4 in. [6 mm] quick-connect terminal is provided on Honeywell ignition modules. Fasten female quick-connect to wire end at ignition module.

3. Strip other end and fasten under igniter-sensor mounting screw.

4. If necessary, use shield to protect lead from radiant heat of burner.

5. The pilot burner serves as the grounding area for the flame signal. Run lead from pilot burner to the common ground selected.

Connect the ignition cable as follows:

1. The high tension ignition cable must conform to applicable local or national standards.

2. Connect one end of the ignition cable to stud terminal on igniter-sensor using 1/4 in. [6 mm] diameter snap-spring or cage-clips on cable ends.

3. Connect the other end of the ignition cable to the igniter terminal on ignition module.

4. Use ceramic or plastic standoff insulators as necessary to prevent cable from contacting metal surfaces.

INSTALL BLEED GAS TUBE (optional)

1. Route bleed tube from bleed tap on gas control to the pilot burner/igniter-sensor.

2. Push clip into place. See Fig. 4.

3. Insert bleed gas tube until 3/8 in. [10 mm] to tubing is above pilot burner/igniter-sensor bracket. Tip of bleed gas tube must not extend into pilot flame.

Fig. 4—Install bleed gas tube.

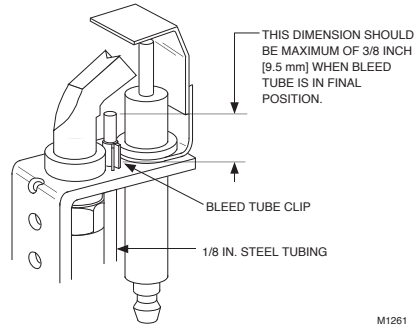

Startup and Checkout

PERFORM GAS LEAK TEST



WARNING

**FIRE OR EXPLOSION HAZARD
CAN CAUSE PROPERTY DAMAGE,
SEVERE INJURY, OR DEATH.**

Check for gas leaks with soap and water solution any time work is done on a gas system.

Gas Leak Test:

1. Ensure that gas supply is turned on at the appliance service valve.

2. Paint pipe connections upstream of pilot burner with rich soap and water solution. Bubbles indicate gas leak.

3. If leak is detected, tighten pipe connections.

4. Set thermostat to call for heat to light main burner.

5. With main burner in operation, paint pipe joints (including adapters) and gas control inlet and outlet with rich soap and water solution.

6. If another leak is detected, tighten adapter screws, joints, and pipe connections.

7. Replace part if leak cannot be stopped.

Fig. 5—Igniter-sensor tip must be in pilot flame.

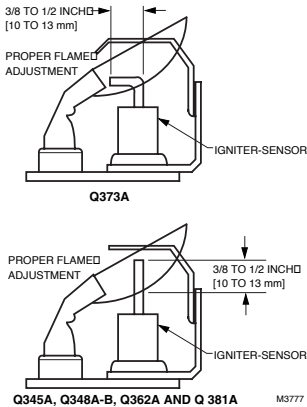
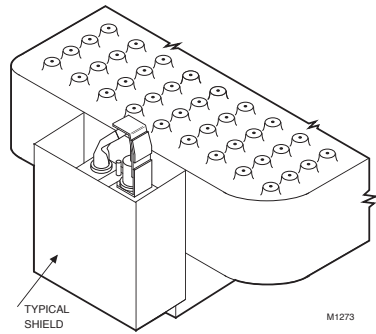

Fig. 6—Proper shielding of pilot flame.



ADJUST PILOT FLAME

The pilot flame should envelop 3/8 to 1/2 in. [10 to 13 mm] of the igniter-sensor tip. See Fig. 5. To adjust pilot flame:

1. Turn off system by setting thermostat below temperature to call for heat.
2. Disconnect lead to MV terminal on gas control.
3. Light pilot by setting thermostat to call for heat.
4. Remove pilot adjustment cover screw from gas control.
5. Turn inner pilot adjustment screw clockwise to decrease or counterclockwise to increase pilot flame.
6. Always replace pilot adjustment cover screw and tighten firmly after completing adjustment to assure pro-per operation.

Service

⚠ WARNING

**FIRE OR EXPLOSION HAZARD
CAN CAUSE PROPERTY DAMAGE,
SEVERE INJURY, OR DEATH.**









Perform Gas Leak Test anytime work is done to the system.

PILOT OUTAGE

1. If pilot flame goes out during ignition, but is pro-perly adjusted, recheck mounting and location instructions in Location section.
2. Refer to ignition module instructions to check wiring between igniter-sensor and ignition module or between gas control and ignition module.
3. If all mounting and location instructions are followed but pilot continues to go out, construct shielding to protect pilot flame from main burner ignition and extinction and drafts. See Fig. 6.
4. Check pilot and main burner lightoff.

- Set the thermostat to call for heat.
- Watch the pilot burner during the ignition sequence. See if:
 - Ignition spark continues after the pilot is lit.
 - The pilot lights and the spark stops, but main burner does not light.
 - S860B,H; S86H only: The pilot lights, the spark stops and main burner lights, but the system locks out.
- If so, assure adequate flame current as follows:
 - Turn off furnace at circuit breaker or fuse box.
 - Clean the flame rod with emery cloth.
 - Make sure electrical connections are clean and tight. Replace damaged wire with moisture-resistant no. 18 wire rated for continuous duty up to 221° F [105° C].
 - Check for cracked ceramic insulator, which can cause short to ground, and replace pilot burner/igniter-sensor if necessary.
 - At the gas control, disconnect main valve wire from the TH or MV terminal.
 - Turn on power and set thermostat to call for heat. The pilot should light but the main burner will remain off because the main valve actuator is disconnected.
 - Check the pilot flame. Make sure it is blue, steady and envelops 3/8 to 1/2 in. [10 to 13 mm] of the flame rod. See Fig. 7 for possible flame problems and their causes.
 - If necessary, adjust pilot flame by turning the pilot adjustment screw on the gas control clockwise to decrease or counterclockwise to increase pilot flame. After adjustment, always replace pilot adjustment cover screw and tighten firmly to assure proper gas control operation.
 - Set thermostat below room temperature to end call for heat.
- Recheck ignition sequence as follows:
 - Reconnect main valve wire.
 - Set thermostat to call for heat.
 - Watch ignition sequence at burner.
 - If spark still does not stop after pilot lights, replace ignition module.
 - If main burner does not light or if main burner lights but system locks out, check module, ground wire, and gas control as described in control module instructions.

Fig. 7—Example of unsatisfactory pilot flames.

APPEARANCE	APPEARANCE	CAUSE
SMALL BLUE FLAME 	SMALL BLUE FLAME 	CHECK FOR LACK OF GAS FROM: <ul style="list-style-type: none"> • CLOGGED ORIFICE FILTER • CLOGGED PILOT FILTER • LOW GAS SUPPLY PRESSURE • PILOT ADJUSTMENT AT MINIMUM
LAZY YELLOW FLAME 	LAZY YELLOW FLAME 	CHECK FOR LACK OF AIR FROM: <ul style="list-style-type: none"> • DIRTY ORIFICE • DIRTY LINT SCREEN, IF USED • DIRTY PRIMARY AIR OPENING, □ IF THERE IS ONE • PILOT ADJUSTMENT AT MINIMUM
WAVING BLUE FLAME 	WAVING BLUE FLAME 	CHECK FOR: <ul style="list-style-type: none"> • EXCESSIVE DRAFT AT PILOT □ LOCATION • RECIRCULATING PRODUCTS OF COMBUSTION
NOISY LIFTING BLOWING FLAME 	NOISY LIFTING BLOWING FLAME 	CHECK FOR: <ul style="list-style-type: none"> • HIGH GAS PRESSURE
HARD SHARP FLAME 	HARD SHARP FLAME 	THIS FLAME IS CHARACTERISTIC OF MANUFACTURED GAS CHECK FOR: <ul style="list-style-type: none"> • HIGH GAS PRESSURE • ORIFICE TOO SMALL

M3778

CHECK IGNITION CABLE

1. Assure that ignition cable is not in contact with metal surfaces.
2. Assure that ignition cable is not more than 3 feet [1 m] long.
3. Assure connections to the ignition module stud terminal and the igniter-sensor are clean and tight.
4. Check electrical continuity of ignition cable.

CHECK GROUNDING

1. If ground is poor or erratic, safety shutdown will occur. Therefore, if nuisance shutdowns are reported, check the ground precautions in Wire Igniter-Sensor section.

2. If leadwire is damaged or deteriorated, use no. 14 to 18 gauge, moisture-resistant, thermoplastic, insulated wire with 221° F [105° C] minimum rating as replacement.
3. Excessive temperature at the ceramic flame rod insulator will permit electrical leakage to ground.
 - a. If bracket is bent, bend it back to correct position.
 - b. If insulator is cracked, replace pilot burner/igniter-sensor.

TEST SAFETY LOCKOUT

- Refer to appliance manufacturer instructions to test for proper safety lockout times.

Honeywell

Helping You Control Your World

Home and Building Control
 Honeywell Inc.
 1985 Douglas Drive North
 Golden Valley, Minnesota 55422

Home and Building Control
 Honeywell Limited—Honeywell Limitée
 740 Ellesmere Road
 Scarborough, Ontario
 M1P 2V9

