

INSTALLATION AND SERVICE MANUAL

oil-fired unit heaters

model POR



FOR YOUR SAFETY

The use and storage of gasoline or other flammable vapors and liquids in open containers in the vicinity of this appliance is hazardous.

⚠ WARNING

Improper installation, adjustment, alteration, service or maintenance can cause property damage, injury or death, and could cause exposure to substances which have been determined by various state agencies to cause cancer, birth defects or other reproductive harm. Read the installation, operating and maintenance instructions thoroughly before installing or servicing this equipment.

⚠ CAUTION

To prevent premature heat exchanger failure do not locate ANY gas-fired units in areas where chlorinated, halogenated or acid vapors are present in the atmosphere.

FOR YOUR SAFETY

WHAT TO DO IF YOU SMELL GAS:

1. Open windows.
2. Do not try to light any appliance.
3. Do not touch any electrical switch; do not use any phone in your building.
4. Immediately call your gas supplier.

IMPORTANT

The use of this manual is specifically intended for a qualified installation and service agency. All installation and service of these units must be performed by a qualified installation and service agency.

Inspection on Arrival

1. Inspect unit upon arrival. In case of damage, report immediately to transportation company and you local Modine sales representative.
2. Check rating plate on unit and motor to verify that power supply and motor specification requirements meet available electric power at the point of installation.
3. Inspect unit received for conformance with description of product ordered (including specifications where applicable).

SPECIAL PRECAUTIONS / TABLE OF CONTENTS

SPECIAL PRECAUTIONS

THE INSTALLATION AND MAINTENANCE INSTRUCTIONS IN THIS MANUAL MUST BE FOLLOWED TO PROVIDE SAFE, EFFICIENT AND TROUBLE-FREE OPERATION. IN ADDITION, PARTICULAR CARE MUST BE EXERCISED REGARDING THE SPECIAL PRECAUTIONS LISTED BELOW. FAILURE TO PROPERLY ADDRESS THESE CRITICAL AREAS COULD RESULT IN PROPERTY DAMAGE OR LOSS, PERSONAL INJURY, OR DEATH. THESE INSTRUCTIONS ARE SUBJECT TO ANY MORE RESTRICTIVE LOCAL OR NATIONAL CODES.

HAZARD INTENSITY LEVELS

1. **DANGER:** Indicates an imminently hazardous situation which, if not avoided, WILL result in death or serious injury.
2. **WARNING:** Indicates a potentially hazardous situation which, if not avoided, COULD result in death or serious injury.
3. **CAUTION:** Indicates a potentially hazardous situation which, if not avoided, MAY result in minor or moderate injury.
4. **IMPORTANT:** Indicates a situation which, if not avoided, MAY result in a potential safety concern.

DANGER

Appliances must not be installed where they may be exposed to a potentially explosive or flammable atmosphere.

WARNING

1. Disconnect power supply before making wiring connections to prevent electrical shock and equipment damage.
2. All appliances must be wired strictly in accordance with wiring diagram furnished with the appliance. Any wiring different from the wiring diagram could result in a hazard to persons and property.
3. Any original factory wiring that requires replacement must be replaced with wiring material having a temperature rating of at least 105°C.
4. When servicing or repairing this equipment, use only factory-approved service replacement parts. A complete replacement parts list may be obtained by contacting Modine Manufacturing Company. Refer to the rating plate on the appliance for complete appliance model number, serial number, and company address. Any substitution of parts or controls not approved by the factory will be at the owner's risk.

CAUTION

1. Do not locate units in tightly sealed rooms or small compartments (commonly referred to as confined spaces) without provisions for adequate combustion air and venting. Combustion air must have access to the confined space through a minimum of two permanent openings in the enclosure, at least one near the bottom. They should provide a free area of not less than one square inch per 1,000 BTU/Hr input rating of all units in the enclosure with a minimum of 100 square inches for each opening, whichever is greater.
2. When oil-fired unit heaters are to be installed in areas having negative pressure (for example - a space with exhaust fan(s)) a power venter is recommended.
3. Do not install units below 7 feet, measured from the bottom of the unit to the floor, unless properly guarded to provide protection from moving parts.

CAUTION

4. Do not install unit heater or vent pipe closer than 18 inches to combustible materials in any direction, except the front of the unit heater, which must be unobstructed.
5. A barometric draft control must be installed on each unit heater, in the same space as the unit heater and as close to the unit as possible. See Figure 5.1.
6. Remove bypass plug from fuel unit when unit is connected to one pipe oil system. Failure to do so will permanently damage fuel unit and void warranty.
7. Do not mount the OSV more than three feet above the burner inlet or above the lowest point in fuel line pipings between burner and OSV. In-line mounting is recommended.
8. Start-up and adjustment procedures should be performed by a qualified oil serviceman.
9. Do not reset primary control if heat exchanger is hot. If unit fails to operate properly after resetting twice, consult qualified oil serviceman.
10. Never use a nozzle size or type other than specified in Service Instructions.
11. Do not attempt to start the burner when excess oil has accumulated in the combustion chamber, when the heat exchanger is full of oil vapor or very hot.
12. Burner adjustments should only be performed by qualified oil serviceman.
13. Do not reset primary control if heat exchanger is warm. Wait till cool.
14. To prevent unusual thermal stress and eventual harm to the heat exchanger, do not operate unit heater without fire pot or with a damaged fire pot that does not enclose the flame.
15. Do not attempt to reuse any mechanical or electrical controllers which have been wet. Replace defective controller.

IMPORTANT

1. To prevent premature heat exchanger failure, do not locate ANY gas-fired appliances in areas where corrosive vapors (i.e. chlorinated, halogenated or acid) are present in the atmosphere.
2. To check most of the Possible Remedies in the troubleshooting guide listed in Table 18.1, refer to the applicable sections of the manual.

Table of Contents

Inspection on Arrival	1
Special Precautions	2
SI (Metric) Conversion Factors	3
Unit Location	3
Installation	4
Operation	11
Service Instructions	14
Dimensional/Performance Data	17
Service & Troubleshooting	18
Warranty	Back Page

SI (METRIC) CONVERSION FACTORS / UNIT LOCATION

SI (METRIC) CONVERSION FACTORS

Table 3.1

To Convert	Multiply By	To Obtain
"W.C. (inches water column)	0.24	kPa
psig	6.893	kpa
°F	$(°F-32) \times 0.555$	°C
inches	25.4	mm
feet	0.305	meters
CFM	0.028	m ³ /min
CFH	1.699	m ³ /min
btu/ft ³	0.0374	mJ/m ³
pound	0.453	kg
btu/hr	0.000293	kW/hr
gallons	3.785	liters

GENERAL INFORMATION

Install and wiring of these oil-fired unit heaters must conform to all applicable local codes, the National Electric Code, and NFPA No. 31 "Installation of Oil Burning Equipment" by the National Fire Protection Association. Installation of these unit heaters should only be performed by a qualified oil serviceman.

1. These unit heaters are listed by Underwriters Laboratories, Inc., with components as furnished.
2. Fuel oil grade No. 1 or 2, with a flash point not less than 100°F, is approved for these unit heaters as specified by (ASTM) D396-73 Standard Specification for Fuel Oils, or the Canadian Government Specification Board, 3-GP-28, (American Society for Testing and Materials).

UNIT LOCATION

DANGER

Appliances must not be installed where they may be exposed to potentially explosive or flammable atmosphere.

CAUTION

1. Do not locate units in tightly sealed rooms or small compartments (commonly referred to as confined spaces) without provisions for adequate combustion air and venting. Combustion air must have access to the confined space through a minimum of two permanent openings in the enclosure, at least one near the bottom. They should provide a free area of not less than one square inch per 1,000 BTU/Hr input rating of all units in the enclosure with a minimum of 100 square inches for each opening, whichever is greater.
2. When oil-fired unit heaters are to be installed in areas having negative pressure (for example - a space with exhaust fan(s)) a power venter is recommended.

IMPORTANT

To prevent premature heat exchanger failure, do not locate ANY gas-fired appliances in areas where corrosive vapors (i.e. chlorinated, halogenated or acid) are present in the atmosphere.

Location Recommendations

1. When location the furnace, consider general space and heating requirements, availability of gas and electrical supply, and proximity to vent locations.
2. Unit heaters should be located so they discharge air nearly parallel to exposed walls. Arrange units so they do not blow directly at occupants. Interference of air streams by columns, beams, partitions, or other obstructions should be avoided as much as possible.
3. In multiple unit installations, arrange units so that each supports the air stream of the next unit, thus creating circulatory air movement in the area. See Figure 3.1. A large portion of the heated air should be directed toward the side of the building exposed to prevailing winds.
4. When locating units, it is important to consider that the exhaust vent piping must be connected to the outside atmosphere.
5. Be sure the structural support at the unit location site is adequate to support the weight of the unit. For proper operation the unit must be installed in a level horizontal position.
6. Do not install units in locations where the flue products can be drawn into the adjacent building openings such as windows, fresh air intakes, etc.
7. Be sure that the minimum clearances to combustible materials and recommended service clearances are maintained. Units are designed for installation on with the minimum clearances shown in Table 3.2.
8. Do not install units in locations where gas ignition system is exposed to water spray, rain, or dripping water.
9. Mounting Height (measured from bottom of unit) at which unit heaters are installed is critical. Refer to mounting height information and heat throw data on page 17 of this manual. The maximum mounting height for any unit is that height above which the unit will not deliver heated air to the floor.

Figure 3.1
Typical Unit Locations

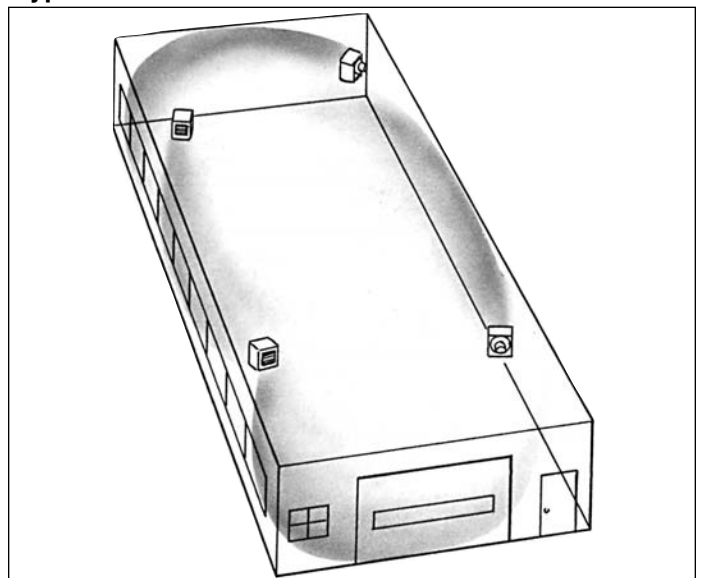

Table 3.2
Combustible material and Service Clearances
All Model Sizes

Top	Sides	Back	Front	Bottom	Flue
18"	18"	18"	Unobstructed	18"	18"

INSTALLATION

Combustion Air Requirements

For complete combustion, 14-1/2 lbs. of air is required for each pound of No. 2 fuel oil. Lack of combustion air can cause erratic burner operation, noisy combustion, fuel odors and soot deposits on heat exchanger walls resulting in lowered efficiency and high fuel consumption.

Units installed in tightly sealed buildings or confined spaces must be provided with two permanent openings, one near the top of the confined space and one near the bottom. Each opening should have a free area of not less than one square inch per 1,000 BTU per hour of the total input rating of all units in the enclosure with a minimum of 100 square inches for each opening, whichever is greater, freely communicating with interior areas having, in turn adequate infiltration from the outside.

For further details on supplying combustion air to a confined (tightly sealed) space or unconfined space, see the National Fuel Gas Code ANSI Z223.1 of CAN/CGA B149.1 or .2 Installation Code, latest edition.

Confined or Unconfined Spaces

The National Fuel Gas Code defines an "unconfined space" as a space whose volume is greater than 50 cubic feet per 1000 Btu/Hr input of the installed appliance(s). A confined space is 50 cubic feet or less per 1000 Btu/Hr input of the installed appliance(s).

Unit Suspension

CAUTION

1. Do not install units below 7 feet, measured from the bottom of the unit to the floor, unless properly guarded to provide protection from moving parts.
2. Do not install unit heater or vent pipe closer than 18 inches to combustible materials in any direction, except the front of the unit heater, which must be unobstructed.

1. Be sure the means of suspension is adequate to support the weight of the unit (see Table 17.1 for unit weights).
2. For proper operation, the unit must be installed in a level horizontal position.
3. Clearances to combustibles as previously specified must be strictly maintained.
4. It is recommended that adequate service access in access of 18 inches be provided for the burner and fan limit switch.
5. Do not install unit heater above the maximum mounting height shown in Table 17.2.

Four tapped holes (1/2" - 13) in the top of the unit are provided for unit heater suspension. Suspension can be made with threaded rods, pipes, or ceiling hanger brackets furnished by others. See Figure 17.1 for hanger hole locations and Figure 4.1 for suspension methods.

NOTE: A pipe hanger adapter kit, shown in figure 4.1 is available as an accessory from Modine, or can be self-fabricated. Kit consists of two drilled 3/4" I.P.S. pipe caps and two 1/2" - 13 x 1-3/4" capscrews to facilitate threaded-pipe suspension. Two kits are required for mounting each unit.

Figure 4.1
Suspension Methods

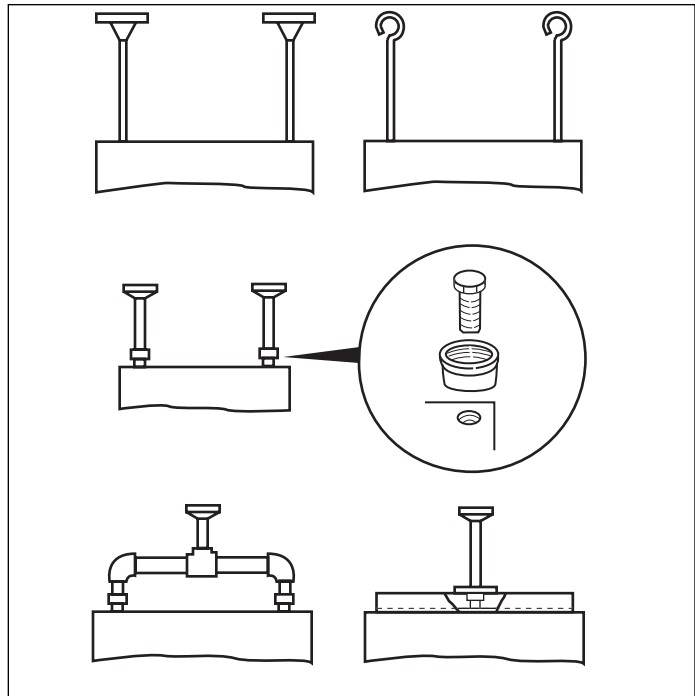

Venting

CAUTION

A barometric draft control must be installed on each unit heater, in the same space as the unit heater and as close to the unit as possible. See Figure 5.1.

1. To dispose of flue gasses, all oil-fired heaters must be vented per NFPA No. 31 "Installation of Oil Burning Equipment" and all local codes.
2. Do not install chimney connector closer than 18 inches to combustible materials in any direction. Where chimney connector passes through a wall or partition, a metal ventilated thimble not less than 12 inches larger in diameter than the connector must be used.
3. All Modine oil-fired heaters have an 8 inch vent connection. Never use a chimney connector smaller than 8 inches, except a 7 inch adapter may be used on Model POR100 to accommodate a 7 inch vent.
4. Install a barometric draft control the same size and on the vent pipe as close to the unit as possible. Installing a barometric draft control is essential for proper operation of the unit. Excessive over fire draft can cause unburned fuel to accumulate in the stack creating a potentially explosive condition. To install barometric draft control, refer to instructions furnished by draft control manufacturer. The air flow opening of the barometric draft control should face the front of the unit heater or away from air currents in the vicinity of the heater.

THE BAROMETRIC DRAFT CONTROL MUST BE ADJUSTED TO PROVIDE MINUS 0.02 INCHES W.C. (WATER COLUMN) OVERFIRE DRAFT AS MEASURED BETWEEN THE DRAFT CONTROL AND THE UNIT AND AS CLOSE TO THE UNIT AS POSSIBLE.

INSTALLATION

Venting - continued

5. If it is necessary to have an excessively high stack or if the stack is located such that it is susceptible to updraft conditions caused by wind, then oversized barometric dampers should be installed. In extremely windy locations, a Breidert type vent cap is recommended.
6. For the best venting, the chimney should be as close to the unit as possible. Keep flue pipes as straight as possible, avoiding sharp bends. Limit horizontal runs to 75% of vertical height or a maximum of 10 feet. Horizontal runs in excess of 10 feet require a draft booster. Chimney connector must be pitched at a minimum upward slope of 1/4 inch per foot.
7. Condensed flue products will cause rapid corrosion of vent pipes and heat exchanger. Where possible, avoid venting through unheated or unoccupied spaces. When necessary, insulate pipe from cold to maintain draft head and prevent condensation. Provide a drip leg with a clean-out cap at bottom of vertical pipe. See Figure 5.1.
8. The chimney must be high enough to provide a minus 0.02 inches W.C. (water column) overfire draft. The top of the chimney must be at least 3 feet above the highest point where it passes through the roof and at least 2 feet higher than any portion of a building within 10 feet of the chimney. See Figure 5.1.
9. When connecting vent to existing chimney, do not push vent pipe beyond internal surface of chimney.
10. If making more than one connection into the same chimney, the chimney connectors must enter at different levels and the area of the chimney must be equal to or greater than the combined areas of the individual connectors.

Figure 5.1 - Typical Venting Arrangement

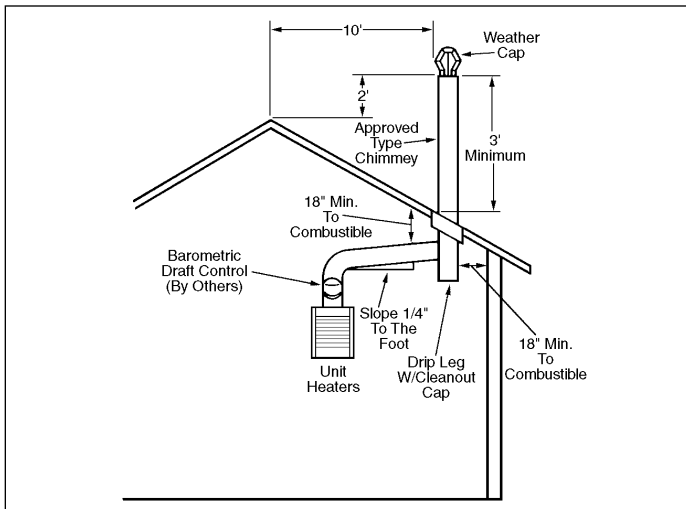

Figure 5.2 - Barometric Draft Control Above Unit



Wiring

WARNING

1. Disconnect power supply before making wiring connections to prevent electrical shock and equipment damage.
2. All appliances must be wired strictly in accordance with wiring diagram furnished with the appliance. Any wiring different from the wiring diagram could result in a hazard to persons and property.
3. Any original factory wiring that requires replacement must be replaced with wiring material having a temperature rating of at least 105°C.

General

All wiring must be done in accordance with the National Electric Code, latest edition, (NFPA No. 70). Canadian electrical code C22.1 applies in Canada.

Unit Heater Wiring

All internal wiring to the burner motor, fan motor and the fan and limit control has been completed at the factory. Provide 115-volt electric service from a fused disconnect switch to the octagon junction box on the rear of the unit heater. Wire must be insulated to 60°C and must be a minimum of 14-gauge (AWG) copper in at least 1/2 inch thin-wall or flexible metal conduit.

Thermostat Wiring

The proper wiring for a single thermostat for each unit heater is shown in Figure 6.1. The multiple unit wiring diagram shown in Figure 6.2 illustrates typical wiring and connections used with a centralized oil distribution system for multiple unit installations. This diagram is provided as a reference only, and is not intended to satisfy any particular local code requirements. System operation and compliance with local codes is the responsibility of the installer.

As shown, this system includes a relay for low voltage control of the booster pump, and the line voltage power supply to the booster pump motor. Figure 6.2 also shows the proper connections for multiple unit heaters, each controlled by a thermostat. In this arrangement, a 25V power source is connected to pressure switches on each unit. Upon demand for heat, a thermostat energizes the controls which start each burner. Meanwhile, separate pressure switches, on the fuel unit, sense an increase in oil pressure, and close their contacts to activate the booster pump switching relay, which in turn starts the booster pump. Optional high and low pressure controllers can supply line pressure. Location of a remote, low-voltage thermostat should be determined by the heating requirements and be mounted on an inside wall approximately 5 feet above the floor. It must not be located where it would be affected by direct heat from the unit or other sources or drafts from frequently opened doors or windows. See instructions packed with thermostat. The unit may also be controlled by a remote U.L. listed manual on-off switch.

INSTALLATION

Figure 6.1
Single Unit Wiring Diagram

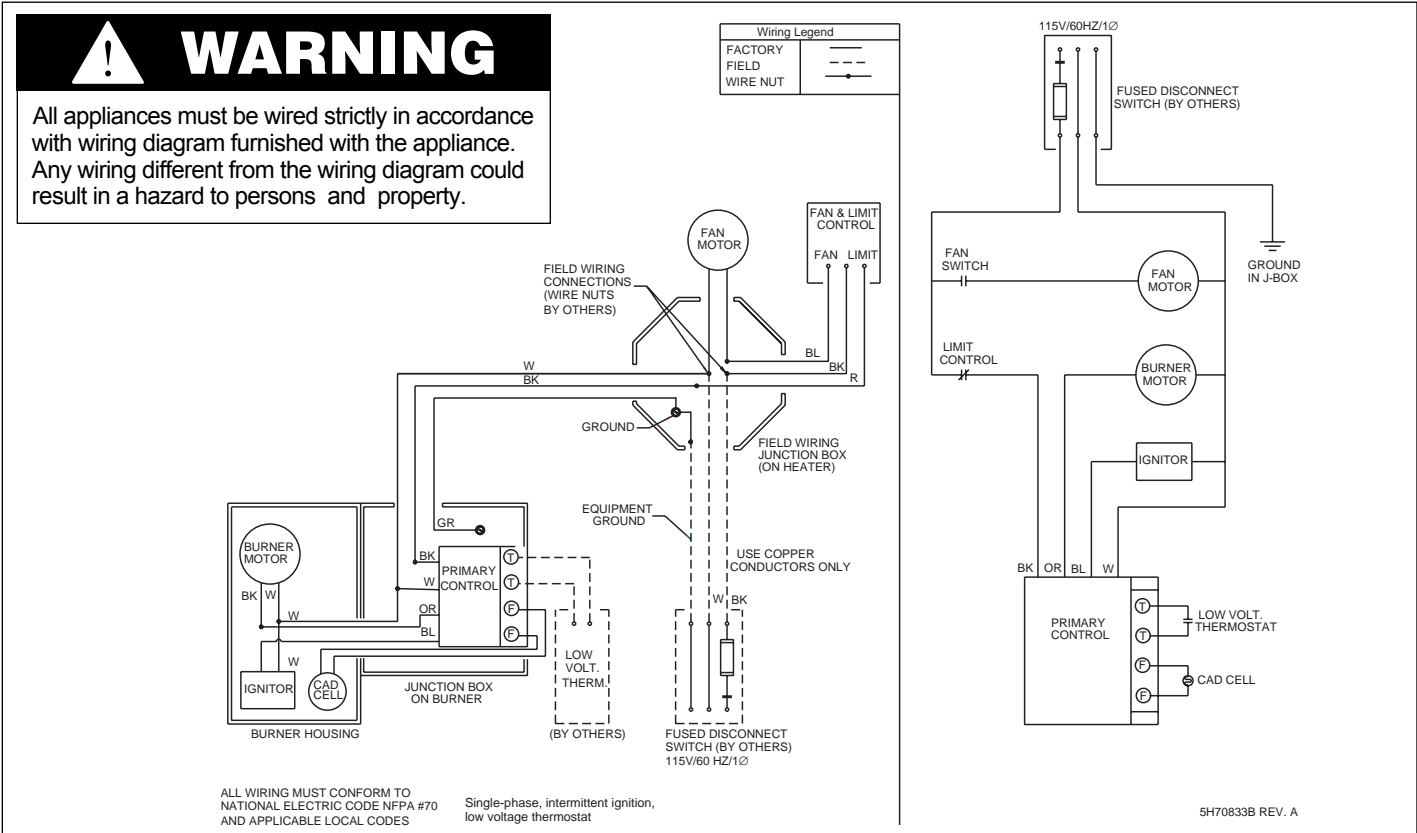
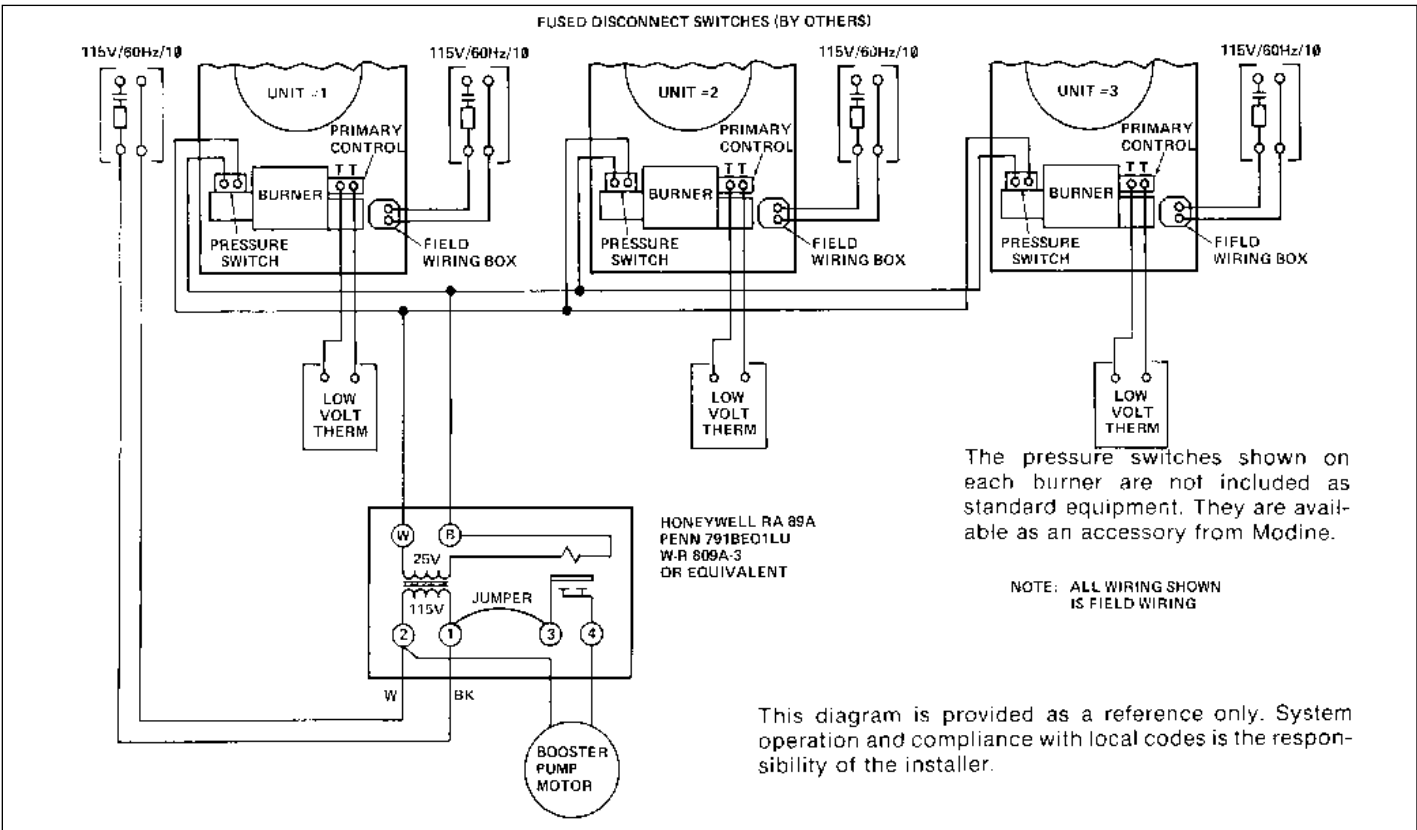

Figure 6.2
Typical Multiple Unit Installation and Booster Pump Wiring Diagram



INSTALLATION

Piping

CAUTION

Remove bypass plug from fuel unit when unit is connected to one pipe oil system. Failure to do so will permanently damage fuel unit and void warranty.

1. Recommend all piping be done in accordance with NFPA No. 31 "Installation of Oil Burning Equipment" and all local codes.
2. All piping shall be steel or brass pipe, with UL - listed fittings. Galvanized or wrought iron pipe is not recommended. 1/2 inch O.D. copper tubing with flared fittings is recommended for connecting the tank to the burner.
3. Protect piping from possible injury and fasten in place. Where practicable, it should be buried underground, or in a concrete floor, or placed in a metal-covered pipe trench. Do not cover piping until burner has been installed and operated so that any leaks may be corrected. Use non-hardening pipe thread compound resistant to oil for threaded connections.

IMPORTANT: ALL PIPE AND/OR TUBE FITTINGS ON FEED LINE TO BURNER MUST BE ABSOLUTELY AIR TIGHT! USE ONLY FLARED FITTINGS ON TUBING CONNECTIONS. DO NOT USE COMPRESSION FITTINGS.

Single-Unit Piping Two Pipe System

Modine oil-fired unit heaters are equipped with two-stage fuel units. They are recommended for use on two-pipe systems. (Supply and return lines connected to fuel unit) in high lift applications, up to 15 inches Hg (Mercury) inlet vacuum (20 foot vertical lift or equivalent) when directly connected to a supply tank. All unit heaters are shipped for use on two pipe systems. See Figure 8.1. If more than one unit is piped to the same tank, separate suction oil lines must be installed for each unit. A single common line, however, can be piped in series for fuel oil return.

One Pipe System

The fuel units supplied contain an internal by-pass and are shipped from the factory with the by-pass plug in place. **For one pipe installations (only supply line connected to fuel unit) remove this plug or permanent damage to fuel unit will occur.** One pipe systems are not recommended when vertical lift exceeds 10 feet.

Piping Selection

Table 7.1 can be used to approximate system piping requirements for two pipe systems. Determine the total lift in feet from the bottom of the supply tank to the fuel unit and subtract from 20 feet. This is the reserve available in feet of oil for piping losses. Determine the total equivalent length of piping by adding the total straight lengths to the equivalent length of straight pipe for each elbow and tee per Table 8.1. Locate the point of intersection of the total equivalent length of piping and the reserve piping loss in feet of oil on the graph. Always use the pipe size below this point on the graph to allow for unforeseen losses and ample reserve for filter losses.

**Table 7.1
Burner Fuel Unit Capacity**

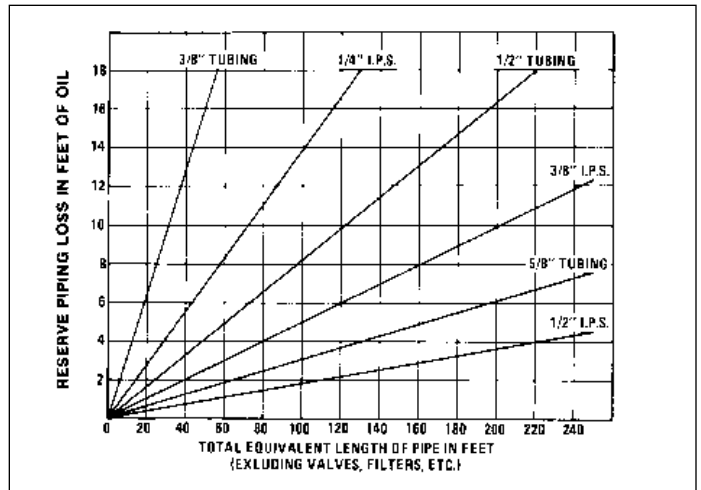

**Figure 7.2
Fuel Unit, Webster**

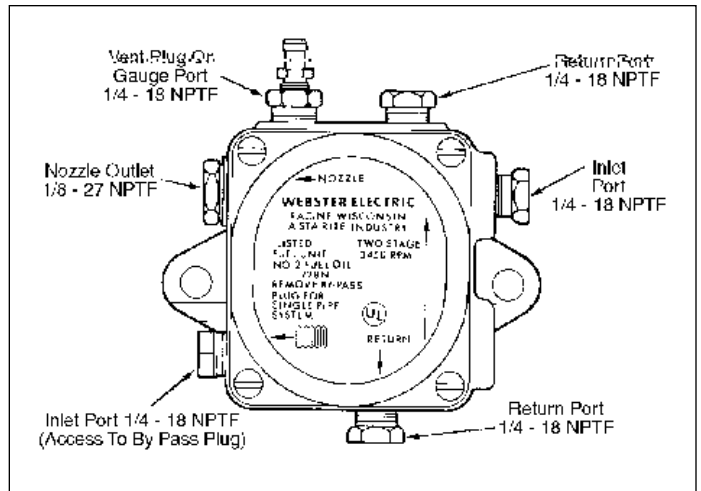

**Figure 7.3
Fuel Unit, Sundstrand**

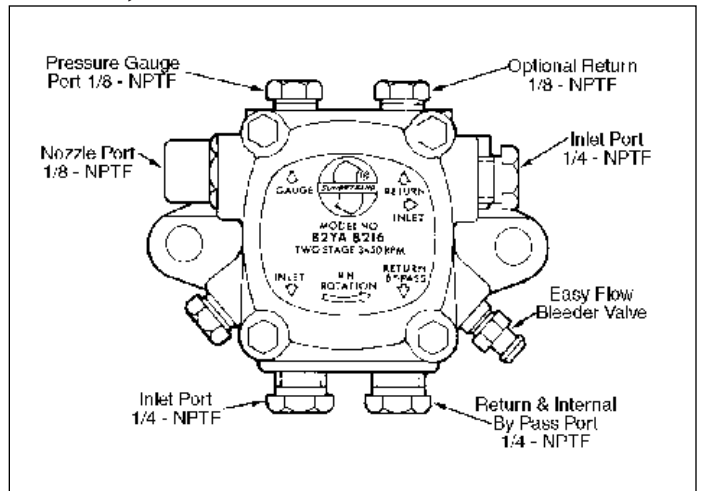

INSTALLATION

Figure 8.1
Two Pipe System

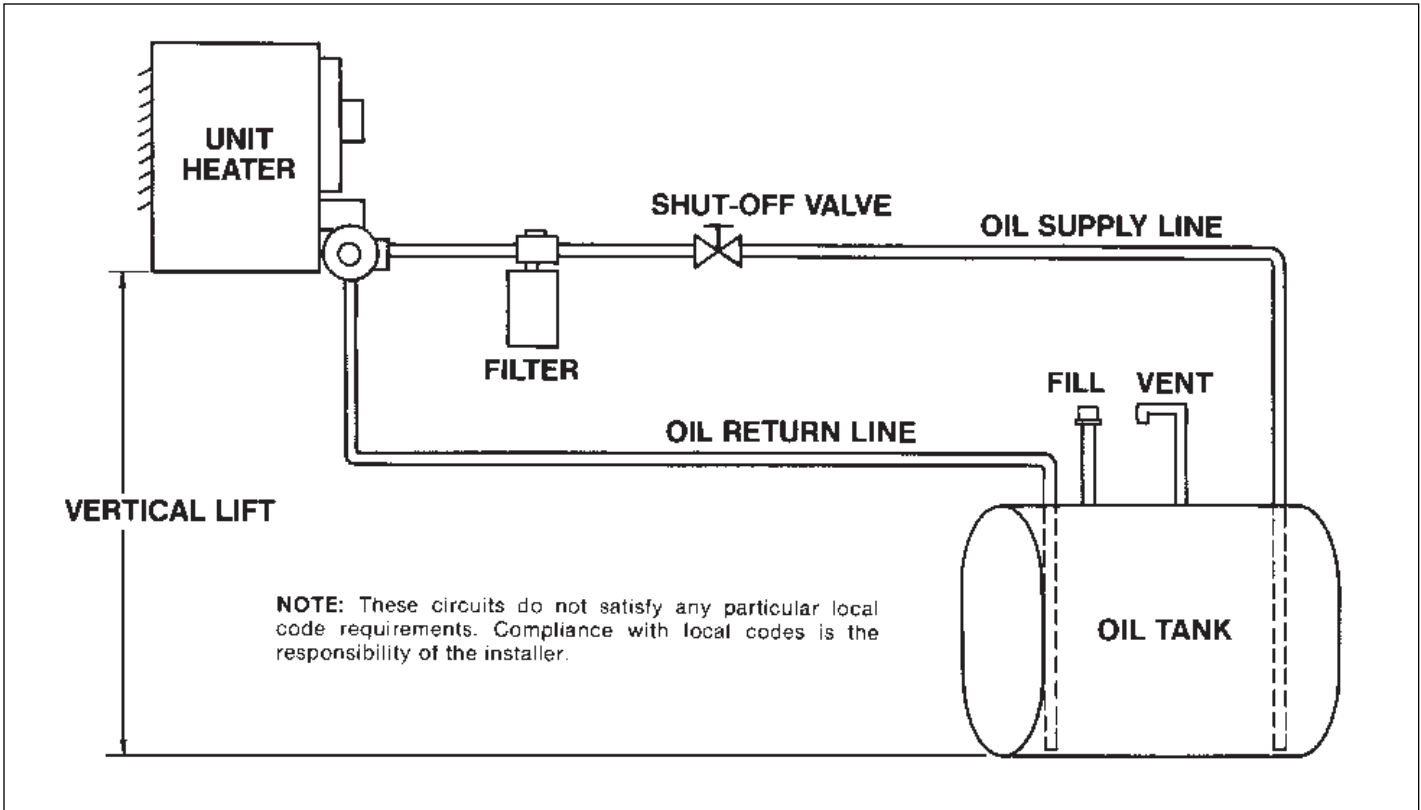

Table 8.1
Equivalent Length of Straight Pipe or Tubing (feet)

Fitting Type	3/8" O.D. Tube	1/2" O.D. Tube	1/2" I.P.S. Pipe	3/4" I.P.S. Pipe
90° ELL	1.4	1.4	1.7	2.1
45° ELL	0.5	0.5	0.8	1.0
TEE	0.5	0.5	0.7	1.1

Multiple Unit Supply

To save piping, oil tanks, and provide flexibility to extend pipe supply lines to multiple-unit installations, a centralized oil distribution system may be installed with a booster pump, oil safety valves, and vacuum breaker. Figures 9.1 and 9.2 illustrate typical loop and pressurized oil supply systems. In each of these systems the unit heater is installed as in a one-pipe system.

BE SURE TO REMOVE THE BYPASS PLUG FROM THE FUEL UNIT WHEN IT IS CONNECTED TO A ONE-PIPE OIL SYSTEM.

The loop system utilizes a vacuum breaker to assure an instant supply of oil to all units. NFPA requires that oil pressure at the fuel unit does not exceed 3 PSIG.

For multiple-unit systems, as shown in Figures 9.1 and 9.2, install a generous-capacity oil filter in the inlet line to booster pump suction line. Refer to Figure 6.2 for a typical wiring diagram for multiple unit installations.

Oil Tanks

To provide for a safe and continuous fuel supply, the tanks and piping to the unit heaters must be installed in accordance with state and local codes and must conform to applicable sections of NFPA No. 31, "Installation of Oil Burning Equipment." Keep oil storage tank filled, even during summer, to prevent condensation of water vapor. To prevent air locks, storage tank should not be filled while units are operating. If oil tank runs dry, it may be necessary to vent the air from lines and fuel unit when re-starting the burner.

Figure 8.2
Piping Connection to Fuel Unit Two-Pipe System

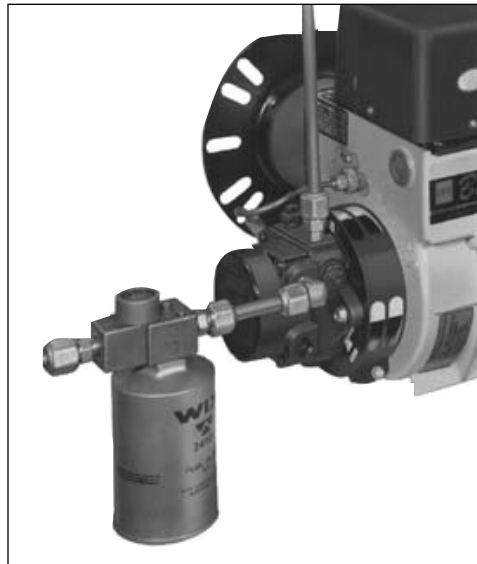

INSTALLATION

Figure 9.1
Typical Loop System for Multiple Units

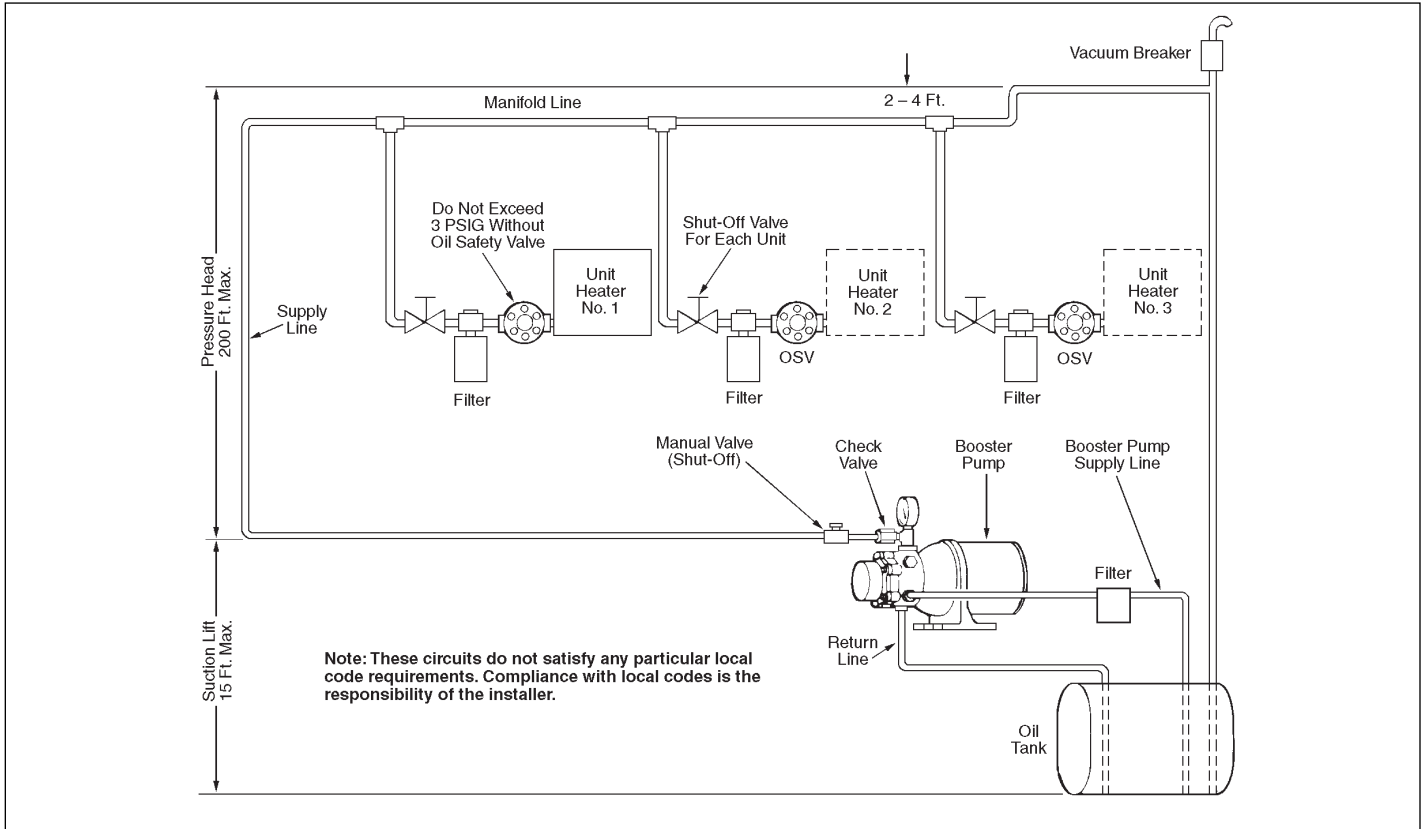
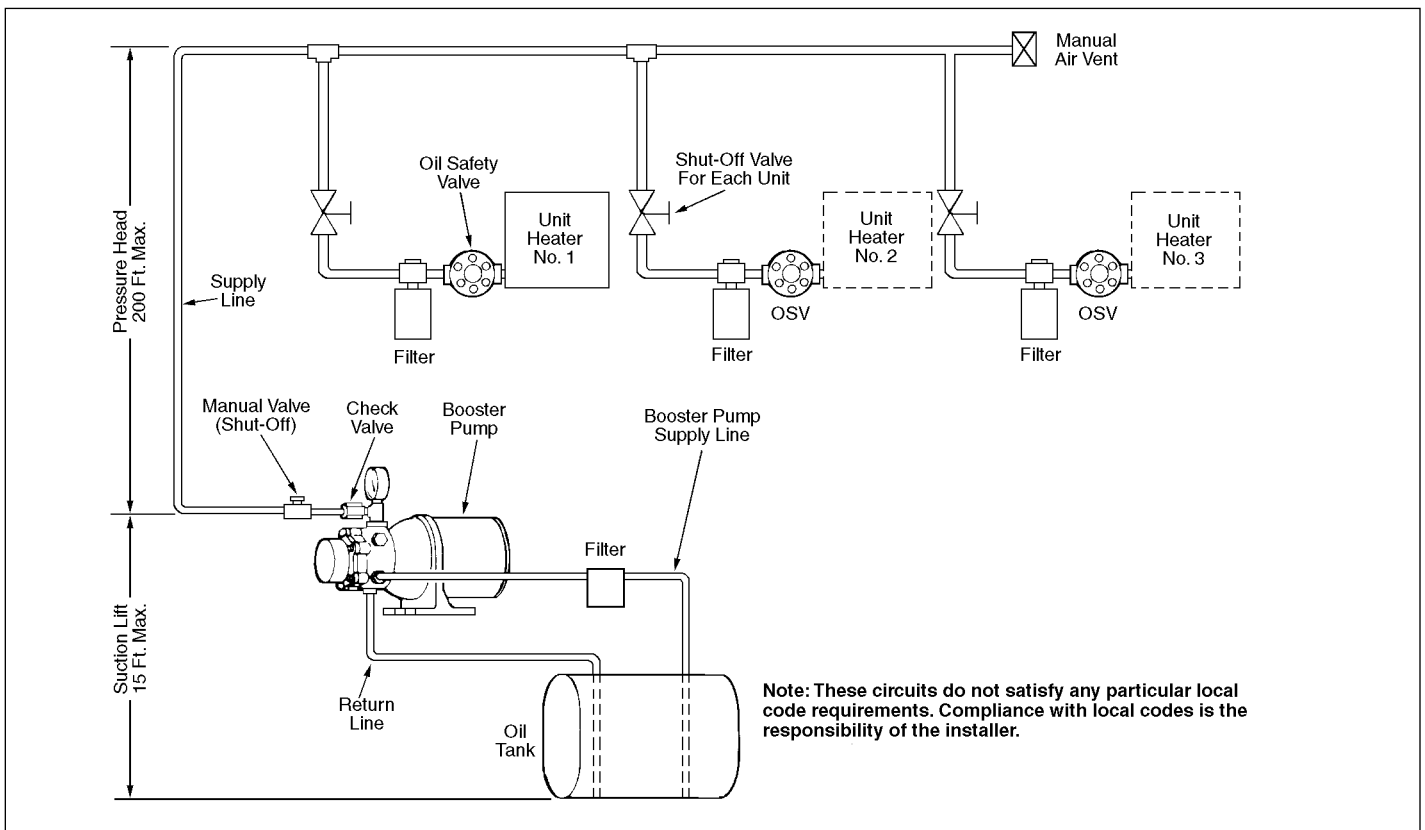

Figure 9.2
Typical Pressurized Supply System for Multiple Units



INSTALLATION

Accessories

Barometric Draft Control

Do not attach draft control to top or bottom of horizontal flue pipe or in a room separate from unit heater. The best location is as close to the unit heater as possible. Use a spirit level to make sure the draft control is plumb in all directions, regardless of whether the flue is horizontal, vertical or sloping. Refer to venting instructions in this manual for additional information on barometric draft controls. To install barometric draft control, consult instructions furnished by draft control manufacturer.

Figure 10.1
Barometric Draft Control



Oil Filter

On all installations, install an oil filter in the supply line immediately in front of the fuel unit. The fuel filter must always be installed lower than the fuel unit. Piping connections are 1/4" FPT. Refer to installation instruction furnished by filter manufacturer for more complete information.

Figure 10.2
Fuel Filter



Oil Safety Valve

The OSV can be installed in any position. Preferred position is cover up. The "IN" port is connected to the supply line, the "OUT" port to the burner line. Do not install backwards.

CAUTION

Do not mount the OSV more than three feet above the burner inlet or above the lowest point in fuel line pipings between burner and OSV. In-line mounting is recommended.

The OSV is opened by a slight vacuum appearing at the outlet of the OSV, generated by the burner fuel unit. Failure to observe the above caution may result in siphoning action in the event of failure of the fuel line between burner and OSV.

Refer to instructions furnished by valve manufacturer for complete installation instructions. Piping connections for 3/8 inch FPT.

Figure 10.4
Oil Safety Valve



Pressure Switch

The pressure switch is piped to the pressure gauge port on the burner fuel unit. Its 25V contacts close, activating a booster pump relay, when the burner starts. Consult switch manufacturer's instructions. Connection is 1/8 inch MPT.

Figure 10.5
Pressure Switch



OPERATION

Figure 11.1
Cutaway Through Oil-Fired Unit Heater

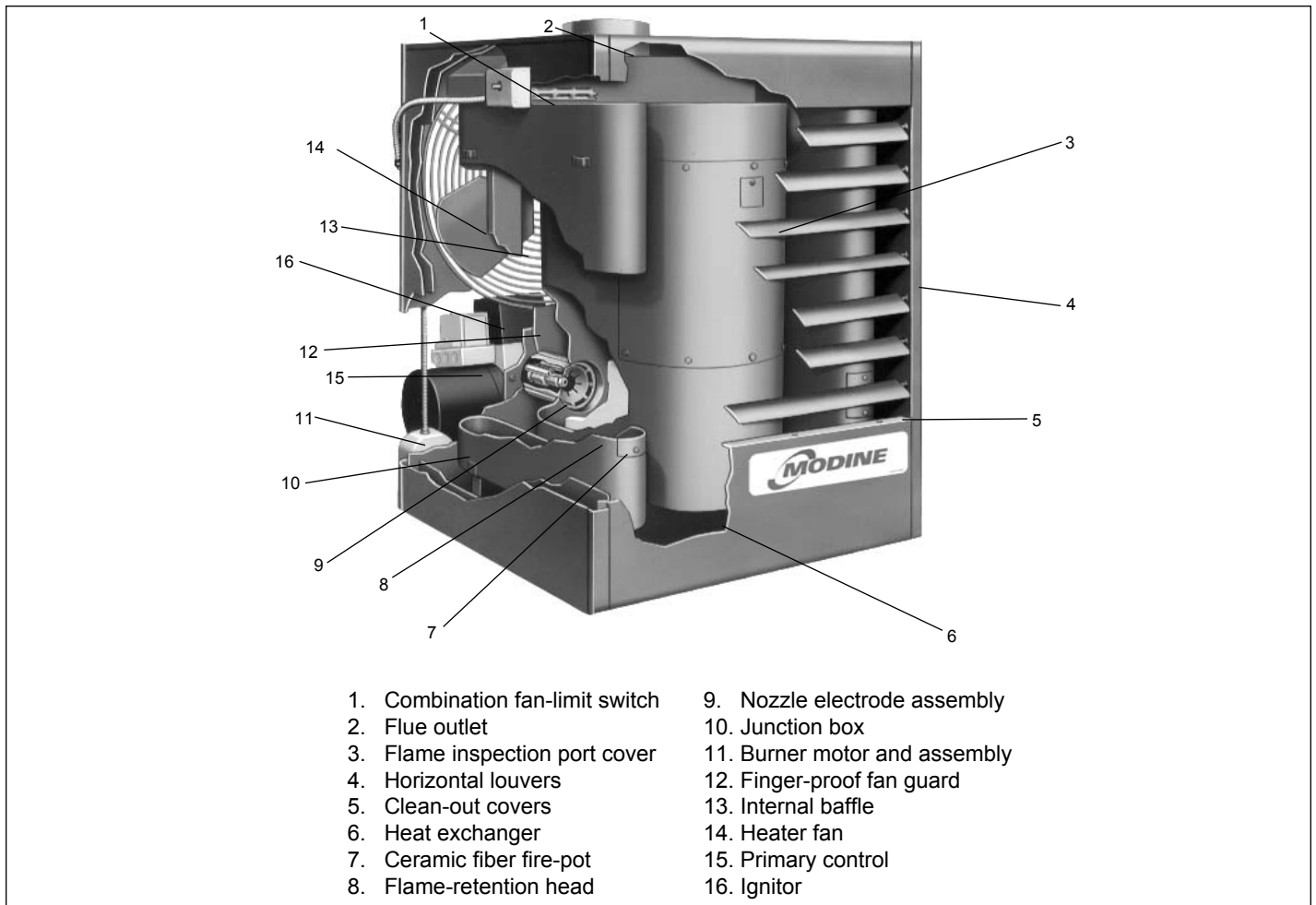

Operating Sequence

CAUTION

Start-up and adjustment procedures should be performed by a qualified oil serviceman.

The operation of Modine oil-fired unit heaters is governed by a primary control which operates the burner, and a fan and limit switch which controls the circulating air fan dependent on the heat exchanger temperature.

The primary control is energized when the thermostat “calls” for heat. It starts the burner motor which turns the combustion air blower and fuel unit. The fuel unit is a 2-stage type that draws oil from the supply tank and delivers it at high pressure to the burner nozzle.

Combustion will be established and the heat exchanger will begin to warm-up. When the fan and limit switch detects the proper temperature, it will turn on the circulating air fan. The time it takes before the circulating air fan turns on after the burner is started is a function of the temperature setting on the fan and limit switch.

When the thermostat is satisfied, the primary control will shut off the burner. The circulating air fan will shut off when the fan and limit switch detects a sufficiently low temperature. The fan and limit switch also has a manual switch which allows constant “fan on” operations.

Safety Devices

The primary control is a constant ignition device that allows the electrodes to spark continuously as the burner runs. It uses the cad cell to detect the presence of a flame. Upon start-up, if no flame is detected, the primary control will permit the burner to run for a maximum of 15 seconds before “lockout”. It must be manually reset before the unit can be started.

CAUTION

Do not reset primary control if heat exchanger is hot. If unit fails to operate properly after resetting twice, consult qualified oil serviceman.

OPERATION

During the normal operation, if the flame is lost for about 15 seconds, the primary control will again “lockout” and must be manually reset.

The fan and limit switch performs the dual function of operating the circulating air fan and turning the burner off if an overheat condition occurs. Such a condition would exist if insufficient circulating air is driven across the heat exchanger or if the unit is over-fired.

The motor for the circulating air fan has internal thermal overload protection. If for any reason, the motor overheats, the thermal protector will shut it off. The motor will re-start automatically when it has cooled.

Prior to Operation

Although this unit has been inspected and fire-tested at the factory, the following procedures should be performed to assure proper on-site operation:

1. Check fan clearance. 1/4 inch is allowed between fan blade tip and venturi.
2. Check all electrical connections to be sure they are secure, and in accordance with the wiring diagram.
3. Check firmness of unit suspension. Tighten all fasteners, if necessary.
4. Inspect vent pipe for rigidity of mounting. Gate on barometric draft control should operate freely.
5. Trace oil lines for closed shut-off valves or filter head valves. Open valves as required.
6. Inspect oil supply in storage tank to assure there is sufficient fuel.
7. Check piping components (filters, OSVs, etc.) to make sure they are installed in the proper relationship to the direction of oil flow.
8. Check to assure good electrical contact between transformer terminals and electrode buss bars.

Figure 12.1
Burner Assembly with Webster Fuel Unit

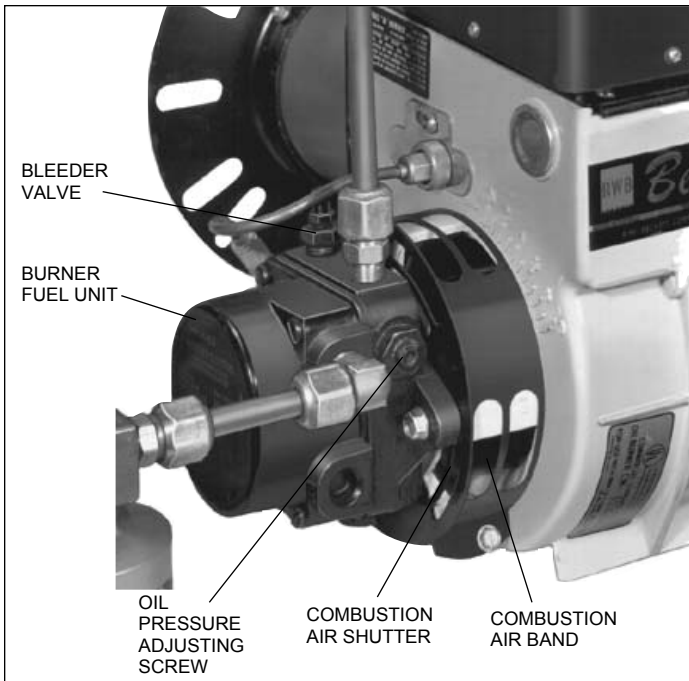
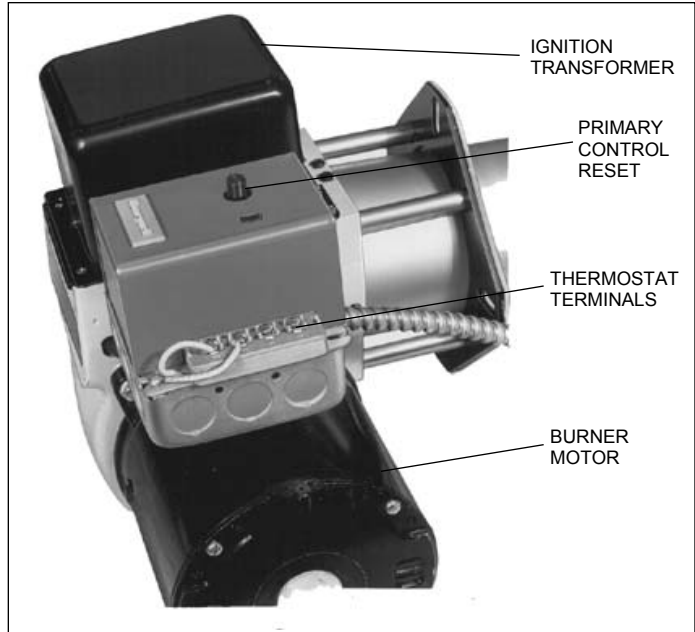

Figure 12.2
Burner Assembly



Initial Start-Up

1. Adjust room thermostat above room temperatures.
2. Open shut-off valves at tank and in oil supply line to the burner.
3. Turn on power to the unit. If burner does not start immediately, push reset buttons on burner motor and primary control.
4. For units installed on a single pipe system, vent air from fuel unit and oil supply lines immediately after the burner motor starts. Vent air by opening bleeder valve on fuel unit until oil appears clear (no foam), then close tightly. Ignition should occur as soon as bleeder valve is closed.

If the air cannot be vented and ignition established within 15 seconds, the primary control will “lockout” and shut off the burner. If this happens, wait several minutes to make sure the heat exchanger is cool then push red reset button on primary control. Repeat venting procedure until ignition has been established.

For units installed on a two pipe system, venting of air from oil lines is not necessary. However, ignition will not occur until the air has been purged from the fuel unit and nozzle line. This may take longer than 15 seconds and cause the primary control to “lockout”. If this happens, wait several minutes to make sure the heat exchanger is cool, then push red reset button on primary control. Repeat venting procedure until ignition has been established.

5. After ignition has been established, adjust the air bands located on the left side of the burner to produce a #1 smoke reading and allow the unit to run for approximately 10 minutes before making further adjustments. Then, adjust the barometric draft control to produce a minus 0.02 inches W.C. overfire draft. The draft reading must be taken in the flue pipe between the barometric draft control and the unit and as close to the unit as possible.

OPERATION

- Shut unit off and connect a pressure gauge to the pressure gauge port on the fuel unit. When the unit is turned on, the pressure should be 100 ± 2 PSI. If pressure adjustment is necessary, remove cover plug of pressure-regulating port and adjust pressure with screwdriver or Allen wrench. See Figure 7.2, 7.3, and 8.1.
- After the oil pressure is set, readjust the air bands to produce just a trace of smoke which is slightly less than #1. A carbon dioxide (CO_2) check at this smoke level should read 10% to 11%.
- The fan and limit switch is factory set at a high limit temperature of 210°F . Do not change this setting. It is also factory set to turn on the fan at 120°F and turn it off at 90°F . These settings may be changed by following the control manufacturer's instructions packed in the literature envelope attached to the unit. Since the fan and limit control is operated by a thermal switch, not the thermostat, residual heat in the heat exchanger can cycle the fan on after the thermostat has been satisfied.
- Adjust the air deflector blades for desired heat distribution. All horizontal blades should be kept open a minimum of 30° as measured from vertical.
- Run the unit through several cycles by raising and lowering the thermostat setting to assure proper sequence of operation.

Figure 13.1
Electrode Gap, Beckett Burner

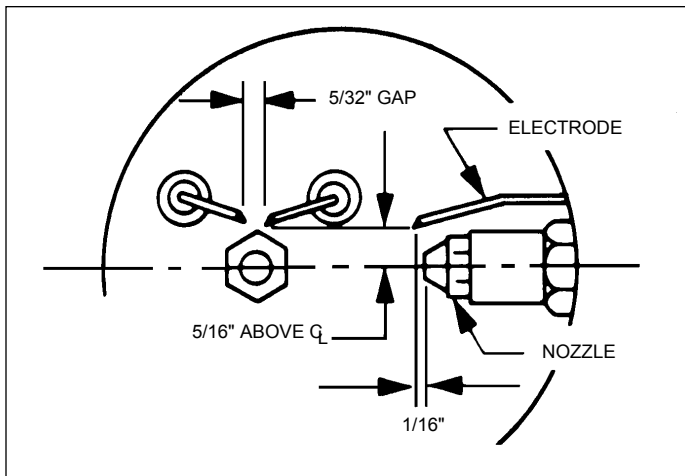
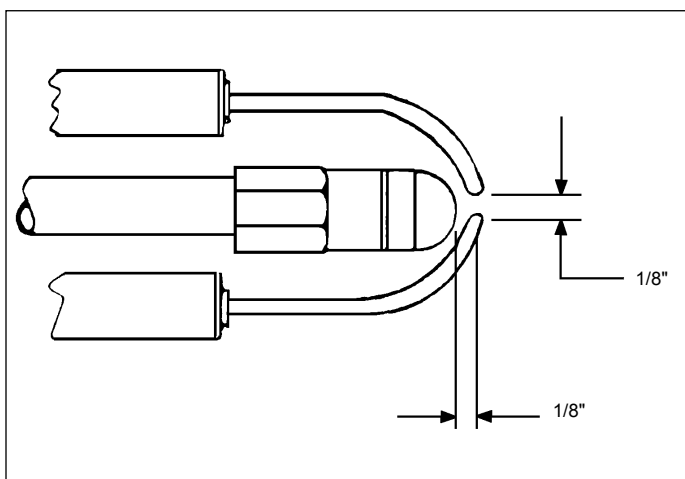

Figure 13.2
Electrode Gap, Wayne Burner



Service Instructions

CAUTION

Service procedures should only be performed by a qualified oil serviceman.

Routine Unit Maintenance

Under average conditions, it is recommended that unit heaters be serviced at least once a year and checked out prior to the heating season. In excessively dirty atmospheres, service should be performed more often.

- Disconnect power supply to the unit before performing any of following maintenance of inspection procedures.
- Tighten fan guard and motor bracket. Check fan for proper clearance, free rotation, and firm connection to motor shaft. Clean fan blade with detergent or compressed air.
- Fan motor is permanently lubricated for normal operation. Under severe conditions, lubricate with non-detergent SAE 20 motor oil.
- Routine cleaning of the unit casing and louvers is recommended to remove dirt, grease, or corrosive substances that may damage the finish. Rusted or corroded spots on the louvers or casing should be sanded and repainted. To remove, push louvers against retaining coil spring and pull out at opposite tapered end.
- With louvers removed inspect inside of heat exchanger with a flash light through the flame inspection port. Check for soot deposits, damaged fire pot, heat exchanger or burner head.
- If there is a heavy soot-coating inside heat exchanger, it should be drawn out with a vacuum cleaner after removing the front access panel. Care must be taken not to damage the fire pot during the cleaning operation.
- Replace fuel oil filter elements at unit heater and at booster pump to prevent contamination of the fuel unit and atomizing nozzle.
- Check entire electrical system before every heating season.
- Make sure gate on barometric draft control swings freely.

Oil Burner Service

The electric motor-driven burner assembly supplied with the Modine oil-fired unit heaters lifts, pressures and atomizes a continuous charge of fuel oil with a forced draft of combustion air into the heat exchanger fire pot where it is ignited by sparking electrodes. Burner components that will require inspection and service include the burner motor, blower wheel primary control, nozzle, nozzle, electrodes, and the fuel unit. Either of two makes of burners are used with Modine unit heaters, namely Beckett or Wayne, these burners utilize either a Honeywell, or White-Rodgers primary control and cad cell and either a Webster or a Suntec fuel unit. Refer to manufacturer's instructions packed with each unit.

SERVICE INSTRUCTIONS

To Service Burner Assembly

1. Disconnect electric power to unit.
2. Remove fasteners on hinged ignitor on top of the unit and swing back giving access to the inside of the burner housing, the nozzle, cad cell, and blower wheel.
3. Clean blower wheel and combustion air openings with vacuum cleaner or air hose, if required.
4. The nozzle should be replaced every year, more often if it is dirty or carbonized. To replace nozzle disconnect external oil line at the burner housing, then remove the drawer assembly (nozzle line and electrode assembly) locknut from the fitting. Lift drawer assembly up and out of the air blast tube. Do not disturb drawer assembly adjustment setting. Replace nozzle with type as specified below:

POR 100	0.85 GPH	70° SOLID CONE
POR 145	1.25 GPH	70° SOLID CONE
POR 185	1.65 GPH	70° SOLID CONE

CAUTION

Never use a nozzle size or type other than specified in Service Instructions.

Use extreme care in handling nozzles to avoid scratches or dirt that could cause leaks or affect the oil spray pattern.

5. Check electrodes. The proper setting is essential for reliable ignition of the oil. Set the electrodes as illustrated in Figures 13.1 or 13.2.
6. Check the cad cell for an accumulation of dirt or soot. Clean if necessary with a soft cloth.
7. Lubricate burner motor with a few drops of non-detergent oil at both motor oil holes twice each year on units that are not permanently lubricated with sealed bearings.

Burner Adjustments

CAUTION

1. Do not attempt to start the burner when excess oil has accumulated in the combustion chamber, when the heat exchanger is full of oil vapor or very hot.
2. Burner adjustments should only be performed by qualified oil serviceman.

It is recommended that a combustion check be made on the burner each year or whenever replacing a nozzle. This will help assure efficient combustion of the oil and avoid sooting the heat exchanger.

The flame can be viewed through the inspection port located on the front of the heat exchanger. DO NOT ATTEMPT TO VIEW THE FLAME WHILE STARTING THE BURNER, SINCE PULSATIONS WHICH SOMETIMES OCCUR UPON START-UP CAN DISCHARGE HOT GASES THROUGH THE INSPECTION PORT.

Figure 14.1
Draft Gauge with Probe



Figure 14.2
Smoke Tester and Scale



Figure 14.3
CO₂ Analyzer and Calculator



SERVICE INSTRUCTIONS

The best adjusted flame pattern will be a clean, yellow, solid cone which is well established on the burner head and terminates into short licks of flame within the ceramic fiber fire pot.

An accurate combustion check can only be made with the proper instrumentation as described below.

- A. Install a pressure gauge on the pressure gauge port of the fuel unit. Start burner and adjust oil pressure to 100 psi. See Item 6 - Initial Start-Up.
- B. Make two holes about 1/4 inch in diameter in the flue pipe about 6 inches above the flue connection but below barometric draft control. Two openings permit taking the stack temperature in one, while the second opening is used to conduct draft test, and carbon dioxide (CO₂) test. Close openings with sheet metal screws after tests have been completed.
- C. Insert stem of stack thermometer in one opening while performing other tests.
- D. Allow burner to operate approximately 5 minutes before taking any readings. To measure draft, place draft gauge on any level surface adjacent to the unit heater and adjust it to zero. Draft gauge should read minus 0.02 inches W.C. minimum. Draft can be changed by adjusting the weight on the barometric draft control. Improper draft can cause erratic and incomplete combustion which will result in noisy operation, soot deposits, excessive smoke and fuel oil odors.
- E. The smoke tester measures smoke content of flue gas and is prepared by inserting a strip of clean filter paper in the slot provided. Insert probe into flue and pump smoke tester ten strokes to draw a sample of flue gas through the filter paper. Filter paper should be removed and compared against the standard Bacharach smoke scale which has ten graded color spots from white (0 smoke) to the darkest shade of gray. To adjust the combustion air, loosen the locknut for the combustion air bands on the side of the burner and rotate the bands slightly until a #0 to #1 smoke reading is achieved. Increasing the air opening will lighten the smoke spot and decreasing the air openings will darken it. Tighten locknut and recheck reading.
- F. Test the flue gas for carbon dioxide (CO₂) content. Zero the CO₂ analyzer and insert probe into flue pipe and draw sample of the flue gas into analyzer. The concentration of CO₂ should be 10% to 11% at zero smoke.
- G. Conclude testing by reading stack temperature and subtract room temperature to get the net stack temperature. Using this figure and the CO₂ reading, use the slide calculator provided with the CO₂ analyzer to compute steady-state efficiency. Efficiencies of 80% should be attainable.

Primary Control Service

The primary control (see Figure 12.2) is not intended to be serviced in the field. Replace defective controls. It senses ignition failure and flame failure and can be checked by a relatively simple procedure. Start the unit.

- a. Simulate flame failure by removing one cad cell lead from the F terminal of primary control with burner on. Fifteen seconds after flame extinguishes, primary control will lock out and stop burner motor and ignition spark. Attach the cad cell lead to the F terminal. Reset safety switch on top of primary control after test.

CAUTION

Do not reset primary control if heat exchanger is warm. Wait till cool.

If operation is not as described and wiring is in accordance with diagram on page 6, refer to cad cell service before replacing primary control.

Cad Cell Service

Under normal operating conditions the cad cell does not require cleaning. Small accumulations on the surface of the cell will not affect its operation. However, if a badly adjusted burner has caused heavy accumulation of soot, the surface should be wiped carefully to remove all opaque substances and restore full view of the oil flame.

If cad cell should ever be damaged, the cell may be removed by simply unplugging it from the socket assembly. Avoid disturbing the positioning of the socket assembly. Replace the damaged cell.

Figure 15.1
Cad Cell



Fuel Unit Service

A two stage, 3450 RPM fuel unit is supplied on all Modine oil unit heaters. Two stage fuel units are intended for high lift applications, up to 15 inches Hg. (Mercury) of inlet vacuum or the equivalent of 20 feet of vertical lift. It is recommended that they be used with a two pipe oil supply system and they are shipped with the bypass plug installed for such applications.

Either a Webster or Suntec fuel unit may be provided on Model POR oil unit heater. See Figures 7.2, 7.3, and 12.1. The Webster fuel unit has a rotary, self-cleaning filter that requires no periodic inspection.

SERVICE INSTRUCTIONS

The suntec fuel unit utilizes an internal strainer to trap foreign material. Periodically, remove the fuel unit cover and clean the strainer with a brush and clean fuel oil. Generally, service problems do not occur with a fuel unit. A thorough check should be made before replacing any fuel unit.

- A. Install a vacuum gauge on an unused inlet port, when the unit is turned on, the gauge should read approximately 1 inch of vacuum for each foot of vertical lift. Gravity fed fuel units should read zero vacuum. If reading is higher than expected, check for a closed tank or supply valve, kinked tubing, plugged filter or strainer, frozen oil line, undersized oil line or excessive oil lift, if gauge reads below expected vacuum, look for air leaks in the oil hinges, valves, fittings or fuel unit.
- B. Install a pressure gauge on the gauge port of the fuel unit. Pressure should read 100 ± 2 PSI. If adjustment is necessary, refer to Item 6 - Initial Start-Up. If needle on gauge bounces, see service diagnosis for remedy.
- C. To check the fuel unit cut-off pressure, install a pressure gauge in the nozzle port. Operate the unit for approximately one minute, then shut the unit off. The pressure should read 100 PSI while the unit is running and should not drop to less than 80 PSI and hold there after the burner is shut off. If the pressure drops to zero, the fuel unit should be replaced.

Fire Pot Service

The ceramic-fiber fire pot will seldom, if ever, require replacement unless it is accidentally damaged during a heat exchanger cleaning operation. To replace, take off the front access panel and remove all fire pot pieces. Carefully insert new fire pot with the enclosed corbeled end to be opposite the burner nozzle. (Open end of fire pot must be toward nozzle.)

CAUTION

To prevent unusual thermal stress and eventual harm to the heat exchanger, do not operate unit heater without fire pot or with a damaged fire pot that does not enclose the flame.

Figure 16.1
Ceramic-Fiber Fire Pot

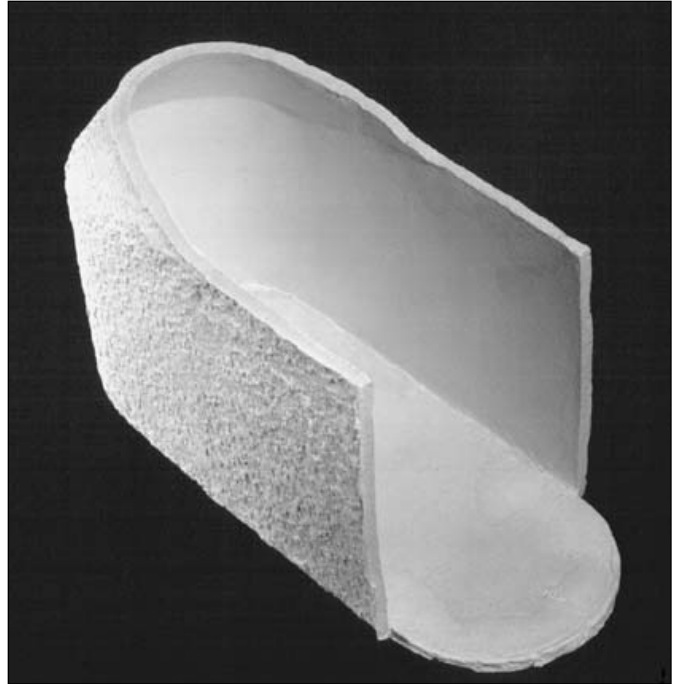

Replacement Parts

All replacement parts and controls are proprietary in that they have all been designed, tested, and approved for the particular application to insure both physical and electrical fit and performance. Any substitution of parts or controls not approved by Modine will be at customer's risk.

NOTE: Modine Manufacturing Company reserves the right to substitute parts of advanced design and to change specifications or prices without advance notice or without incurring obligations.

Replacement parts can be obtained by submitting the model number, power code, control code, and serial number shown on the rating plate attached to the unit, along with a description of the part, to the Service Department, Modine Manufacturing Company, West Kingston, RI 02892.

DIMENSIONAL/PERFORMANCE DATA

Figure 17.1
Oil-Fired Unit Heater Dimensions

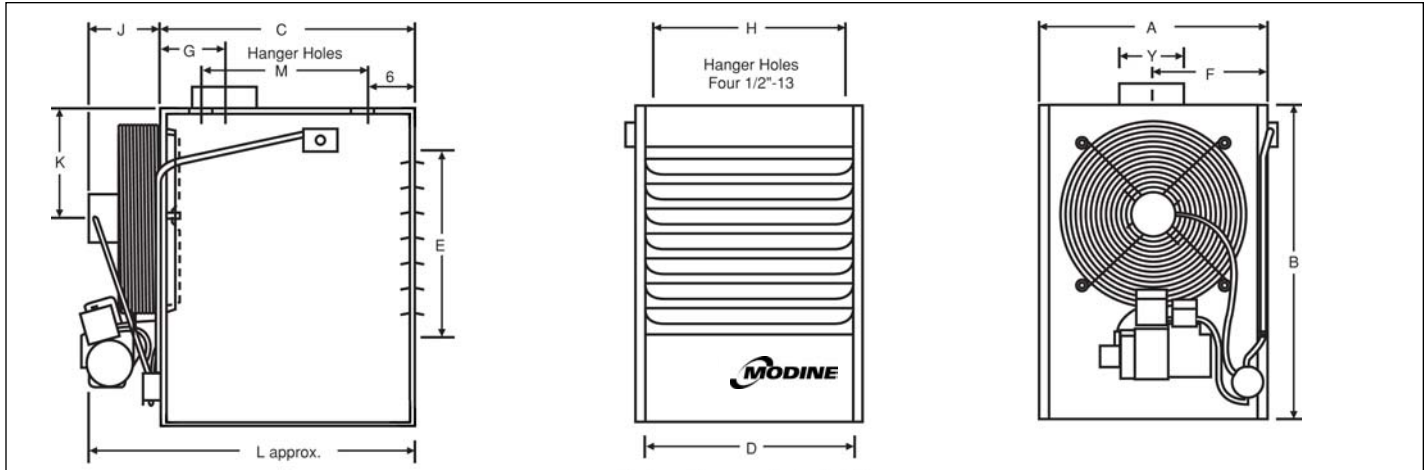

Minimum Clearances - Inches

Top - 18" Front unobstructed
Sides 18" Bottom 18"
Back 18" Flue 18"

Table 17.1
Outline Dimensions (inches)

Model	A	B	C	D	E	F	G	H	J	K	L	M	Y	Approx. Shipping Wt. Lbs.
POR 100	27-1/2	35-1/4	28-1/8	25	23-7/8	13-3/4	8-5/8	23-7/8	8	12	38-1/8	16	8	324
POR 145	27-1/2	35-1/4	28-1/8	25	23-7/8	13-3/4	8-5/8	23-7/8	9-1/2	12	38-1/8	16	8	333
POR 185	28-5/8	40-1/4	32-3/4	26-1/8	23-7/8	14-3/8	8-5/8	25	10	13-3/4	42-3/4	20-3/4	8	398

Table 17.2
Performance Data

Model	Input BTU/HR	Input GPH	Output BTU/HR	CFM @ 70°F	Delivery FPM	Temp Rise °F	Max. Mtg. Ht. Ft*	Heat Throw Ft.
POR 100	119,000	.85	100,000	1890	460	49	12	39
POR 145	175,000	1.25	145,000	2400	580	56	13.5	50
POR 185	231,000	1.65	185,000	3200	740	54	12	51

*Deflector blades pitch 45° toward the floor. (Heated air). Mounting heights measured from floor to bottom of unit. The maximum mounting height is that height above which the unit will not deliver heated air to the floor.

Table 17.3
Fan Motor Specifications

Model	HP	Voltage	Hz	Phase	Fan Motor* Amps.	RPM	Type	Fan Dia.
POR 100	1/5	115	60	1	2.1	1100	PSC	18"
POR 145	1/3	115	60	1	5.4	1100	PSC	18"
POR 185	1/3	115	60	1	5.4	1100	PSC	22"

*Total amps equals fan motor amps plus burner and ignition transformer load of 5.8 amps.

SERVICE & TROUBLESHOOTING

⚠ WARNING

When servicing or repairing this equipment, use only factory-approved service replacement parts. A complete replacement parts list may be obtained by contacting Modine Manufacturing Company. Refer to the rating plate on the appliance for complete appliance model number, serial number, and company address. Any substitution of parts or controls not approved by the factory will be at the owner's risk.

⚠ CAUTION

Do not attempt to reuse any mechanical or electrical controllers which have been wet. Replace defective controller.

IMPORTANT

To check most of the Possible Remedies in the troubleshooting guide listed in Table 18.1, refer to the applicable sections of the manual.

Table 18.1 - Troubleshooting

	Remedy
Problem A. Unit does not operate.	
<ol style="list-style-type: none"> No oil. Electric circuit in open position. Blown fuses. Burner motor runs but no spark. Defective or incorrect wiring. Defective thermostat or switch. Primary control locked out on safety. Defective cad cell. Burner or fan motor out on overload. 	<ol style="list-style-type: none"> Fill oil tank or open supply valve or check filter. <ol style="list-style-type: none"> Turn on switch or thermostat. Move thermostat to higher setting. Replace fuse or reset disconnect switch. Replace fuses. Check electrode spacing or replace ignitor. Check wiring and connections. Refer to diagram. Check continuity with volt-ohmmeter. Replace defective part if necessary. Push reset button on primary control only if heat exchanger is cool. Try this only twice. See control service instructions. Replace cad cell if necessary. Check continuity. Check voltage wiring and motor. Reset overload button on burner motor. Fan motor automatically reset.
Problem B. Unit starts and shuts off.	
<ol style="list-style-type: none"> Clogged nozzle. Air leaks in suction line. Faulty ignition. High draft, too much air. Improper oil pressure. 	<ol style="list-style-type: none"> Replace nozzle. Tighten all fittings. <ol style="list-style-type: none"> Reset electrodes in burner assembly. Check insulators. Check wiring at primary control. Replace ignitor, if required. Check draft regulator adjustment. Adjust combustion air openings on burner. Adjust fuel pump with pressure and vacuum gauges.
Problem C. Fan operates but burner does not operate.	
<ol style="list-style-type: none"> Manual fan switch is on. See burner service diagnosis. See fuel pump service diagnosis. 	<ol style="list-style-type: none"> Turn off manual fan switch. See burner service diagnosis. See fuel pump service diagnosis.
Problem D. Burner operates but fan does not operate.	
<ol style="list-style-type: none"> Fan motor failure. Loose fan. Defective fan switch in fan limit control. Defective or incorrect wiring. 	<ol style="list-style-type: none"> <ol style="list-style-type: none"> Check for loose electrical connections. Check wiring with diagram on rear of heater. Repair or replace burned out or defective motor. Voltage too high or too low. Check voltage with voltmeter. Tighten fan set screw. Replace entire control. Check all wiring and connections. See diagram on rear casing panel.
Problem E. Insufficient heat.	
<ol style="list-style-type: none"> Too few units for heat loss. Unit mounted too high. Fan operates backwards. 	<ol style="list-style-type: none"> Add more units or use larger size units. Lower units. Replace motor.
Problem F. Loud noise during starting.	
<ol style="list-style-type: none"> Water in oil. Delayed ignition. 	<ol style="list-style-type: none"> Bleed line at fuel unit. Replace supply if necessary <ol style="list-style-type: none"> Reset electrode gaps. Nozzle worn or dirty. Replace nozzle. Check voltage drop when burner motor starts. High current draw can result in weak spark from transformer. Inspect ignitor and wiring. Check to assure positive contact between transformer terminals and electrode buss bars.
Problem G. Fuel oil odors.	
<ol style="list-style-type: none"> Oil or air leak in supply system. Down draft blowing out of barometric regulator. Improper flame adjustment. Delayed ignition. In adequate combustion air/ventilation. 	<ol style="list-style-type: none"> Tighten all fittings and check for leaking supply valve stems. <ol style="list-style-type: none"> Check for blocked chimney or vents. Check regulator setting and adjust to correct. Inspect flame through inspection port. Adjust burner air openings and/or fuel oil pressure. See F-2. See recommendations for outdoor air openings. Page 4.

Oil Burner Assembly

	Remedy
Problem A. Burner motor does not start.	
<ol style="list-style-type: none"> Incomplete electrical circuit. Primary control locked out on safety. Motor bearings frozen. Motor off/on thermoprotector. 	<ol style="list-style-type: none"> Check main disconnect switch, fuses, thermostat contacts, and operating and limit controls. Wait five minutes and until heat exchanger is cool. Actuate external reset on relay. Determine cause for lock-out and correct. Free shaft and lubricate. Allow motor to cool and push reset button. If motor cuts out again, check wiring to locate cause.

SERVICE & TROUBLESHOOTING

Oil Burner Assembly (Continued)

	Remedy
Problem B. Burner motor operates but no oil delivered at nozzle.	
<ol style="list-style-type: none"> Oil level below intake line inside supply tank. Clogged strainer. Clogged nozzle. Air leak in the intake line. Restricted intake lines (high vacuum). A two pipe system that becomes air bound. A single pipe system that becomes air bound. Slipping or broken coupling. Frozen fuel unit shaft. Excessive vacuum. Dirty oil filter cartridge. 	<ol style="list-style-type: none"> Fill tank with oil and bleed air from the line. Remove and clean strainer. Remove and clean or replace nozzle. Tighten all fittings in the intake line. Tighten unused intake port plug in the fuel unit. If there are valves in the line, be sure the valve stems are packed solid and tightened securely. Replace any kinked tubing and check all valves in the intake line. Insert by-pass plug if not in place. Prime pump. See start-up procedure. Tighten or replace coupling. Return unit to factory. Use next larger tubing size. Too high of a lift. Also see B5. Replace cartridge.
Problem C. Burner motor operates, delivers oil, but no flame.	
<ol style="list-style-type: none"> No spark. Poor atomization of oil. Improper electrode setting. Excessive combustion air. 	<ol style="list-style-type: none"> Check the ignitor and high tension insulators. Adjust oil pressure to 100 psi, check for oil line restriction and nozzle defects. Remove firing assembly and adjust. See start-up procedure.
Problem D. Burner starts but flame blows away from nozzle.	
<ol style="list-style-type: none"> Excessive combustion air. Excessive draft. Poor atomization of oil. Uneven flame. 	<ol style="list-style-type: none"> See start-up procedure. Adjust draft regulator. Change nozzle with same capacity. Change nozzle with same capacity.

Burner Fuel Unit

	Remedy
Problem A. No oil flow at nozzle.	
<ol style="list-style-type: none"> Oil level below intake line in supply tank. Clogged strainer or filter. Clogged nozzle. Air leak in intake line. Restricted intake line (high vacuum reading). A two-pipe system that becomes air bound. A single-pipe system that becomes air bound. Slipping or broken coupling. Rotation of motor and fuel unit is not the same as indicated by arrow on pad at top of unit. Frozen fuel unit shaft. 	<ol style="list-style-type: none"> Fill tank with oil. (Bleed air from oil lines.) Remove and clean strainer. Replace filter element. Replace nozzle. Tighten all fittings in intake line. Tighten unused intake port plug. Check filter cover and gasket. Replace any kinked tubing and check any valves in intake line. Check for correct line sizes. Check for and insert by-pass plug. Make sure return line is below oil level in tank. Loosen gauge port plug or easy flow valve and bleed oil for 15 seconds after foam is gone in bleed hose. Check intake line fittings for tightness. Check all pump plugs for tightness. Tighten or replace coupling. Install fuel unit with correct rotation. Return unit to approved service station or factory for repair. Check for water and dirt in tank.
Problem B. Oil leak.	
<ol style="list-style-type: none"> Loose plugs or fittings. Leak at pressure adj. screw or nozzle plug. Blown seal (single-pipe system). Blown seal (two-pipe system). Seal leaking. Cover loose. 	<ol style="list-style-type: none"> Dope with good quality oil-resistant thread sealer. Retighten. Washer may be damaged. Replace washer or O-ring. Check if by-pass plug has been left in unit. Replace fuel unit. Check for kinked tubing or other obstructions in return line. Replace fuel unit. Replace fuel unit. Tighten cover screws or replace damaged gasket.
Problem C. Noisy operation.	
<ol style="list-style-type: none"> Bad coupling alignment. Air in inlet line. Tank hum on two-pipe system and inside tank. 	<ol style="list-style-type: none"> Loosen fuel unit mounting screws slightly and shift unit in different positions until noise is eliminated. Retighten mounting screws. Check all connections. Use only good flare fittings. Install hum eliminator in return line.
Problem D. Pulsating pressure.	
<ol style="list-style-type: none"> Partially clogged strainer or filter. Air leak in intake line. Air leaking around cover. High vacuum. Should not exceed 17 inches Hg (mercury). 	<ol style="list-style-type: none"> Remove and clean strainer. Replace filter element. Tighten all fittings. Be sure strainer cover screws are tightened securely. Check for damaged cover gasket. Closed shut-off valve, clogged filter, kinked tubing, too small on line.
Problem E. Low oil pressure.	
<ol style="list-style-type: none"> Defective gauge. 	<ol style="list-style-type: none"> Check gauge against master gauge, or other gauge.
Problem F. Improper nozzle cut-off.	
<ol style="list-style-type: none"> Filter leaks. Strainer cover loose. Air pocket cut-off valve and nozzle. Air leak in intake line. Partially clogged nozzle strainer. Leak at nozzle adaptor. 	<ol style="list-style-type: none"> Check face of cover and gasket for damage. Tighten screws on cover. Run burner, stopping and starting unit, until smoke and after-fire disappears. Tighten intake fittings. Tighten unused intake port and return plug. Clean strainer or change nozzle. Change nozzle and adaptor.

WARRANTY

Seller warrants its products to be free from defects in material and workmanship, EXCLUSIVE, HOWEVER, of failures attributable to the use of materials substituted under emergency conditions for materials normally employed. This warranty covers replacement of any parts furnished from the factory of Seller, but does not cover labor of any kind and materials not furnished by Seller, or any charges for any such labor or materials, whether such labor, materials or charges thereon are due to replacement of parts, adjustments, repairs, or any other work done. This warranty does not apply to any equipment which shall have been repaired or altered outside the factory of Seller in any way so as, in the judgment of Seller, to affect its stability, nor which has been subjected to misuse, negligence, or operating conditions in excess of those for which such equipment was designed. This warranty does not cover the effects of physical or chemical properties of water or steam or other liquids or gases used in the equipment.

BUYER AGREES THAT SELLER'S WARRANTY OF ITS PRODUCTS TO BE FREE FROM DEFECT IN MATERIAL AND WORKMANSHIP, AS LIMITED HEREIN, SHALL BE IN LIEU OF AND EXCLUSIVE OF ALL OTHER WARRANTIES, EITHER EXPRESS OR IMPLIED, WHETHER ARISING FROM LAW, COURSE OF DEALING, USAGE OF TRADE, OR OTHERWISE, **THERE ARE NO OTHER WARRANTIES, INCLUDING WARRANTY OF MERCHANTABILITY OR FITNESS FOR PURPOSE, WHICH EXTEND BEYOND THE PRODUCT DESCRIPTION CONFIRMED BY BUYER AND SELLER AS OF THE DATE OF FINAL AGREEMENT.**

This warranty is void if the input to the product exceeds the rated input as indicated on the product serial plate by more than 5% on gas-fired and oil-fired units, or if the product in the judgment of SELLER has been installed in a corrosive atmosphere, or subjected to corrosive fluids or gases, been subjected to misuse, negligence, accident, excessive thermal shock, excessive humidity, physical damage, impact, abrasion, unauthorized alterations, or operation contrary to SELLER'S printed instructions, or if the serial number has been altered, defaced or removed.

Heat Exchangers

For Seller's non-separated combustion Gas-Fired Unit Heaters

BUYER'S REMEDY FOR BREACH OF WARRANTY, EXCLUSIVE OF ALL OTHER REMEDIES PROVIDED BY LAW, IS LIMITED TO REPAIR OR REPLACEMENT AT THE FACTORY OF SELLER, ANY HEAT EXCHANGER WHICH SHALL, WITHIN TEN YEARS FROM DATE OF FIRST BENEFICIAL USE BY BUYER OR ANY OTHER USER, WITHIN TEN YEARS FROM DATE OF RESALE BY BUYER OR ANY OTHER USER, WITHIN TEN YEARS FROM DATE OF RESALE BY BUYER IN ANY UNCHANGED CONDITION, OR WITHIN ONE HUNDRED TWENTY-SIX MONTHS FROM DATE OF SHIPMENT FROM SELLER, WHICHEVER OCCURS FIRST, BE RETURNED TO SELLER WITH TRANSPORTATION CHARGES PREPAID AND WHICH THE EXAMINATION OF SELLER SHALL DISCLOSE TO HAVE BEEN DEFECTIVE; EXCEPT THAT WHEN THE PRODUCT IS TO BE USED BY BUYER AS A COMPONENT PART OF EQUIPMENT MANUFACTURED BY BUYER, BUYER'S REMEDY FOR BREACH, AS LIMITED HEREIN, SHALL BE LIMITED TO ONE YEAR FROM DATE OF SHIPMENT FROM SELLER. FOR GAS-FIRED PRODUCTS INSTALLED IN HIGH HUMIDITY APPLICATIONS AND UTILIZING STAINLESS STEEL HEAT EXCHANGERS, BUYER'S REMEDY FOR BREACH, AS LIMITED HEREIN, SHALL BE LIMITED TO TEN YEARS FROM DATE OF SHIPMENT FROM SELLER.

For Seller's Low Intensity Gas-Fired Infrared Heaters

BUYER'S REMEDY FOR BREACH OF WARRANTY, EXCLUSIVE OF ALL OTHER REMEDIES PROVIDED BY LAW, IS LIMITED TO REPAIR OR REPLACEMENT AT THE FACTORY OF SELLER, ANY HEAT EXCHANGER WHICH SHALL, WITHIN FIVE YEARS FROM DATE OF FIRST BENEFICIAL USE BY BUYER OR ANY OTHER USER, WITHIN FIVE YEARS FROM DATE OF RESALE BY BUYER OR ANY OTHER USER, WITHIN FIVE YEARS FROM DATE OF RESALE BY BUYER IN ANY UNCHANGED CONDITION, OR WITHIN 66 MONTHS FROM DATE OF SHIPMENT FROM SELLER, WHICHEVER OCCURS FIRST, BE RETURNED TO SELLER WITH TRANSPORTATION CHARGES PREPAID AND WHICH THE EXAMINATION OF SELLER SHALL DISCLOSE TO HAVE BEEN DEFECTIVE; EXCEPT THAT WHEN THE PRODUCT IS TO BE USED BY BUYER AS A COMPONENT PART OF EQUIPMENT MANUFACTURED BY BUYER, BUYER'S REMEDY FOR BREACH, AS LIMITED HEREIN, SHALL BE LIMITED TO ONE YEAR FROM DATE OF SHIPMENT FROM SELLER.

Heat Exchanger (Condensers) for all Seller's products except non-separated combustion Gas-Fired Unit Heaters and Infrared Heaters, all Burners except Infrared Heaters, and Sheet Metal for all Seller's products BUYER'S REMEDY FOR BREACH OF WARRANTY, EXCLUSIVE OF ALL OTHER REMEDIES PROVIDED BY LAW, IS LIMITED TO REPAIR OR REPLACEMENT AT THE FACTORY OF SELLER, ANY HEAT EXCHANGER (CONDENSER) OR BURNER WHICH SHALL, WITHIN ONE YEAR FROM DATE OF FIRST BENEFICIAL USE BY BUYER OR ANY OTHER USER, WITHIN ONE YEAR FROM DATE OF RESALE BY BUYER IN ANY UNCHANGED CONDITION, OR WITHIN EIGHTEEN MONTHS FROM DATE

OF SHIPMENT FROM SELLER, WHICHEVER OCCURS FIRST, BE RETURNED TO SELLER WITH TRANSPORTATION CHARGES PREPAID AND WHICH THE EXAMINATION OF SELLER SHALL DISCLOSE TO HAVE BEEN DEFECTIVE; EXCEPT THAT WHEN THE PRODUCT IS TO BE USED BY BUYER AS A COMPONENT PART OF EQUIPMENT MANUFACTURED BY BUYER, BUYER'S REMEDY FOR BREACH, AS LIMITED HEREIN, SHALL BE LIMITED TO ONE YEAR FROM DATE OF SHIPMENT FROM SELLER.

Burners

For Seller's Low Intensity Gas-Fired Infrared Heaters

BUYER'S REMEDY FOR BREACH OF WARRANTY, EXCLUSIVE OF ALL OTHER REMEDIES PROVIDED BY LAW, IS LIMITED TO REPAIR OR REPLACEMENT AT THE FACTORY OF SELLER, ANY BURNER WHICH SHALL, WITHIN TWO YEARS FROM DATE OF FIRST BENEFICIAL USE BY BUYER OR ANY OTHER USER, WITHIN TWO YEARS FROM DATE OF RESALE BY BUYER IN ANY UNCHANGED CONDITION, OR WITHIN 30 MONTHS FROM DATE OF SHIPMENT FROM SELLER, WHICHEVER OCCURS FIRST, BE RETURNED TO SELLER WITH TRANSPORTATION CHARGES PREPAID AND WHICH THE EXAMINATION OF SELLER SHALL DISCLOSE TO HAVE BEEN DEFECTIVE; EXCEPT THAT WHEN THE PRODUCT IS TO BE USED BY BUYER AS A COMPONENT PART OF EQUIPMENT MANUFACTURED BY BUYER, BUYER'S REMEDY FOR BREACH, AS LIMITED HEREIN, SHALL BE LIMITED TO ONE YEAR FROM DATE OF SHIPMENT FROM SELLER.

For Seller's High Intensity Gas-Fired Infrared Heaters

BUYER'S REMEDY FOR BREACH OF WARRANTY, EXCLUSIVE OF ALL OTHER REMEDIES PROVIDED BY LAW, IS LIMITED TO REPAIR OR REPLACEMENT AT THE FACTORY OF SELLER, ANY BURNER WHICH SHALL, WITHIN TEN YEARS FROM DATE OF FIRST BENEFICIAL USE BY BUYER OR ANY OTHER USER, WITHIN TEN YEARS FROM DATE OF RESALE BY BUYER IN ANY UNCHANGED CONDITION, OR WITHIN 126 MONTHS FROM DATE OF SHIPMENT FROM SELLER, WHICHEVER OCCURS FIRST, BE RETURNED TO SELLER WITH TRANSPORTATION CHARGES PREPAID AND WHICH THE EXAMINATION OF SELLER SHALL DISCLOSE TO HAVE BEEN DEFECTIVE; EXCEPT THAT WHEN THE PRODUCT IS TO BE USED BY BUYER AS A COMPONENT PART OF EQUIPMENT MANUFACTURED BY BUYER, BUYER'S REMEDY FOR BREACH, AS LIMITED HEREIN, SHALL BE LIMITED TO ONE YEAR FROM DATE OF SHIPMENT FROM SELLER.

All Other Components Excluding Heat Exchanger (Condenser), Burner, and Sheet Metal

For all Seller's products except Direct-Fired Heaters and High Intensity Gas-Fired Infrared Heaters

BUYER'S REMEDY FOR BREACH OF WARRANTY, EXCLUSIVE OF ALL OTHER REMEDIES PROVIDED BY LAW, IS LIMITED TO REPAIR OR REPLACEMENT AT THE FACTORY OF SELLER, ANY PART OR PARTS WHICH SHALL, WITHIN TWO YEARS FROM DATE OF FIRST BENEFICIAL USE BY BUYER OR ANY OTHER USER, WITHIN TWO YEARS FROM DATE OF RESALE BY BUYER IN ANY UNCHANGED CONDITION, OR WITHIN THIRTY MONTHS FROM DATE OF SHIPMENT FROM SELLER, WHICHEVER OCCURS FIRST, BE RETURNED TO SELLER WITH TRANSPORTATION CHARGES PREPAID AND WHICH THE EXAMINATION OF SELLER SHALL DISCLOSE TO HAVE BEEN DEFECTIVE; EXCEPT THAT WHEN THE PRODUCT IS TO BE USED BY BUYER AS A COMPONENT PART OF EQUIPMENT MANUFACTURED BY BUYER, BUYER'S REMEDY FOR BREACH, AS LIMITED HEREIN, SHALL BE LIMITED TO ONE YEAR FROM DATE OF SHIPMENT FROM SELLER.

For Seller's Direct-Fired Heaters and High Intensity Gas-Fired Infrared Heaters

BUYER'S REMEDY FOR BREACH OF WARRANTY EXCLUSIVE OF ALL OTHER REMEDIES PROVIDED BY LAW IS LIMITED TO REPAIR OR REPLACEMENT AT THE SELLER'S OPTION ANY PART OR PARTS WHICH SHALL WITHIN A PERIOD OF ONE YEAR FROM DATE OF FIRST BENEFICIAL USE BY BUYER OR ANY OTHER USER, WITHIN ONE YEAR FROM DATE OF RESALE BY BUYER IN ANY UNCHANGED CONDITION, OR WITHIN 18 MONTHS FROM DATE OF SHIPMENT FROM SELLER, WHICHEVER OCCURS FIRST, BE RETURNED TO SELLER WITH TRANSPORTATION CHARGES PREPAID AND WHICH THE EXAMINATION OF THE SELLER SHALL DISCLOSE TO HAVE BEEN DEFECTIVE.

BUYER AGREES THAT IN NO EVENT WILL SELLER BE LIABLE FOR COSTS OF PROCESSING, LOST PROFITS, INJURY TO GOODWILL, OR ANY OTHER CONSEQUENTIAL OR INCIDENTAL DAMAGES OF ANY KIND RESULTING FROM THE ORDER OR USE OF ITS PRODUCT, WHETHER ARISING FROM BREACH OF WARRANTY, NONCONFORMITY TO ORDERED SPECIFICATIONS, DELAY IN DELIVERY, OR ANY LOSS SUSTAINED BY THE BUYER.

As Modine Manufacturing Company has a continuous product improvement program, it reserves the right to change design and specifications without notice. These appliances are certified for non-residential applications.

