

Harrington STORZ CONNECT



Fire Hydrant Conversion

HPHA™ *THREAD-ON* STORZ SPECIFICATION

The Storz Adapter is threaded onto the male hydrant nozzle and permanently secured with 2 SETSCREWS. The Storz cap is secured to the adapter with STAINLESS STEEL REFLECTIVE AIRCRAFT CABLE for night visibility. FOR SECURITY, the cap is resistant to removal by unauthorized personnel. Cap removal requires a Storz wrench. This is a Harrington feature called "HIGH TORQUE CAP REMOVAL".

Harrington maintains the integrity of fire hydrant adaptation from decades of experience.
Improving America's Emergency Response Connections.
American Innovation. American Made.

HPHA40-45NH/Cap - 4" Storz x 4.5" NH Female

HARRINGTON STORZ SPECIFICATION SHEET

HPHA40-45NH/Cap

Forged 6061-T6 Aluminum

- 4" Storz x 4 1/2" NH Female

Adapter with Metal Face Seal

- (2) Stainless Steel Setscrews
- Laser etched

- 4" Storz Cap with Stainless Steel Reflective Aircraft Cable

- Hard Anodized to Mil-A-8625f, Type 3, Dark Gray
- 250 psi working pressure

- MADE IN USA

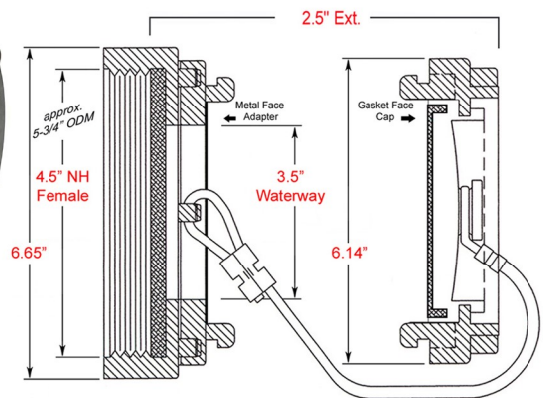

Specify HARRINGTON STORZ: HPHA40-45NH/Cap



Harrington
STORZ CONNECT

2630 West 21st Street
Erie, PA 16506

ph. 800-553-0078
info@harrinc.com



HPHA40-45NH/Cap

4" Storz Hydrant Adapter: 4 x 4 1/2" NH Female
w/(2) setscrews, Storz Cap and SS Cable

Date: 01/01/23

Weight: 5 lbs.

Specification / Data Sheet

Not to scale



NFPA 1963 COMPLIANT

HPHA