

## HPHA™ SPECIFICATION

The Harrington Permanent Hydrant Adapter threads onto the male nozzle and is secured permanently to the hydrant. A Storz spanner wrench is required for cap removal.

The Storz adapter shall have a hard anodized aluminum metal face seal and hard anodized aluminum Storz ramps and lugs. The adapter's finish shall be hardcoat anodized to Mil-A-8625, Type 3, dark gray. The Adapter shall be made of forged 6061-T6 aluminum and secured to the nozzle with (2) stainless steel set screws, inserted 180° apart. The female adapter shall contain a flat rubber gasket which seals against the male hydrant nozzle.

The blind cap shall have hard anodized aluminum Storz ramps and lugs, made of forged 6061-T6 aluminum. The forged cap shall be equipped with a Storz seal. The cap shall be connected to the adapter with a 0.125" vinyl coated aircraft cable. The high torque cap requires a Storz spanner wrench for removal. Once installed, the Harrington Permanent Hydrant Adapter extends less than 3" from the hydrant nozzle.

Specify: HARRINGTON "HPHA"

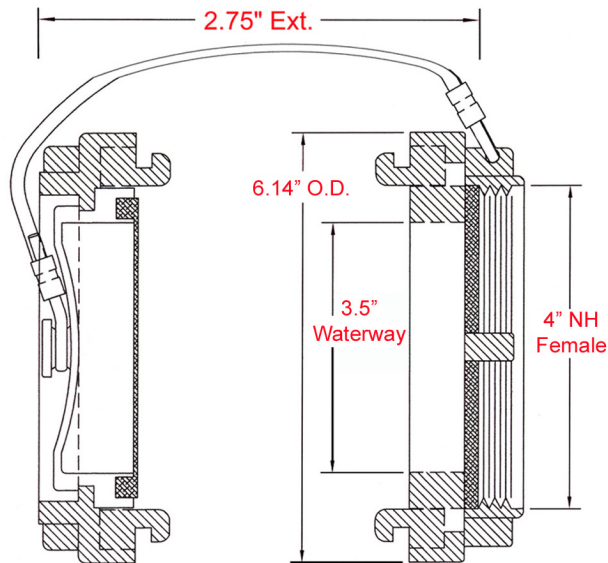
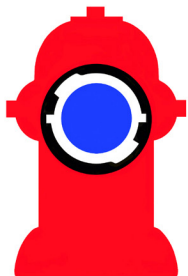

Harrington, Inc.  
2630 W. 21st St.  
Erie, PA 16506

Ph. 800-553-0078  
fax. 814-838-7339  
daveh@harrinc.com

DWG No.: **HPHA40-40NH/Cap**

Description: 4" Metal Face Storz x 4" NH Female  
w/ 4" Storz Cap w/ cable

Date: 04/08/10

DB: DTH

Rev.: 00

Scale: NTS

Sheet 1 of 1