

Class 125 3% Nickel Iron Body Check Valves

Bolted bonnet • renewable seat and disc* • stainless steel trim

200 PSI/13.8 bar non-shock cold working pressure to -20°F to 150°F/-29°C to 66°C†

Maximum working temperature 450°F/232°C at 125 PSI/8.6 bar

125 PSI/8.6 bar saturated steam to 353°F/178°C

CONFORMS TO MSS SP-71

MATERIAL LIST

PART	SPECIFICATION
1. Body Bolt ¹	Steel ASTM A307
2. Identification Plate	Aluminum
3. Bonnet	ASTM A126 3% Nickel Iron Class B
4. Body Gasket	Synthetic Fibers
5. Nut	Steel ASTM A563
6. Side Plug	ASTM A 193 B8M S31600SS
7. Hanger Pin	Ductile Iron ASTM A536
8. Hanger	Ductile Iron ASTM A395
9. Disc ²	ASTM A351 CF8M
10. Seat Ring	ASTM A351 CF8M
11. Disc Nut	ASTM A194 B8M S31600 SS
12. Body	ASTM A126 3% Nickel Iron Class B
13. Disc Bolt ²	ASTM A276 S31600 Stainless Steel

¹2" and 10" have hex head steel capscrew

²2"-4" SST ASTM A351 CF8M disc

⁵"-12" 3% nickel iron disc with SST disc face ring and disc bolt

DIMENSIONS—WEIGHTS—QUANTITIES

Size	Dimensions								Weight		
	A		B		D		E		Lbs.	Kg.	
In.	mm.	In.	mm.	In.	mm.	In.	mm.	In.	mm.		
2	50	8.00	203	3.94	100	6.00	152	.63	16	24	11
2½	65	8.50	216	4.50	114	7.00	178	.69	17	35	16
3	80	9.50	241	5.13	130	7.50	191	.75	19	47	21
4	100	11.50	292	6.13	156	9.00	229	.94	24	80	36
6	150	14.00	356	8.00	203	11.00	279	1.00	25	146	66
8	200	19.50	495	9.44	240	13.50	343	1.13	29	255	116
10	250	24.50	622	12.06	306	16.00	406	1.19	30	426	193
12	300	27.50	699	16.13	410	19.00	483	1.25	32	657	298

*Proper machining facilities required.

Note: On pump discharge, the preferred check valves are:

- inline, spring assisted, center-guided, lift checks
- spring assisted twin (double) disc
- swing design with lever and weight or lever and spring

Install 5 pipe diameters minimum downstream from pump discharge or changes in direction to avoid flow turbulence. Flow straighteners may be required in extreme cases.

NIBCO® Check Valves may be installed in both horizontal and vertical lines with upward flow or in any intermediate position.

Warning: Do not use for Reciprocating Air Compressor Service.



F-918-13
Flanged

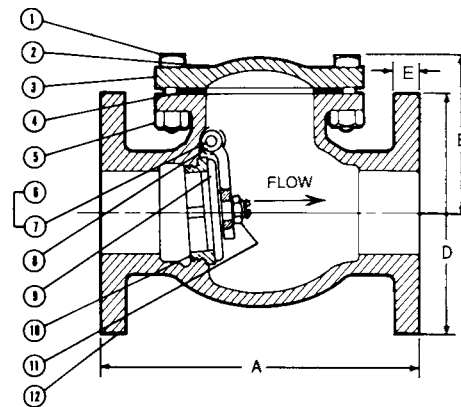

F-918-13
Flg x Flg