

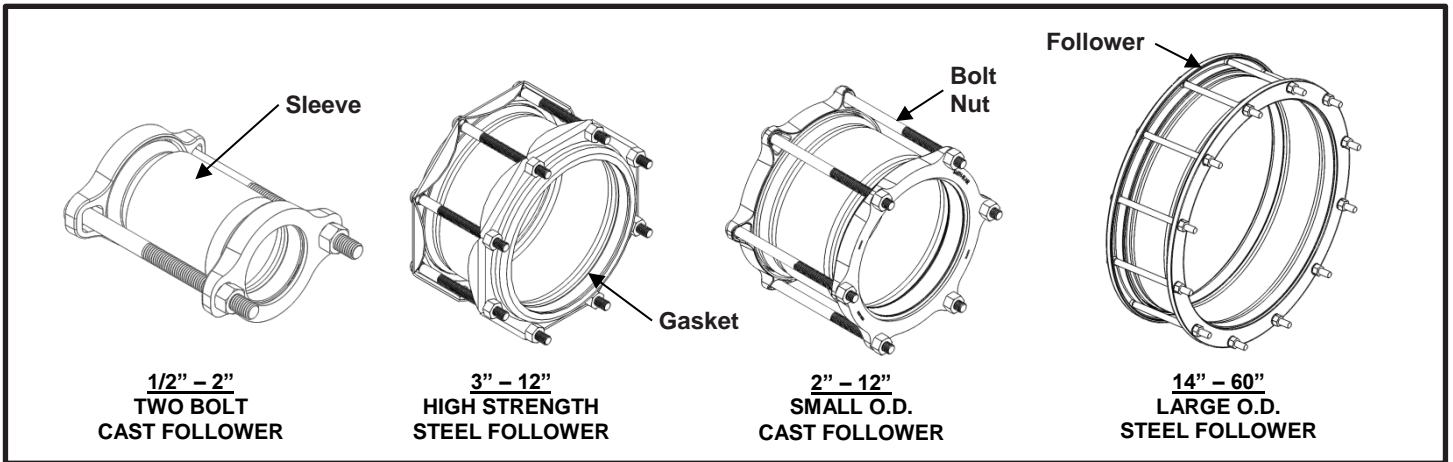

Smith-Blair
a xylem brand

SPECIFICATION STEEL COUPLING MODEL 411



APPLICATIONS

- **Typical Uses**
 - Joining plain-end pipe of same outside diameters
 - Replace split or excessively damaged pipe
- **Standard Pipe Sizes**
 - 1/2" to 60" nominal
- **Type of Pipe**
 - Carbon Steel, Stainless Steel, Ductile Iron, Asbestos Cement, PVC, HDPE (see notes), Copper
- **Working Pressure**
 - 1/2" – 16" nominal pipe size(s) = 300 psi
 - 18" – 36" nominal pipe size(s) = 250 psi
 - 42" nominal pipe size(s) and larger are rated based on application

MATERIALS

- **Followers** (*see catalog for specific follower design*)
 - **Cast Follower**
 - Cast using Ductile Iron 65-45-12 per ASTM A536
 - Flexi-Coat® fusion bonded epoxy finish
 - Permanently marked with part number and pipe size range
 - **Z-Section Follower**
 - HSLA Steel GR80 per ASTM A1011
 - Flexi-Coat® fusion bonded epoxy finish
 - **Steel Follower**
 - Carbon Steel C1020 per ASTM A576
 - Flexi-Coat® fusion bonded epoxy finish
- **Sleeve**
 - Material: 1/2" – 5" nominal pipe size(s) = Carbon Steel per ASTM A513 or A53
 - 6" – 60" nominal pipe size(s) = Carbon Steel per ASTM A283C
 - Flexi-Coat® fusion bonded epoxy finish
 - Larger O.D. sleeves provided with hanging ring(s)



Smith-Blair
a xylem brand

SPECIFICATION STEEL COUPLING MODEL 411

- **Gasket**
 - Nitrile (Buna-N) per ASTM D2000
 - Compounded to resist water, oil, natural gas, acids, alkalis, most (aliphatic) hydrocarbon fluids, and many other chemicals
 - Temperature range: -20°F to +180°F
 - For ductile iron and asbestos cement pipe sizes, the gaskets sealing surface has molded in ribs
 - Permanently marked with part number and pipe size range
- **Bolts**
 - Material: 1/2" hardware = Carbon Steel per ASTM A307
5/8" hardware = High Strength Low Alloy (HSLA) Steel per AWWA C111/A21.11
 - Coating: 1/2" hardware = Fe/Zn coated per ASTM F1941-10
5/8" hardware = None
 - Size: Steel Size(s) 1/2" – 2.00" = 1/2"-13UNC, Oval Neck Track Head with Rolled Threads
Steel Size(s) 2.38" – 24" = 5/8"-11UNC, Oval Neck Track Head with Rolled Threads
Cast/D. I. Size(s) 2" – 60" = 5/8"-11UNC, Oval Neck Track Head with Rolled Threads
- **Nut**
 - Material: 1/2" hardware = Carbon Steel per ASTM A307
5/8" hardware = HSLA Steel per AWWA C111/A21.11
 - Coating: 1/2" hardware = Fe/Zn coated per ASTM F1941-10
5/8" hardware = None
 - Size: Steel Size(s) 1/2" – 2.00" = 1/2"-13UNC, Heavy Hex Semi-Finished
Steel Size(s) 2.38" – 24" = 5/8"-11UNC, Heavy Hex Semi-Finished
Cast/D. I. Size(s) 2" – 60" = 5/8"-11UNC, Heavy Hex Semi-Finished

LISTINGS/STANDARDS

- Certified to NSF/ANSI 61 and NSF/ANSI 372
- Meets applicable portions of AWWA C219
- Flexi-Coat® Fusion-Bonded Epoxy Coating meets requirements of AWWA C213

OPTIONS

- Other materials of construction (e.g. 304SS, 316SS, etc.)
- Type 304 Stainless Steel hardware with fluoropolymer coated nuts to prevent galling
- Type 316 Stainless Steel hardware with fluoropolymer coated nuts to prevent galling
- Alternative gasket material (e.g. Viton, EPDM, etc.)
- Protected gasket (brass spring molded into leading edge)
- Anode connector
- Insulating boot(s)
- Anchor studs
- Pipe stops incorporated into sleeve
- Higher working pressure design
- Custom sleeve length and thickness
- Angled sleeve design (for deflections exceeding straight coupling deflection ranges)
- Transition gasket for undersized pipe
- Wall sleeve design (for building wall or bulkhead passage)



Smith-Blair
a xylem brand

SPECIFICATION STEEL COUPLING MODEL 411

NOTES

- Pipe stiffeners **are required** when this product is used on HDPE
- Xylem, Smith-Blair, SB stylized, and Flexi-Coat are registered trademarks of Xylem, Inc., or one of its subsidiaries.
- These product specifications were correct at the time of publication and are subject to change without notice
- See the Smith-Blair website for part numbers and ordering information
- See the Smith-Blair website for warranty information
- See the Smith-Blair website for corrosion notice

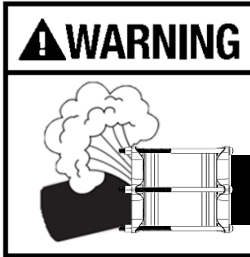

THIS PRODUCT DOES NOT RESTRAIN PIPE MOVEMENT. Proper anchoring is required to prevent pipe pull out. Failure to anchor or improper anchoring can result in dangerous pipe content escape, property damage, serious injury, and/or death. Read the product installation instructions prior to installing this product.



Smith-Blair
a xylem brand

SPECIFICATION STEEL COUPLING MODEL 411

Recommended Pipe to Pipe Centerline Gaps

Sleeve Length	Optimum Gaps		Maximum Gap
	Straight Run	Deflected Joints	
5"	1/2"	1"	2"
7"	1"	1-1/2"	3"
10"	1"	2-1/4"	4-1/2"
Longer Than 10"	1"	2-3/4"	"Sleeve Length" – 6"

Pipe gap to be centered in coupling sleeve.

Total Maximum Allowable Axial Pipe Movement per Coupling

Nominal Pipe Size	Allowable Movement
1/2" to ≤ 2"	1/8"
> 2" to ≤ 10"	1/4"
> 10"	3/8"

Pipe End Tolerances

Nominal Pipe Size	Minus Tolerance	Plus Tolerance
1/2" to ≤ 16"	-0.06	+0.06
> 16" to ≤ 24"	-0.08	+0.08
> 24" to ≤ 42"	-0.10	+0.10
> 42"	-0.06	+0.12

Maximum Angular Deflection per Coupling

Nominal Pipe Size	Center Sleeve Length		
	5"	7"	10" and Larger
1/2" to ≤ 2"	7°	7°	7°
> 2" to ≤ 12"	4°	4-1/2°	4-1/2°
> 12" to ≤ 24"	2-1/2°	4°	4-1/2°
> 24" to ≤ 36"	-	3-1/2°	4°
> 36" to ≤ 42"	-	3°	3-1/2°
> 42" to ≤ 60"	-	2-1/2°	3°
> 60" to ≤ 80"	-	-	2-1/2°
> 80" to ≤ 100"	-	-	2°
> 100"	-	-	-

30 Globe Ave, Texarkana, AR 71854
Ph: 870-773-5127 • Fax: 870-773-5212
Toll-Free Numbers: Ph: 800-643-9705 • Fax: 800-648-6792

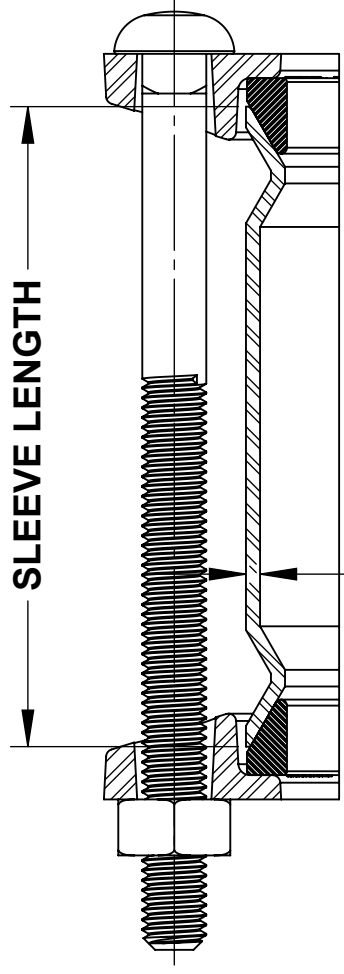

SLEEVE THICKNESS

SECTION A-A

**1/2" - 2"
TWO BOLT
CAST FOLLOWER**

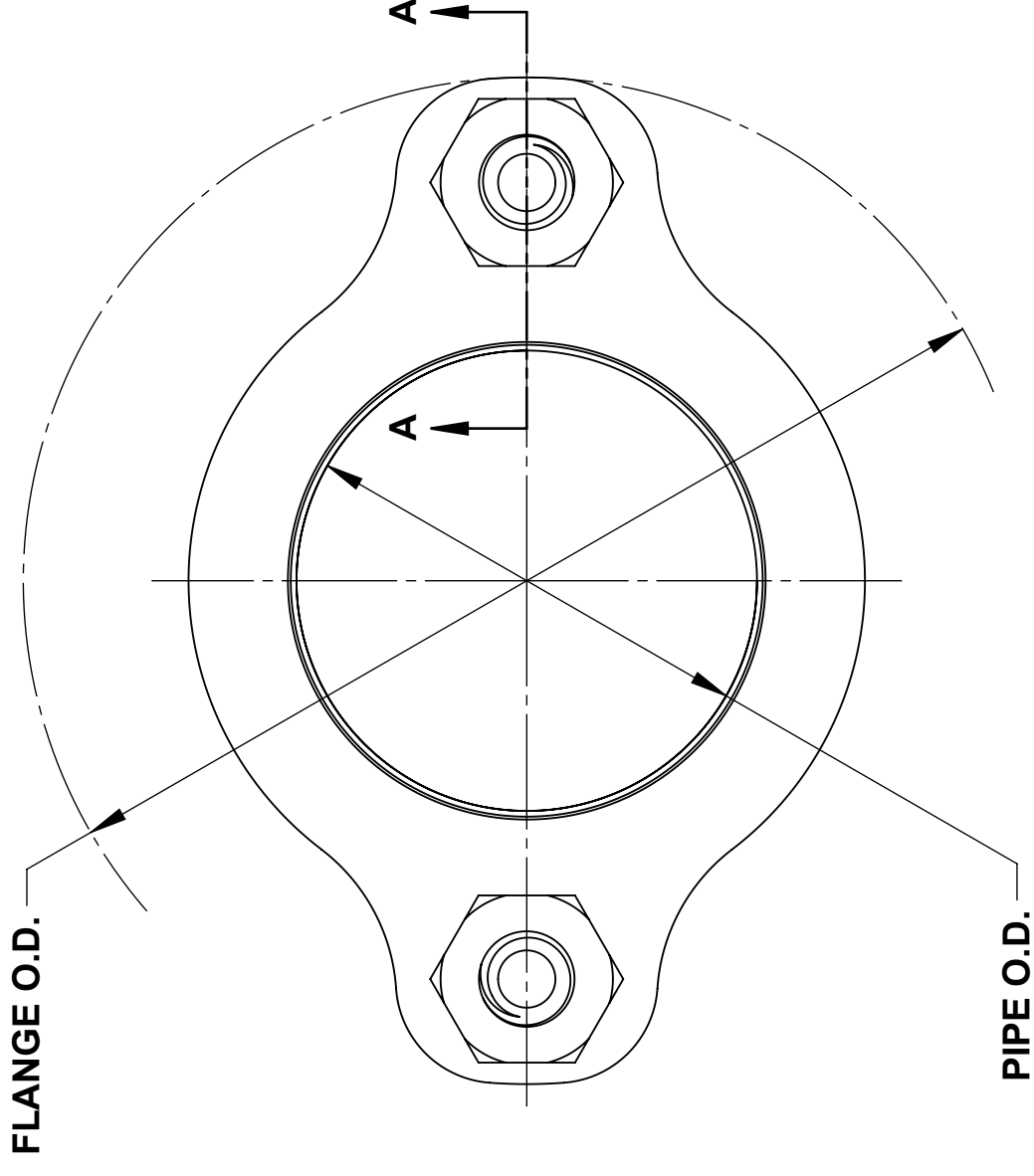

FLANGE O.D.

PIPE O.D.

NOTES:

- SEE SMITH-BLAIR CATALOG FOR FLANGE O.D., BOLT QTY & SLEEVE THICKNESS/LENGTH DESIGN CALLOUTS
- 2" STEEL SIZE STANDARD SLEEVE LENGTH COUPLING SHOWN OTHER SIZES SIMILAR

WRENCH SIZE CHART

NUT	SIZE
1/2"-13UNC HH	7/8"
5/8"-11UNC HH	1-1/16"

TOLERANCES U.N.O. XX= ±.03 XXX= ±.015 FRACTIONS= * ANGLES= ±1° MACH. FIN=	NOTES: REMOVE BURRS AND SHARP EDGES DO NOT SCALE DWG.	APP'D	DATE
SCALE: N/A	DRN	CHD	DATE
ALL DIMENSIONS ARE IN INCHES.			1/13/16

TITLE
SPECIFICATION
STEEL COUPLING
MODEL 411

SMITH-BLAIR
 TEXARKANA, ARKANSAS

P/N N/A

SPEC_411.DRW

DWG. NO.

5 OF 7
SHEET

5/1/18
REV.

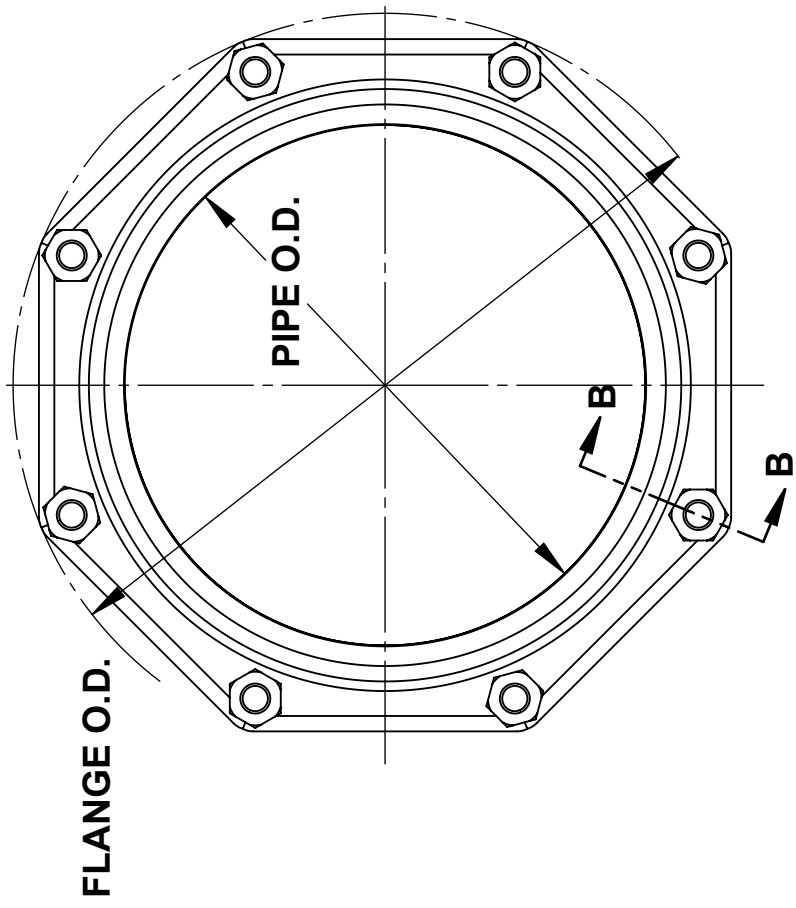

**3" - 12"
HIGH STRENGTH
STEEL FOLLOWER**

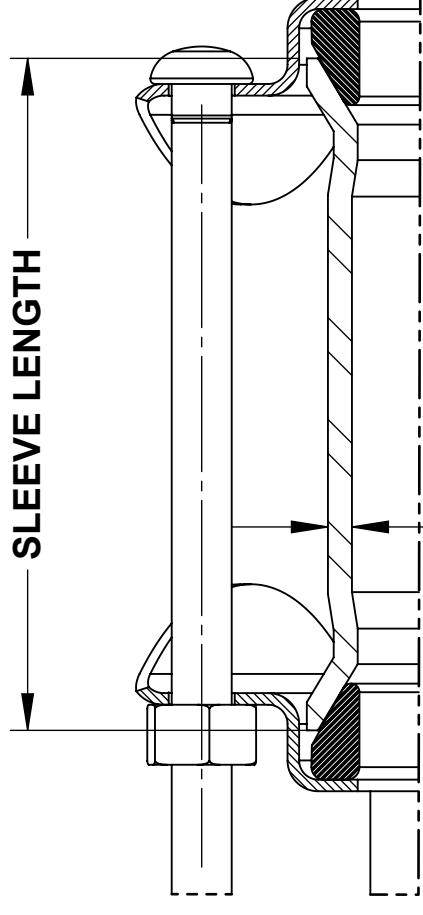

SLEEVE THICKNESS
SECTION B-B

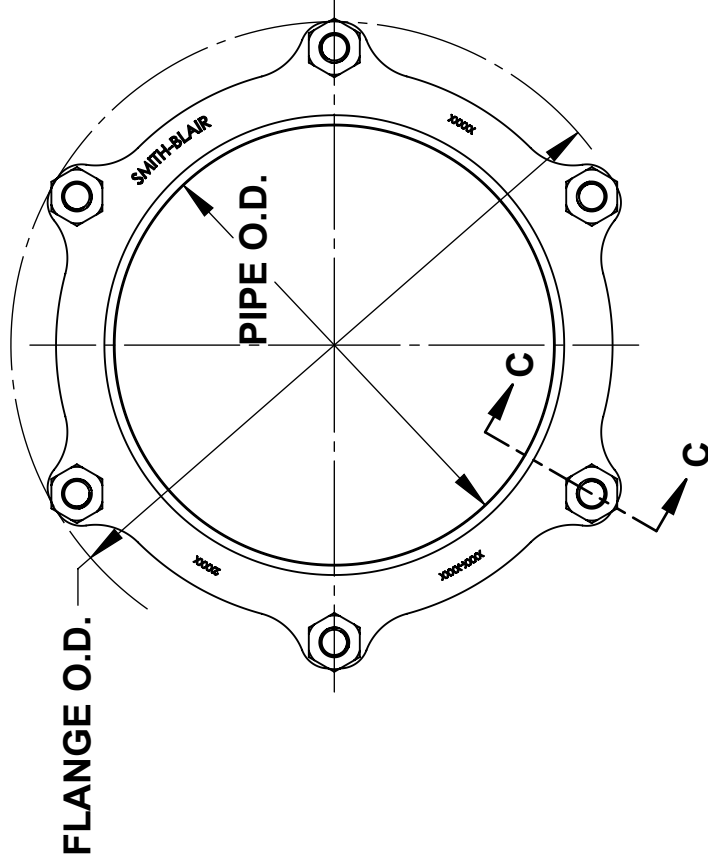

**2" - 12"
SMALL O.D.
CAST FOLLOWER**

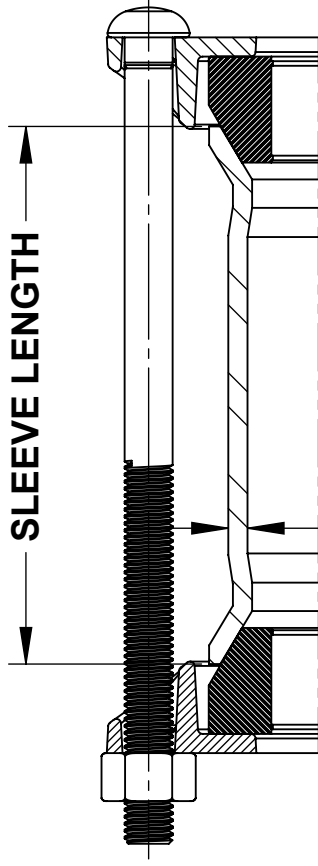

SLEEVE THICKNESS
SECTION C-C

- NOTES:**
- SEE SMITH-BLAIR CATALOG FOR FLANGE O.D., BOLT QTY & SLEEVE THICKNESS/LENGTH DESIGN CALLOUTS
 - 10" Z-SECTION STEEL SIZE AND 8" D.I. SIZE STANDARD SLEEVE LENGTH COUPLINGS SHOWN OTHER SIZES SIMILAR

WRENCH SIZE CHART	
NUT	SIZE
5/8"-11UNC HH	1-1/16"

TOLERANCES U.N.O. XX= +.03 XXX= +.015 FRACTIONS= ANGLES=+1° MACH. FIN.	NOTES: REMOVE BURRS AND SHARP EDGES DO NOT SCALE DWG.	APP'D	DATE
SCALE: N/A	DRN	CHD	DATE
ALL DIMENSIONS ARE IN INCHES.			1/13/16

TITLE
SPECIFICATION
STEEL COUPLING
MODEL 411

SMITH-BLAIR TEXARKANA, ARKANSAS	P/N	N/A
	DWG. NO.	SPEC_411.DRW
REV.		5/1/18
SHEET		6 OF 7

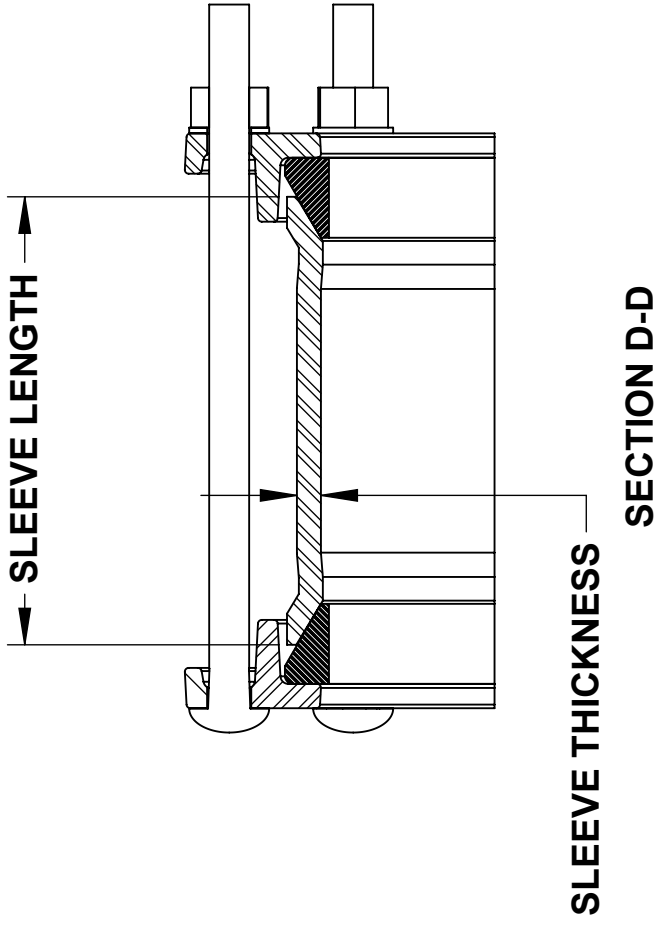

**14" - 60"
LARGE O.D.
STEEL FOLLOWER**

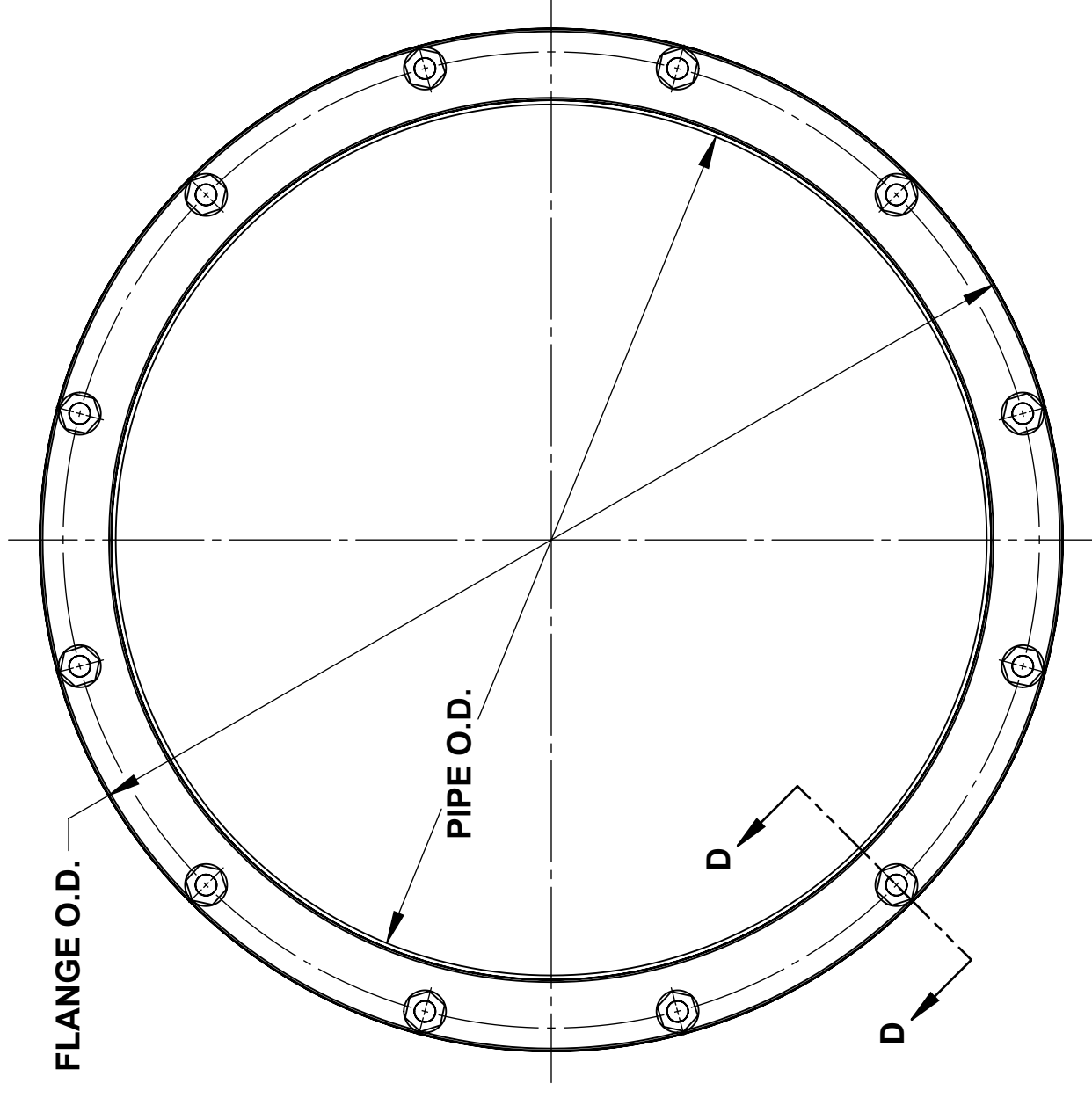

- NOTES:**
- SEE SMITH-BLAIR CATALOG FOR FLANGE O.D., BOLT QTY & SLEEVE THICKNESS/LENGTH DESIGN CALLOUTS
 - 24" STANDARD SLEEVE LENGTH COUPLING SHOWN OTHER SIZES SIMILAR

WRENCH SIZE CHART	
NUT	SIZE
5/8"-11UNC HH	1-1/16"

TOLERANCES U.N.O. XX= ±.03 XXX= ±.015 FRACTIONS= ±.015 ANGLES= ±1° MACH. FIN=	NOTES: REMOVE BURRS AND SHARP EDGES DO NOT SCALE DWG.	APP'D	DATE
SCALE: N/A	DRN	CHD	DATE
ALL DIMENSIONS ARE IN INCHES.			1/13/16
TITLE SPECIFICATION STEEL COUPLING MODEL 411			
SMITH-BLAIR TEXARKANA, ARKANSAS		P/N	N/A
DWG. NO. SPEC_411.DRW		7	5/1/18
		OF	7
		SHEET	REV.