

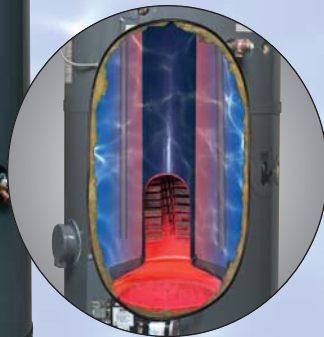

Oil-Fired Water Heaters Residential/Light Commercial: Single-Flue



**Patented Turboflue®
heat exchanger**

Providing quality in construction, efficiency in performance and durability in operation has earned Bock a bit of a reputation: we're recognized as the leader in oil-fired water heaters.

Whatever your hot water needs, there's a Bock, just right for you:

Bock water heaters are perfect for all residential applications, particularly those with high-volume hot water demands. Today's homes not only require a dependable and economic hot water source for traditional uses like dishwashing, laundering and cleaning, but also one that offers fast recoveries to meet the demands of more sophisticated shower systems, whirlpools and radiant flooring systems

In commercial and industrial applications; from light demand to continuous-use requirements, our outstanding recovery capabilities make Bock water heaters ideal for multi-dwelling units (MDUs - apartments, dormitories), place of worship, hospitality (hotels, motels), health care (hospitals, clinics, assisted living facilities), athletic facilities, (health clubs, spas, swimming pools), hair salons and beauty shops, farms (dairy barns), office buildings, correctional facilities, laundries, car washes, food service, schools and many more.

- ◆ **Turboflue®** - Bock's patented design is the industry's most advanced and efficient heat exchanger. Simply put, it heats water faster and uses less fuel, which reduces energy costs.
- ◆ **C-glass®** - Durable and exclusive porcelain enamel glass is used to line all tanks and Turboflues. Highly resistant to aggressive water. Fresh silica mixed daily to provide the highest quality.
- ◆ **Built to last** - Hand-crafted from heavy gauge steel. Longer life equals a higher "Return on Investment".
- ◆ **Dual magnesium anode rods** - Inhibit corrosion and maximize tank life. Electrolysis attacks the anode rods, not the welded seams of the tank.
- ◆ **Double pressure tested** - Only Bock pressure tests its tanks twice.
- ◆ **Fully welded tank skirt** - prevents noxious flue gases from escaping between the tank and jacket.
- ◆ **Center flue design** - reduces tank flex for longer life.
- ◆ **Fiberglass insulation** - decreases standby heat loss.
- ◆ **Accurate temperature control** - Only Bock offers dual aquastats or operating and high limits, as standard.
- ◆ **Spring loaded inspection door** - Easy access for inspection and maintenance, also functions as a pressure relief valve.
- ◆ **Brass drain valve** - accessible.
- ◆ **Factory installed T&P valve** - CSA listed.
- ◆ **Hand-cast refractory lined combustion chamber** - Only one in the industry - better heat retention, warmer starts, better combustion, reduces noxious emissions.
- ◆ **UL listed.**
- ◆ **ASME construction** - available on selected models.
- ◆ **Externally mounted burner** - provides easy installation and maintenance.
- ◆ **5 year limited warranty** - on steel tank (single family residential installations).
- ◆ **3 year limited warranty** - on steel tank (commercial installations).

Quality Crafted Hot Water Solutions!



Oil-Fired Water Heaters Residential/Light Commercial: Single-Flue

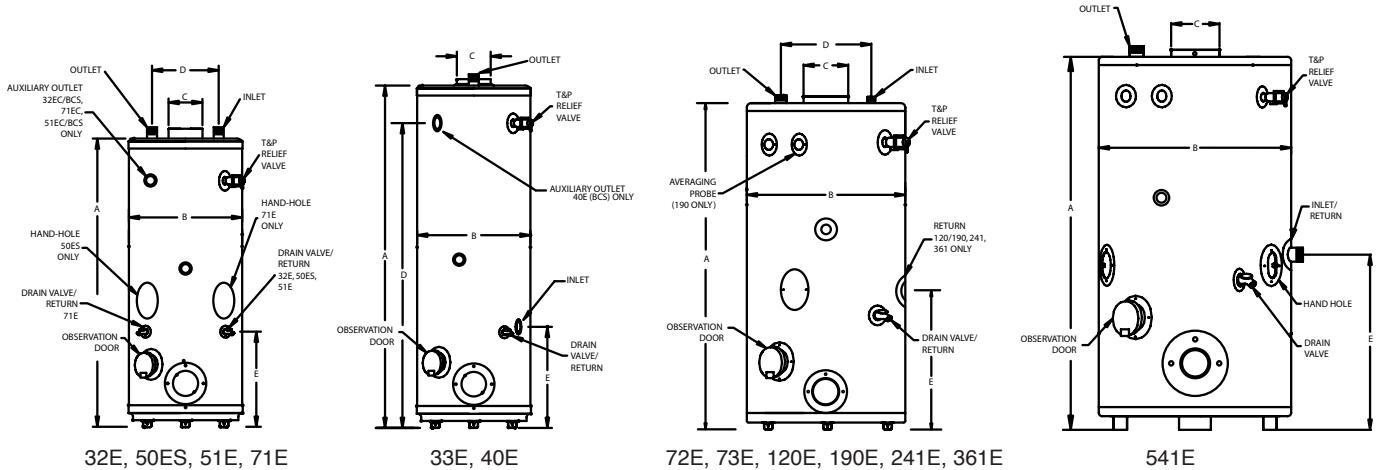

Model	Storage (gal)	Rated Input		Recovery @ Δ 90°F (GPH)	Max. Temp. Setting (°F)	Inlet Pipe Dia.	Outlet Pipe Dia.	Return Pipe Dia.	Dimensions					Shipping Weight (lbs)***	
		BTU/HR	GPH						A	B	C	D	E	Standard	ASME
32E	32	104,000	0.75	114	160	3/4"	3/4"	3/4"	51"	20"	6"	11"	17"	272	-
33E	33	104,000	0.75	111	160	3/4"	3/4"	3/4"	43-1/4"	24"	6"	N/A	17-1/4"	278	-
40E	40	126,000	0.90	136	160	3/4"	3/4"	1"	61"	20"	6"	54"	18"	301	-
50ES	50	140,000	1.00	151	160#	1"	1-1/2" **	1-1/2"	52"	26"	6"	13-1/2"	18-1/2"	369	-
51E	50	152,000	1.10	161	160#	1"	1"	3/4"	59"	24"	6"	11"	18"	330	-
71E	68	173,000	1.25	177	160#	1"	1 1/2" **	1-1/2"	66"	26"	6"	13-1/2"	22"	438	-
72E	67	199,000	1.50	212	160#	1"	1-1/2" **	1-1/2"	58"	28"	8"	16"	N/A	503	-
73E	67	242,000	1.75	258	180	1"	1-1/2" **	1-1/2"	58"	28"	8"	16"	N/A	503	-
120E	113	155,000	1.10	163	180	1"	2" **	2"	67"	31-1/2"	6"	19"	22"	709	-
190E	113	190,000	1.35	199	180	1"	2" **	2"	67"	31-1/2"	6"	19"	22"	709	-
241E*	109	277,000	2.00	286	180	1"	2" **	2" **	67"	31-1/2"	8"	19"	22"	856	912
361E*	91	415,000	3.00	443	180	1"	2" **	2" **	67"	31-1/2"	9"	23"	26"	1,014	1,050
541E*	83	623,000	4.50	648	180	2"	2" **	2" **	66"	34"	10"	22"	30-1/2"	1,232	1,258

* ASME models available
 ** Nipple not included
 *** Weight does not include burner and controls
 # Optional settings, contact factory



(on selected models)

WARNING: Do not install on combustible flooring. Installation should be in accordance with all national and/or local codes. In the absence of local codes, refer to NFPA 54 or ANSI Z.21.10.1.

CAUTION: The recommended maximum hot water temperature setting for normal residential use is 120°F. Bock recommends a tempering valve or anti-scald valve be installed and used according to the manufacturer's directions to prevent scalding.

Pressures (all): Test pressure, 300 psi; working pressure, 150 psi

Standard Voltage (all): 120V, 60 Hz, 1P

T&P valve installed

All Bock products meet or exceed current ASHRAE standards.

For additional information and sample specifications, please visit our website - www.bockwaterheaters.com

◆ www.bockwaterheaters.com ◆
 ◆ 110 South Dickinson Street ◆ Madison, Wisconsin 53703 ◆
 ◆ Toll Free 800.794.2491 ◆ Phone 608.257.2225 ◆ Fax 608.257.5304 ◆