

**Horizon
MEDICINE CABINET**

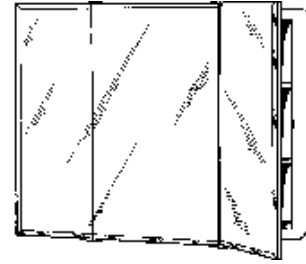

FEATURES/TYPICAL SPECIFICATIONS

- Recess Mount Installation
 - Wall Opening/Rough-in Dimensions: 27³/₄" x 24³/₄" x 3¹/₂"
- Formed and welded steel housing (WB/ST)
 - 24 gauge steel construction with white heat cured, acrylic paint finish
- Frameless mirror doors (3 typical)
 - 3/16" thick float glass mirrors with 1/2" beveled edges, around perimeter of 3 assembled mirrors
 - 10" wide mirror doors
 - 24 gauge steel, pan formed, door back with white, heat cured, acrylic paint finish
- 90° concealed hinge (HG05) (6 typical)
- 26 gauge galvanized steel shelves, adjustable (ADJ) (2 typical)
- Includes installation hardware
- Standard Pallet Quantity of 14 units

Finishes:

Housing: PT01—Basic White
 Mirror: 1/2 BVL—1/2" Bevel Edge
 Frame: Frameless

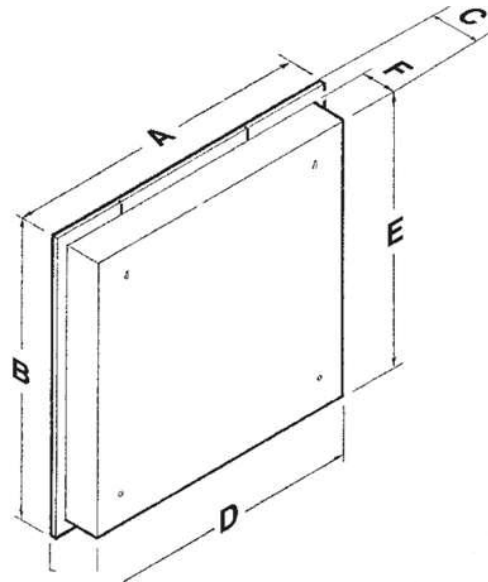

Model #	Description	DIMENSIONS IN INCHES*					
		A	B	C	D	E	F
255030	Horizon 3DR 30x28 BVL WB/ST ST	30	28 ¹ / ₄	5	27 ³ / ₄	24 ³ / ₄	3 ¹ / ₂

REFERENCE	QTY.	REMARKS	Project
			Location
			Architect
			Engineer
			Contractor
			Submitted by
			Date

* All models and material specifications are subject to change or withdrawal without notice.