

### Styleline MEDICINE CABINET

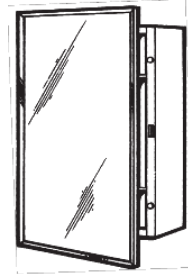

#### FEATURES/TYPICAL SPECIFICATIONS

- Surface Mount Installation
  - Pre-drilled mounting holes spacing: y = 12.375" center-to-center and x = 8.875" center-to-center
- Formed and welded steel housing (WB/ST)
  - 24 gauge steel construction with white, heat cured, acrylic paint finish
- Framed mirror door
  - Polished Stainless Steel frame (SS8)
  - 2mm thick float glass mirror door front
  - 30 gauge steel door back with white, heat cured, acrylic paint finish
- 16" piano hinge welded to the door and mechanically fastened to the cabinet body (HG01) (1 typical)
- Magnetic catch in cabinet body flange aligns to stainless steel striker plate on the door (1 typical)
- Reversible for left-hand or right-hand door swing
- 26 gauge galvanized steel shelves with white, heat cured, enamel paint finish (2 typical)
  - Adjustable Shelves (ADJ)
- Mounting hardware included
- Pallet quantity = 36 units

#### Finishes:

- Housing: PT01—Basic white  
 Mirror: Flat Mirror  
 Frame: SS8—Polished Stainless Steel

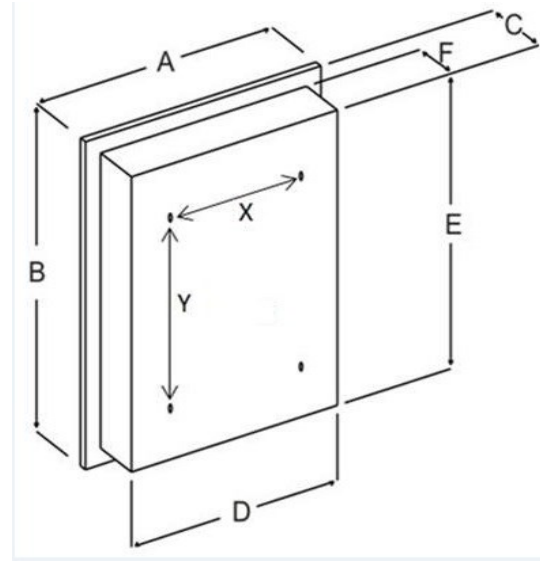

Model #	Description	Dimensions In Inches					
		A	B	C	D	E	F
452SM	MEDCAB 1DR 16X22 SS8 WB/ST	16.125	22.125	4.750	15.500	21.500	4.342

REFERENCE	QTY.	REMARKS	Project
			Location
			Architect
			Engineer
			Contractor
			Submitted by
			Date

\* All models and material specifications are subject to change or withdrawal without notice.