

Mirage MEDICINE CABINET



FEATURES/TYPICAL SPECIFICATIONS

- Recess Mount Installation
 - Wall Opening/Rough-in Dimensions 14" x 24" x 3 1/2"
- One piece drawn steel housing (HY/ST)
 - 26 gauge steel with white, heat cured, acrylic paint finish
- Frameless mirror door
 - 5/32" thick float glass octagon mirror door front with 1/2" beveled edges (1/2 BVL)
 - 24 gauge steel door back with white, heat cured, acrylic paint finish
- 16" piano hinge welded to the door and mechanically fastened to the cabinet body (HG01) (1 typical)
- Magnetic catch in cabinet body flange aligns to stainless steel striker plate on the door (1 typical)
- Reversible for left-hand or right-hand door swing
- 26 gauge galvanized steel shelves with white, heat cured, enamel paint finish, adjustable (ADJ) (2 typical)
- Includes installation hardware
- Pallet Quantity = 24 units

Finishes:

Housing: PT01—Basic White
 Mirror: 1/2 BVL -1/2" Bevel Edge
 Frame: Frameless

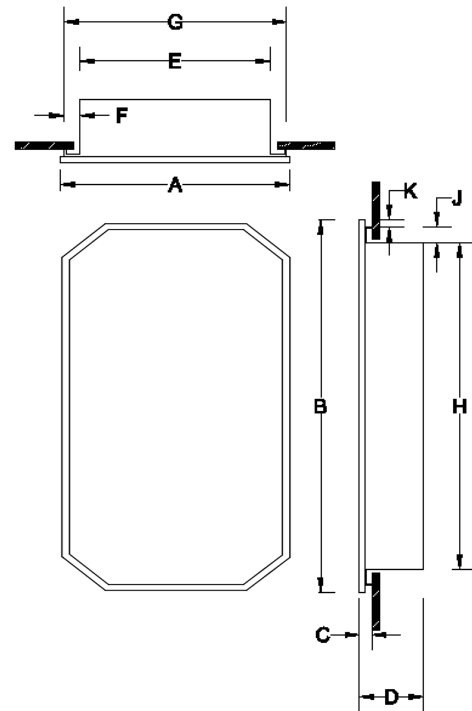

		Dimensions In Inches									
Model #	Description	A	B	C	D	E	F	G	H	J	K
1456	MEDCAB 1DR 17X32 FMLS HY/ST	17 1/4	32	1 1/2	4 1/2	13 1/2	1	15 1/2	23 1/2	1	3 1/4

REFERENCE	QTY.	REMARKS	Project
			Location
			Architect
			Engineer
			Contractor
			Submitted by
			Date

* All models and material specifications are subject to change or withdrawal without notice.