

COMMERCIAL AIR HANDLERS (3 PHASE) 6 to 20 TON

REFRIGERATION CIRCUIT

- Standard factory-installed thermostatic expansion valves (TXVs) on BAC units; BHC units include TXVs and check valves for heat pump applications.
- Cooling coils with mechanically bonded fins provide peak heat transfer.

BUILT TO LAST

- Die-formed galvanized steel casings provide durability and structural integrity.
- Insulation and drain pan contains an immobilized anti-microbial agent to inhibit the growth of bacteria and fungi.

EASY TO INSTALL AND SERVICE

- High static design meets a wider range of applications than competitive packaged air handler lines.
- Multiposition design can be installed horizontally or vertically without modification.
- Drain pan can be adjusted for a right or left hand connection to provide positive drainage and prevent standing condensate.
- The two in. (51 mm) factory installed disposable filters remove dust and airborne particles from the occupied space to serviceable components.
- Easy installation and maintenance; removal of one side panel allows access to serviceable components.

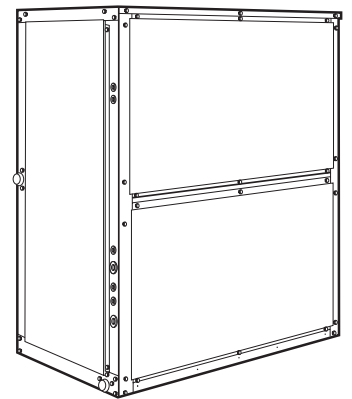

ELECTRIC HEAT

- 5 - 50 kW

WARRANTY

- 1 year parts limited warranty.



BAC UNIT PERFORMANCE DATA (3 Phase / 60 Hz)

Model Number	Nominal Capacity Tons	Nominal Airflow	Airflow Range	Voltage	Unit Dimensions H X W X L	Operating Weight (LB)
BAC075***	6	2400	1800 - 3000	208 /230 or 460	56" X 29" X 48"	381
BAC090***	7-1/2	3000	2250 - 3750	208 /230 or 460	56" X 29" X 48"	385
BAC120***	10	4000	3000 - 5000	208 /230 or 460	56" X 29" X 48"	405
BAC150***	12-1/2	5000	3750 - 6250	208 /230 or 460	56" X 29" X 89"	670
BAC180***	15	6000	4500 - 7500	208 /230 or 460	56" X 29" X 89"	685
BAC240/245***	20	8000	6000 - 10000	208 /230 or 460	56" X 29" X 89"	690

BHC UNIT PERFORMANCE DATA (3 Phase / 60 Hz)

Model Number	Nominal Capacity Tons	Nominal Airflow	Airflow Range	Voltage	Unit Dimensions H X W X L	Operating Weight (LB)
BHC090***	7-1/2	3000	2250 - 3750	208 /230 or 460	56" X 29" X 48"	385
BHC120***	10	4000	3000 - 5000	208 /230 or 460	56" X 29" X 48"	427
BHC180***	15	6000	4500 - 7500	208 /230 or 460	56" X 29" X 89"	713

*** M = 208/230/460-3-60, H = 208/230-3-60, L = 460-3-60, S = 575-3-60
 1 = Medium Static Drive, 2 = High Static Drive
 A = Standard or Alternate Motor, B = Standard Motor, Standard Drive Only.

508 21 1501 04

ADDITIONAL FEATURES:

Cooling coils prevent the build-up of humidity in the room, even during part-load conditions. Unit sizes of 10 tons and above feature dual-circuit face-split coils.

Economy

All packaged air handlers have low initial costs, and they continue to save money by providing reduced installation expense and energy-efficient performance.

Quick installation is ensured by the multiposition design. Units can be installed in either the horizontal or vertical (upflow) configuration without modifications. All units have drain-pan connections on both sides, and pans can be pitched for right- or left-hand operation with a simple adjustment. Fan motors and contactors are pre-wired and TXVs are factory-installed on all models.

High efficiency, precision-balanced fans minimize air turbulence, surging, and unbalanced operation, thereby cutting operating expenses.

Economizer accessory precisely controls the blend of outdoor air and room air to achieve comfort levels. When the outside air enthalpy is suitable, outside air dampers can fully open to provide “free” cooling.

Rugged dependability

Die-formed galvanized steel panels ensure structural integrity under all operating conditions.

Galvanized steel fan housings are securely mounted to a die-formed galvanized steel deck.

Rugged pillow-block bearings (12-1/2 to 20 Ton) are securely fastened to the solid steel fan shaft with split collets and clamp locking devices. Smaller unit sizes have spider-type bearings.

Coil flexibility

All models (direct-expansion coils) and have galvanized steel casings; inlet and outlet connections are on the same end.

Direct expansion (DX) coils are designed for use with Refrigerant 22 and have copper tubes mechanically bonded to aluminum sine-wave fins. Direct-expansion coils include matched, factory-installed thermostatic expansion valves (TXVs) with matching distributor nozzles.

Easier installation and service

The multi-position design and component layout help you to get the unit installed and running quickly. The DX coils have factory-installed TXVs with matching distributor nozzles. Units can be converted from horizontal to vertical operation by simply repositioning the unit. Drain pan connections are duplicated on both sides of the unit. The filters, motor, drive, TXVs, and coil connections are easily accessed by removing a single side panel.

Table of contents

	Page
Features/Benefits	1,2
Model Number Nomenclature	3
Physical Data	4-7
Options and Accessories	8-9
Dimensions	10-16
Performance Data	17-29
Electrical Data	30-37
Accessories	38
Guide Specifications	39-40

MODEL NUMBER IDENTIFICATION GUIDE

MODEL NUMBER	B	H	C	090	M	1	A = Standard or Alternate Motor B = Standard motor. Standard Drive Only
PRODUCT FAMILY Air Handler Units							
TYPE H= Heat Pump A = Air Conditioner							BLOWER DRIVE OPTIONS 1 = Medium Static Drive 2 = High Static Drive
DESIGN SERIES							VOLTAGE H = 208/230-3-60 . . . M = 208/230/460-3-60 L = 460-3-60 S = 575-3-60
							COOLING CAPACITY (NOMINAL BTUH) 075 = 6 Ton 090 = 7-1/2 120 = 10 Ton 150 = 12-1/2 Ton 180 = 15 Ton 240 = 20 Ton 245 = 20 Ton, High Efficiency

UNIT SIZE AVAILABILITY BY CAPACITY - Ton

UNIT	6	7-1/2	10	12-1/2	15	20
BAC	X	X	X	X	X	X
BHC		X	X		X	

MODEL NUMBERS

AIR CONDITIONER MODELS Standard Motor - Med. Static	AIR CONDITIONER MODELS Alternate Motor - High Static	HEAT PUMP MODELS Standard Motor - Med. Static	HEAT PUMP Alternate Motor - High Static
BAC075M1A	BAC075M2A	BHC090M1B *	-
BAC075S1A	BAC075S2A	BHC090S1B *	-
BAC090M1A	BAC090M2A	BHC090M1A	BHC090M2A
BAC090S1A	BAC090S2A	BHC090S1A	BHC090S2A
BAC120M1A	BAC120M2A	BHC120M1A	BHC120M2A
BAC120S1A	BAC120S2A	BHC120S1A	BHC120S2A
BAC150M1A	BAC150M2A	-	-
BAC150S1A	BAC150S2A	-	-
BAC180M1A	BAC180H2A	BHC180M1A	BHC180H2A
-	BAC180L2A	-	BHC180L2A
BAC180S1A	BAC180S2A	BHC180S1A	BHC180S2A
BAC240H1A	BAC240H2A	-	-
BAC240L1A	BAC240L2A	-	-
BAC240S1A	BAC240S2A	-	-
BAC245H1A	BAC245H2A	-	-
BAC245L1A	BAC245L2A	-	-
BAC245S1A	BAC245S2A	-	-

* Models have standard motor and standard static drive.

PHYSICAL DATA: BAC SERIES - ENGLISH

UNIT BAC	075	090	120	150	180	240 / 245
NOMINAL CAPACITY (Tons)	6	7 ¹ / ₂	10	12 ¹ / ₂	15	20
OPERATING WEIGHT (lb)						
Base Unit with TXV	381	385	405	670	685	690 / 730
Plenum	175	175	175	225	225	225
FANS						
Qty...Diam. (in.)	1...15	1...15	1...15	2...15	2...15	2...15
Nominal Airflow (cfm)	2400	3000	4000	5000	6000	8000
Airflow Range (cfm)	1800-3000	2250-3750	3000-5000	3750-6250	4500-7500	6000-10,000
Nominal Motor Hp (Standard Motor) *						
208/230-3-60 and 460-3-60	2.4	2.4	2.4	2.9	3.7	5.0
575-3-60	1.0	2.0	2.0	3.0	3.0	5.0
Motor Speed (rpm)						
208/230-3-60 and 460-3-60	1725	1725	1725	1725	1725	1745
575-3-60	1725	1725	1725	1725	1725	1745
REFRIGERANT R-22						
Operating charge (lb) (approx per circuit) †	3.0	3.0	1.5/1.5	2.0/2.0	2.5/2.5	3.5/3.5
DIRECT-EXPANSION COIL Enhanced Copper Tubes, Aluminum Sine-Wave Fins						
Max Working Pressure (psig)	435					
Face Area (sq ft)	6.67	8.33	10.01	3.25	17.67	19.88
No. of Splits	1	1	2	2	2	2
Split Type...Percentage	—	—	Face...50/50			
No. of Circuits per Split	12	15	9	9	12	13 / 18
Rows...Fins/in.	3...15	3...15	3...17	3...15	3...15	3...17 / 4...17
STEAM COIL						
Max Working Pressure (psig at 400 F)	175					
Total Face Area (sq ft)	6.67	6.67	6.67	13.33	13.33	13.33
Rows...Fins/in.	1...9	1...9	1...9	1...10	1...10	1...10
HOT WATER COIL						
Max Working Pressure (psig)	150					
Total Face Area (sq ft)	6.67	6.67	6.67	13.33	13.33	13.33
Rows...Fins/in.	2...8.5	2...8.5	2...8.5	2...8.5	2...8.5	2...8.5
Water Volume						
(gal)	8.3			13.9		
(ft ³)	1.1			1.85		
PIPING CONNECTIONS						
Quantity...Size (in.)						
DX Coil — Suction (ODF)	1...1 ¹ / ₈	1...1 ¹ / ₈	2...1 ¹ / ₈	2...1 ¹ / ₈	2...1 ¹ / ₈	2...1 ¹ / ₈
DX Coil — Liquid Refrigerant (ODF)	1... ⁵ / ₈		2... ⁵ / ₈			
Steam Coil, In (MPT)	1...2 ¹ / ₂		1...2 ¹ / ₂			
Steam Coil, Out (MPT)	1...1 ¹ / ₂		1...1 ¹ / ₂			
Hot Water Coil, In (MPT)	1...1 ¹ / ₂		1...1 ¹ / ₂	1...2		
Hot Water Coil, Out (MPT)	1...1 ¹ / ₂		1...1 ¹ / ₂	1...2		
Condensate (PVC)	1...1 ¹ / ₄ ODM/1 IDF					
FILTERS Throwaway — Factory Supplied						
Quantity...Size (in.)	4...16 x 24 x 2			4...16 x 20 x 2 4...16 x 24 x 2		
Access Location	Right or Left Side					

* Refer to alternate Fan Motor Data Table, pages 33 and 34, for alternate motor data.

LEGEND

DX - Direct Expansion

TXV - Thermostatic Expansion Valve

†Units are shipped without refrigerant charge.

PHYSICAL DATA: BAC SERIES - SI

UNIT BAC	075	090	120	150	180	240 / 245
NOMINAL CAPACITY (kW)	21	26	35	43	52	70
OPERATING WEIGHT (kg)						
Base Unit with TXV	173	175	184	304	311	313 / 331
Plenum	80	80	80	102	102	102
FANS						
Qty...Diam. (mm)	1...381	1...381	1...381	2...381	2...381	2...381
Nominal Airflow (L/s)	1133	1604	1888	2360	2831	3775
Airflow Range (L/s)	850-1416	1203-2006	1416-2360	1770-2949	2124-3539	2831-4719
Nominal Motor kW (Standard Motor) *						
208/230-3-60 and 460-3-60	1.79	1.79	1.79	2.16	2.76	3.73
575-3-60	0.75	1.49	1.49	2.24	2.24	3.73
Motor Speed (r/s)						
208/230-3-60 and 460-3-60	28.8	28.8	28.8	28.8	28.8	29.1
575-3-60	28.8	28.8	28.8	28.8	28.8	29.1
REFRIGERANT R-22						
Operating charge (kg) (approx per circuit)†	1.36	1.36	0.68/0.68	0.90/0.90	1.13/1.13	1.59/1.59
DIRECT-EXPANSION COIL Enhanced Copper Tubes, Aluminum Sine-Wave Fins						
Max Working Pressure (kPag)	2999					
Face Area (sq m)	0.62	0.77	0.93	0.93	1.64	1.85
No. of Splits	1	1	2	2	2	2
No. of Circuits per Split	12	15	9	9	12	13 / 18
Split Type...Percentage	—		Face...50/50			
Rows...Fins/m	3...591	3...591	3...670	3...591	3...591	3.670 / 4.670
STEAM COIL						
Max Working Pressure (kPag at 204.4 C)	1207					
Total Face Area (sq m)	0.62	0.62	0.62	1.24	1.24	1.24
Rows...Fins/m	1...355	1...355	1...355	1...394	1...394	1...394
HOT WATER COIL						
Max Working Pressure (kPag)	1034					
Total Face Area (sq m)	0.62	0.62	0.62	1.24	1.24	1.24
Rows...Fins/m	2...335	2...335	2...335	2...335	2...335	2...335
Water Volume						
(L)	31.4			52.6		
(m ³)	0.031			0.052		
PIPING CONNECTIONS**						
Quantity...Size (in.)						
DX Coil — Suction (ODF)	1...1 ¹ / ₈	1...1 ¹ / ₈	2...1 ¹ / ₈	2...1 ¹ / ₈	2...1 ¹ / ₈	2...1 ¹ / ₈
DX Coil — Liquid Refrigerant (ODF)	1...5 ⁵ / ₈		2...5 ⁵ / ₈			
Steam Coil, In (MPT)	1...2 ¹ / ₂		1...2 ¹ / ₂			
Steam Coil, Out (MPT)	1...1 ¹ / ₂		1...1 ¹ / ₂			
Hot Water Coil, In (MPT)	1...1 ¹ / ₂		1...1 ¹ / ₂	1...2		
Hot Water Coil, Out (MPT)	1...1 ¹ / ₂		1...1 ¹ / ₂	1...2		
Condensate (PVC)	1...1 ¹ / ₄ ODM/1 IDF					
FILTERS Throwaway — Factory Supplied						
Quantity...Size	4...406 x 610 x 51			4...406 x 508 x 51 4...406 x 610 x 51		
Access Location	Right or Left Side					

* Refer to alternate Fan Motor Data Table, pages 33 and 34, for alternate motor data.
 LEGEND - DX - Direct Expansion, TXV - Thermostatic Expansion Valve
 †Units are shipped without refrigerant charge.
 **All piping sizes are OD inches; equivalent sizes in millimeters follow:

in.	mm	in.	mm
5 ⁵ / ₈	15.9	1 ¹ / ₂	38.7
1	25.4	2	50.8
1 ¹ / ₈	28.6	2 ¹ / ₈	54.0
1 ¹ / ₄	31.8	2 ¹ / ₂	63.5
1 ³ / ₈	34.9		

PHYSICAL DATA: BHC SERIES - ENGLISH			
UNIT BHC	090	120	180
NOMINAL CAPACITY (Tons)	7 ¹ / ₂	10	15
OPERATING WEIGHT (lb)			
Base Unit with TXV	385	427	713
Plenum	175	175	225
FANS			
Qty...Diam. (in.)	1...15	1...15	2...15
Nominal Airflow (cfm)	3000	4000	6000
Airflow Range (cfm)	2250-3750	3000-5000	4500-7500
Nominal Motor Hp (Standard Motor) *			
208/230-3-60 and 460-3-60	2.4	2.4	3.7
575-3-60	2.0	2.0	3.0
Motor Speed (rpm)			
208/230-3-60 and 460-3-60	1725	1725	1725
575-3-60	1725	1725	1725
REFRIGERANT R-22			
Operating charge (lb) (approx per circuit)†	3.0	2.0/2.0	3.0/3.0
DIRECT-EXPANSION COIL Enhanced Copper Tubes, Aluminum Sine-Wave Fins			
Max Working Pressure (psig)	435		
Face Area (sq ft)	8.33	10.01	7.67
No. of Splits	1	2	2
Split Type...Percentage	—	Face...50/50	
No. of Circuits per Split	15	9	16
Rows...Fins/in.	3...15	4...15	4...15
STEAM COIL			
Max Working Pressure (psig at 400 F)	175		
Total Face Area (sq ft)	6.67	6.67	13.33
Rows...Fins/in.	1...9	1...9	1...10
HOT WATER COIL			
Max Working Pressure (psig)	150		
Total Face Area (sq ft)	6.67	6.67	13.33
Rows...Fins/in.	2...8.5	2...8.5	2...8.5
Water Volume			
(gal)	8.3		13.9
(ft ³)	1.1		1.85
PIPING CONNECTIONS			
Quantity...Size (in.)			
DX Coil — Suction (ODF)	1...1 ¹ / ₈	2...1 ¹ / ₈	2...1 ¹ / ₈
DX Coil — Liquid Refrigerant (ODF)	1... ⁵ / ₈	2... ⁵ / ₈	2... ⁵ / ₈
Steam Coil, In (MPT)	1...2 ¹ / ₂	1...2 ¹ / ₂	
Steam Coil, Out (MPT)	1...1 ¹ / ₂	1...1 ¹ / ₂	
Hot Water Coil, In (MPT)	1...1 ¹ / ₂	1...1 ¹ / ₂	1...2
Hot Water Coil, Out (MPT)	1...1 ¹ / ₂	1...1 ¹ / ₂	1...2
Condensate (PVC)	1...1 ¹ / ₄ ODM/1 IDF		
FILTERS Throwaway — Factory Supplied			
Quantity...Size (in.)	4...16 x 24 x 2		4...16 x 20 x 2 4...16 x 24 x 2
Access Location	Right or Left Side		

* Refer to alternate Fan Motor Data Table, pages 33 and 34, for alternate motor data.

LEGEND - DX - Direct Expansion, TXV - Thermostatic Expansion Valve

†Units are shipped without refrigerant charge.

PHYSICAL DATA: BHC SERIES - SI			
UNIT BHC	090	120	180
NOMINAL CAPACITY (kW)	26	35	52
OPERATING WEIGHT (kg)			
Base Unit with TXV	175	194	323
Plenum	80	80	102
FANS			
Qty...Diam. (mm)	1...381	1...381	2...381
Nominal Airflow (L/s)	1604	1888	2831
Airflow Range (L/s)	1203-2006	1416-2360	2124-3539
Nominal Motor kW (Standard Motor) *			
208/230-3-60 and 460-3-60	1.79	1.79	2.76
575-3-60	1.49	1.49	2.24
Motor Speed (r/s)			
208/230-3-60 and 460-3-60	28.8	28.8	28.8
575-3-60	28.8	28.8	28.8
REFRIGERANT		R-22	
Operating charge (kg) (approx per circuit)†	1.36	0.91/0.91	1.36/1.36
DIRECT-EXPANSION COIL			
Max Working Pressure (kPag)	2999		
Face Area (sq m)	0.77	0.93	1.64
No. of Splits	1	2	2
No. of Circuits per Split	15	9	16
Split Type...Percentage	—	Face...50/50	
Rows...Fins/m	3...591	4...591	4...591
STEAM COIL			
Max Working Pressure (kPag at 204.4 C)	1207		
Total Face Area (sq m)	0.62	0.62	1.24
Rows...Fins/m	1...355	1...355	1...394
HOT WATER COIL			
Max Working Pressure (kPag)	1034		
Total Face Area (sq m)	0.62	0.62	1.24
Rows...Fins/m	2...335	2...335	2...335
Water Volume			
(L)	31.4		52.6
(m³)	0.031		0.052
PIPING CONNECTIONS**			
Quantity...Size (in.)			
DX Coil — Suction (ODF)	1...1 ¹ / ₈	2...1 ¹ / ₈	2...1 ¹ / ₈
DX Coil — Liquid Refrigerant (ODF)	1... ⁵ / ₈	2... ⁵ / ₈	2... ⁵ / ₈
Steam Coil, In (MPT)	1...2 ¹ / ₂	1...2 ¹ / ₂	
Steam Coil, Out (MPT)	1...1 ¹ / ₂	1...1 ¹ / ₂	
Hot Water Coil, In (MPT)	1...1 ¹ / ₂	1...1 ¹ / ₂	1...2
Hot Water Coil, Out (MPT)	1...1 ¹ / ₂	1...1 ¹ / ₂	1...2
Condensate (PVC)	1...1 ¹ / ₄ ODM/1 IDF		
FILTERS			
Throwaway — Factory Supplied			
Quantity...Size	4...406 x 610 x 51		4...406 x 508 x 51 4...406 x 610 x 51
Access Location	Right or Left Side		

* Refer to alternate Fan Motor Data Table, pages 33 and 34, for alternate motor data.

LEGEND - DX - Direct Expansion, TXV - Thermostatic Expansion Valve

†Units are shipped without refrigerant charge.

**All piping sizes are OD inches; equivalent sizes in millimeters follow:

in.	mm
⁵ / ₈	15.9
1	25.4
1 ¹ / ₈	28.6

1 ¹ / ₄	31.8
1 ³ / ₈	34.9
1 ¹ / ₂	38.7
2	50.8
2 ¹ / ₈	54.0
2 ¹ / ₂	63.5

OPTIONS AND ACCESSORIES

Factory-installed options

Air handlers available with standard motor and medium static drive or choose alternate motor and high static drive package.

Field-installed accessories

Two-row hot water coils have copper tubes mechanically bonded to aluminum plate fins and non-ferrous headers.

One-row steam coil has copper tubes and aluminum fins. The Inner Distributing Tube (IDT) design provides uniform temperatures across the coil face. The steam coil has a broad operating pressure range; up to 175 psig (1207 kPag) at 400 F (204.4 C) and up to 300 psig (2069 kPag) at 300 F (148.9 C). The IDT steam coils are especially suited to applications where sub-freezing air enters the unit.

Electric resistance heat coils have an open-wire design and are mounted in a rigid frame. Safety cutouts for high temperature conditions are standard. Terminal block for single-point power connection is included.

Economizer (enthalpy controlled) provides ventilation air and “free” cooling if outside ambient temperature and humidity are suitable. Can also be used with CO₂ sensors to help meet indoor air quality requirements.

Discharge plenum directs the air discharge directly into the occupied space; integral horizontal and vertical louvers enable redirection of airflow. Field assembly required.

Return-air grille provides a protective barrier over the return-air opening and gives a finished appearance to units installed in the occupied space.

Subbase provides a stable, raised platform and room for condensate drain trap connection for vertical floor-mounted units.

Overhead suspension package includes necessary brackets to support units in horizontal ceiling installations.

Condensate drain trap includes an overflow shutoff switch that can be wired to turn off the unit if the trap becomes plugged. Kit also includes a wire harness that can be connected to an alarm if desired. The transparent trap is designed for easy service and maintenance.

ACCESSORY MODEL NUMBERS ARE SHOWN ON PAGE 38.

OPTIONS AND ACCESSORIES

BAC WITH DISCHARGE PLENUM, RETURN-AIR GRILLE AND SUBBASE

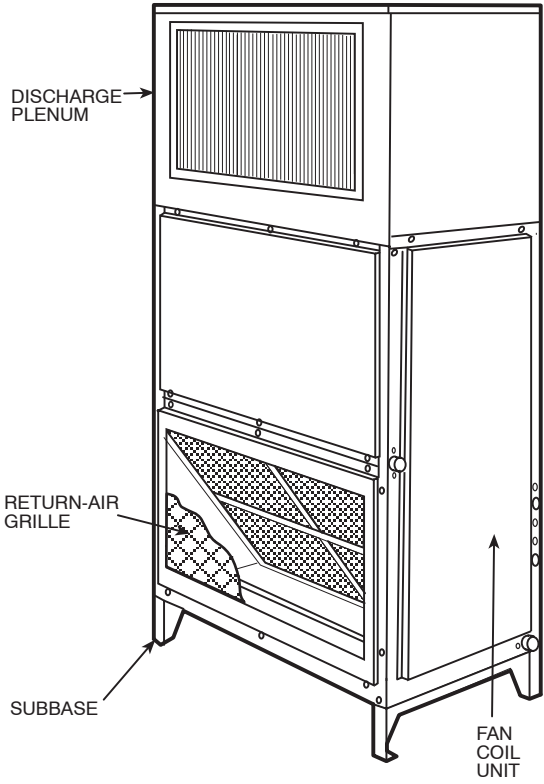

BAC WITH HOT WATER OR STEAM COIL

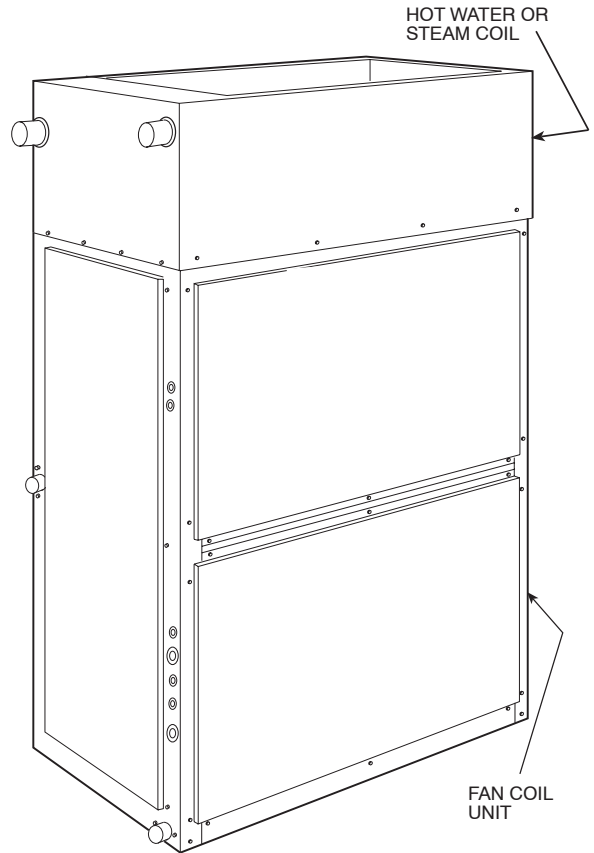

BAC WITH ECONOMIZER

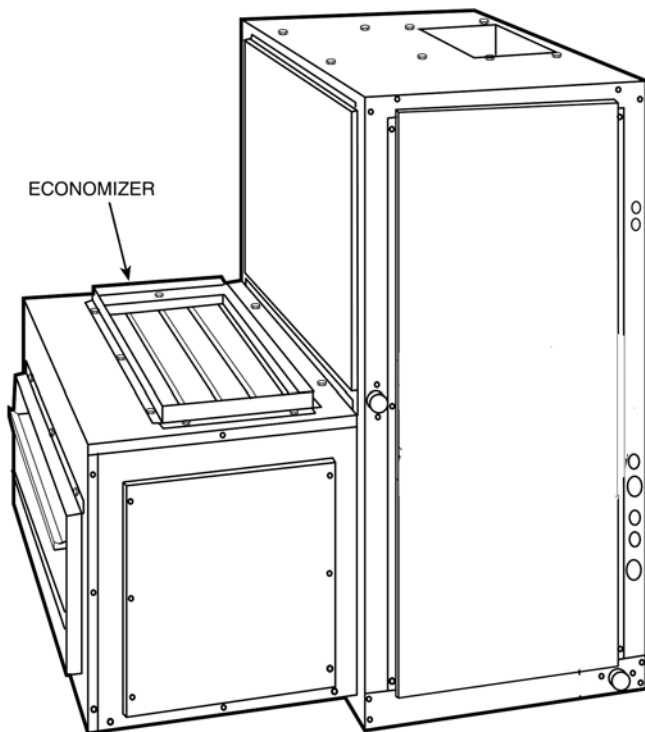

BAC WITH CONDENSATE TRAP

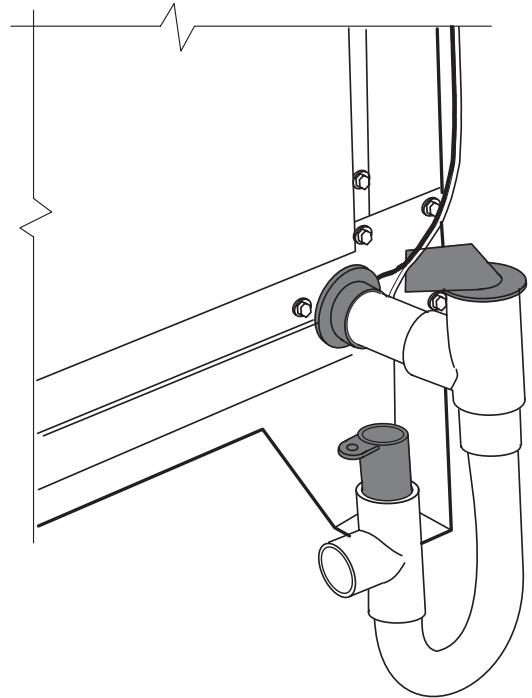

DIMENSIONS

**BAC075-120
BHC090-120**

UNIT	Unit Weight lb (kg)
BAC075	381 (173)
BAC090	385 (175)
BAC120	405 (184)
BHC090	385 (175)
BHC120	427 (194)

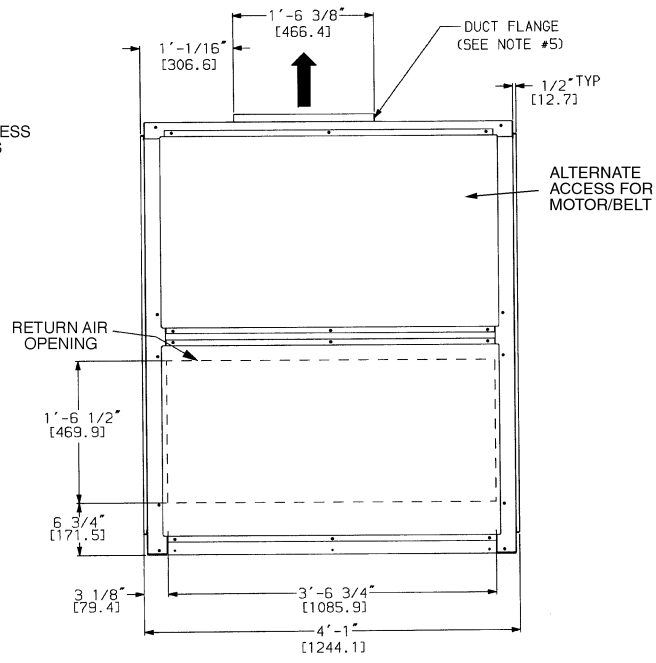
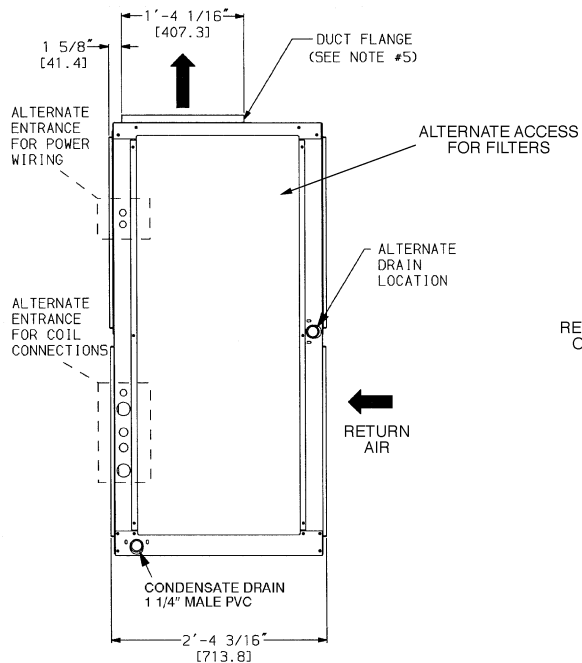
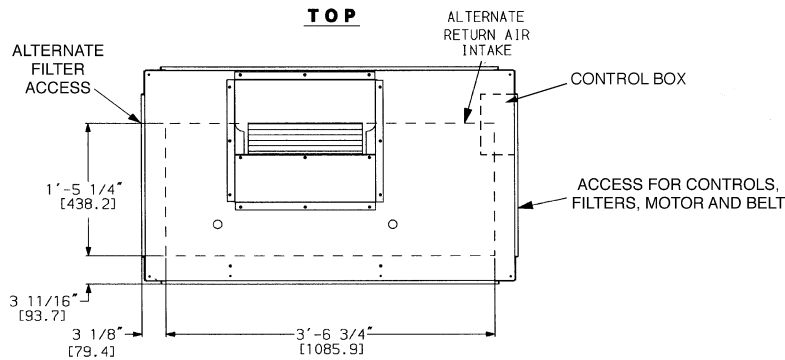

LEFT SIDE

FRONT

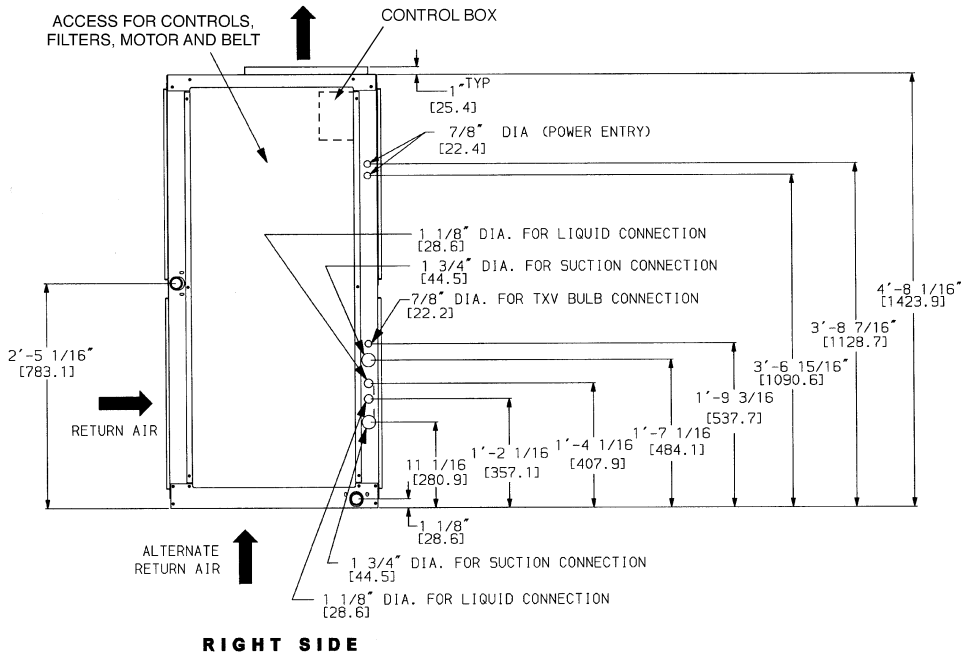

RIGHT SIDE

NOTES:

1. Dimensions in [] are in millimeters.
2. ➔ Direction of airflow.
3. Recommended clearance:
 - Rear: 3" (76.2 mm) (2'-6" [762 mm] with electric heat accessory)
 - Front: 2'-6" (762 mm)
 - Right side: 2'-6" (762 mm)
 - Left Side: 2'-6" (762 mm)
 - Local codes or jurisdiction may prevail.
4. Liquid piping not supplied.
5. Duct flange is factory supplied and field installed.

DIMENSIONS

**BAC150-245
BHC180**

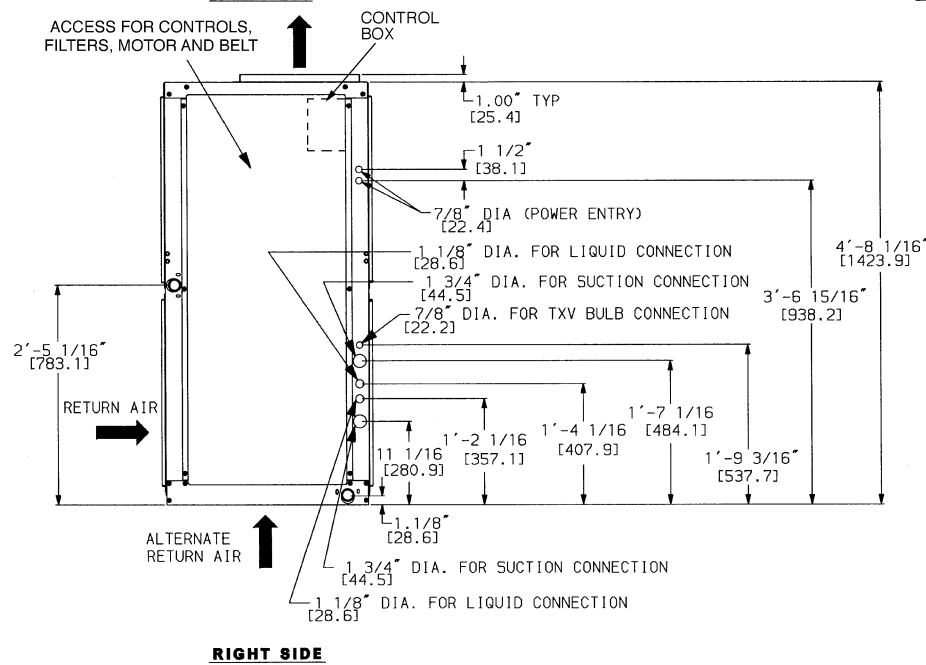
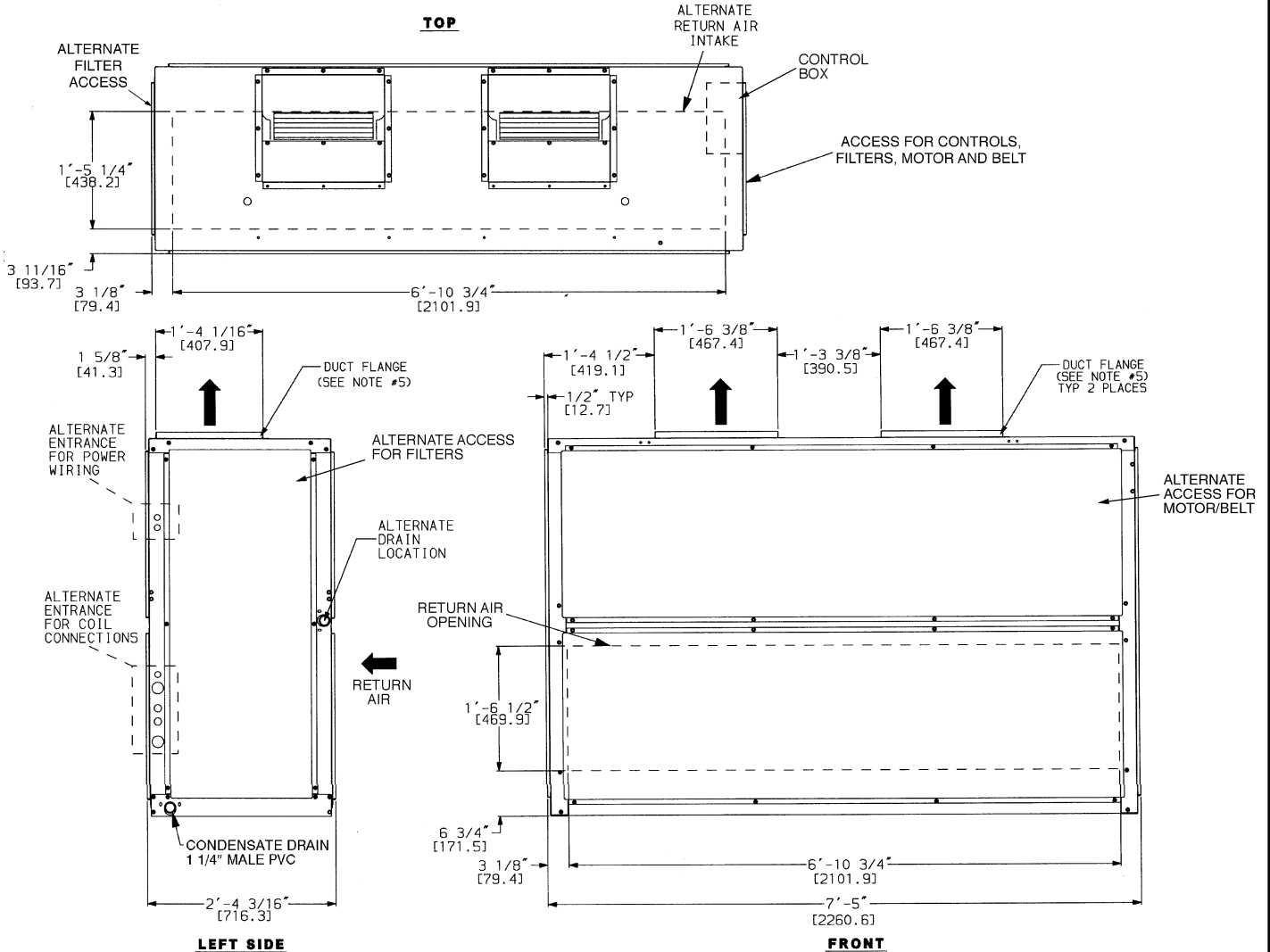

NOTES:

1. Dimensions in [] are in millimeters.
2. ➡ Direction of airflow.
3. Recommended clearance:
 - Rear: 3" (76.2 mm) (2'-6" [762 mm] with electric heat accessory)
 - Front: 2'-6" (762 mm)
 - Right side: 2'-6" (762 mm)
 - Left Side: 2'-6" (762 mm)
 - Local codes or jurisdiction may prevail.
4. Liquid piping not supplied.
5. Duct flange is factory supplied and field installed.

UNIT	Unit Weight lb (kg)
BAC150	670 (304)
BAC180	685 (311)
BAC240	690 (313)
BHC180	713 (323)

OVERHEAD SUSPENSION ACCESSORY

UNIT SIZES 075-120

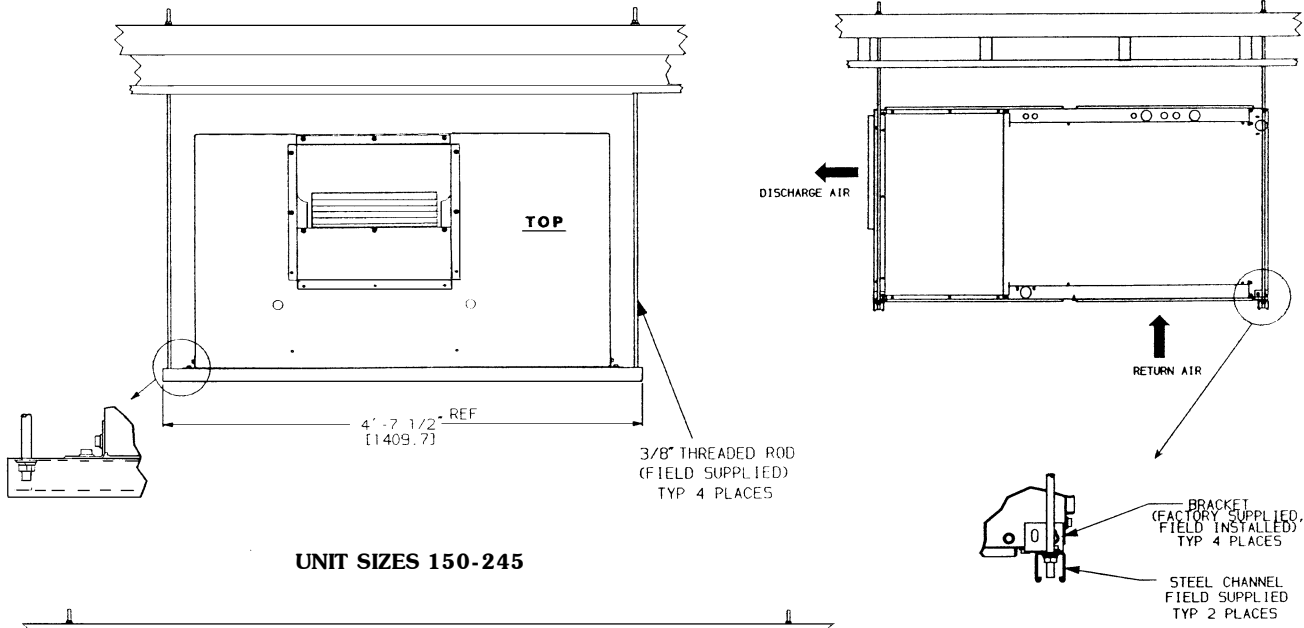

UNIT SIZES 150-245

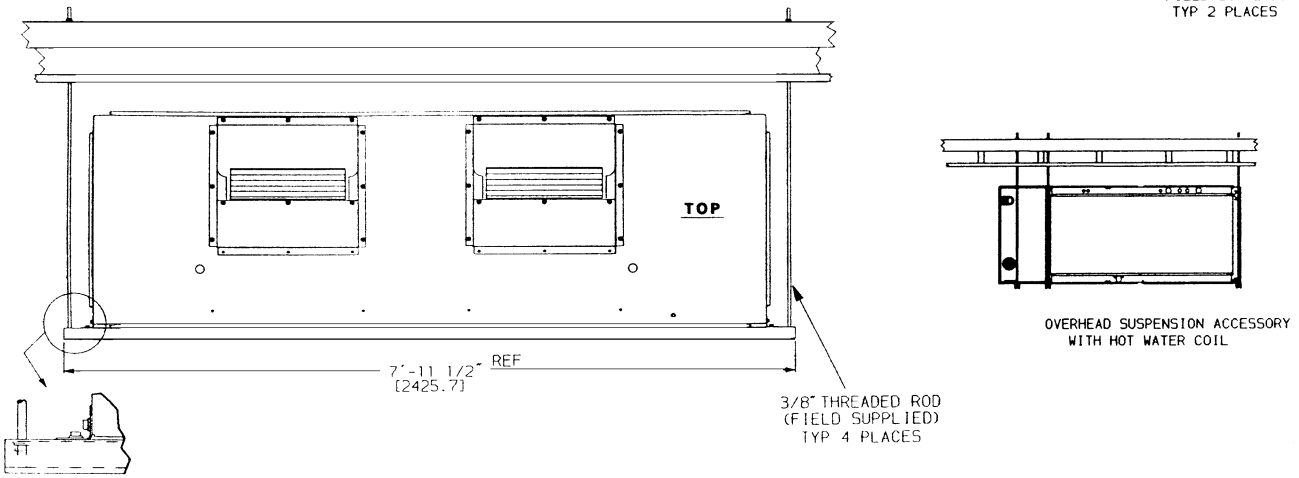

NOTE: Dimensions in [] are millimeters.

PLENUM, RETURN-AIR GRILLE, AND SUBBASE ACCESSORIES

UNIT SIZES 075-120

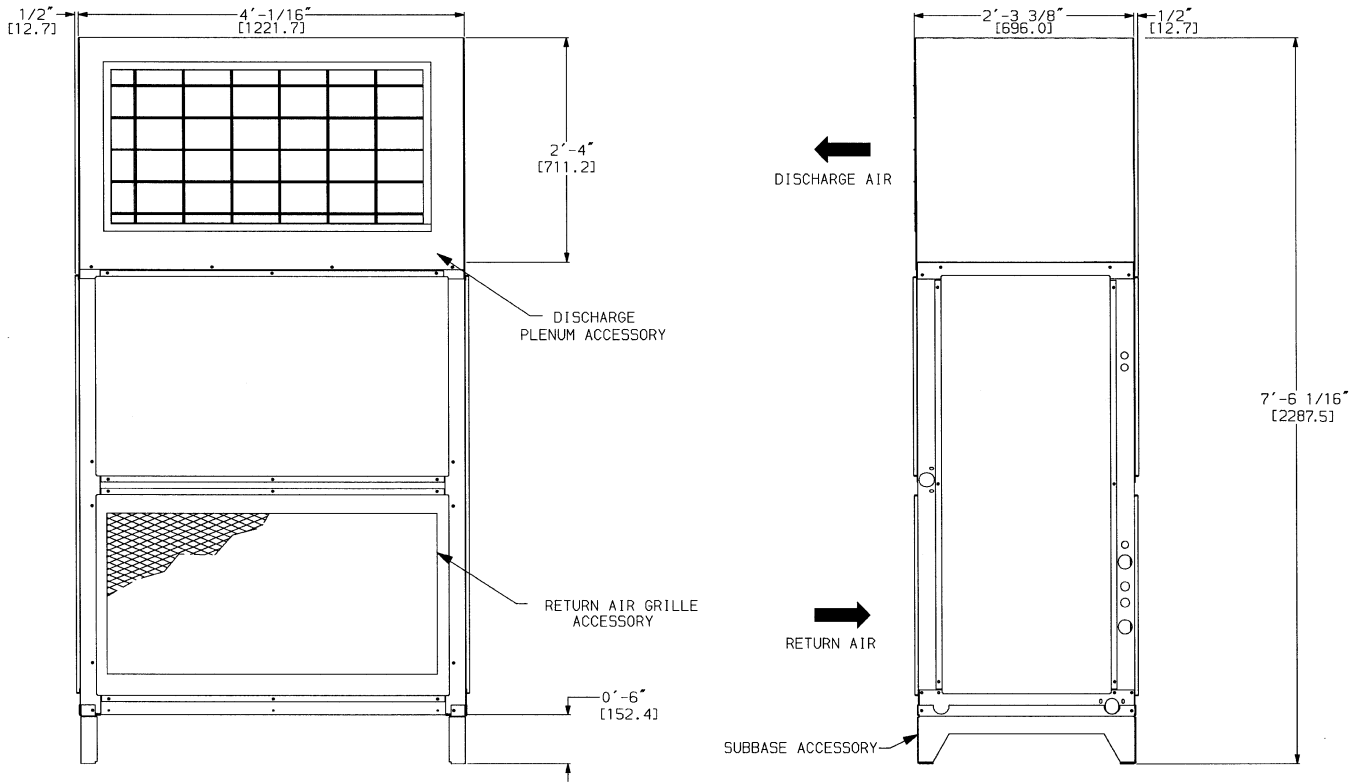

UNIT SIZES 150-245

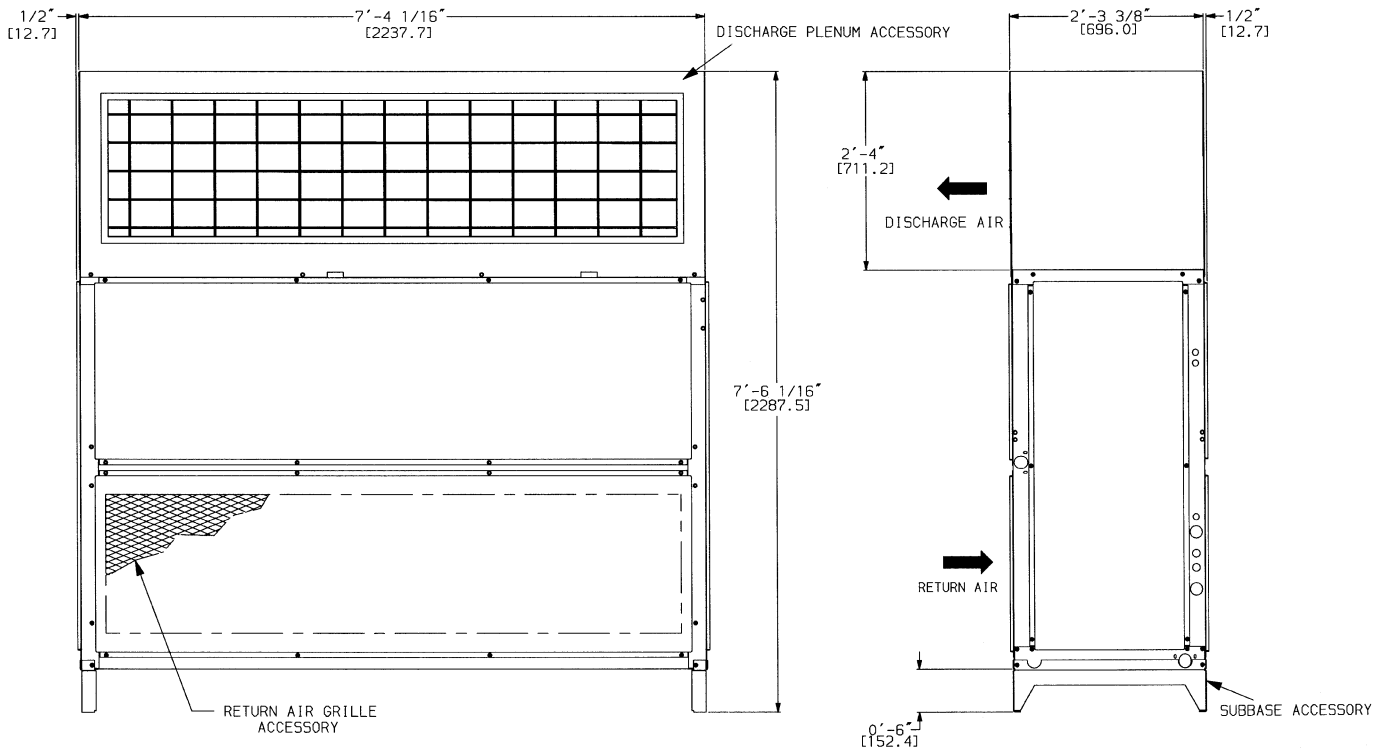

NOTE: Dimensions in [] are millimeters.

HOT WATER AND STEAM COIL ACCESSORIES

UNIT SIZES 075-120

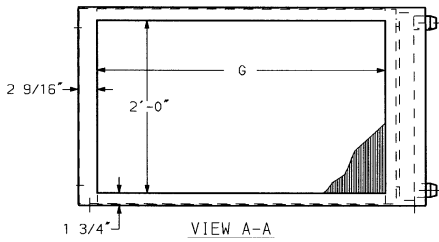
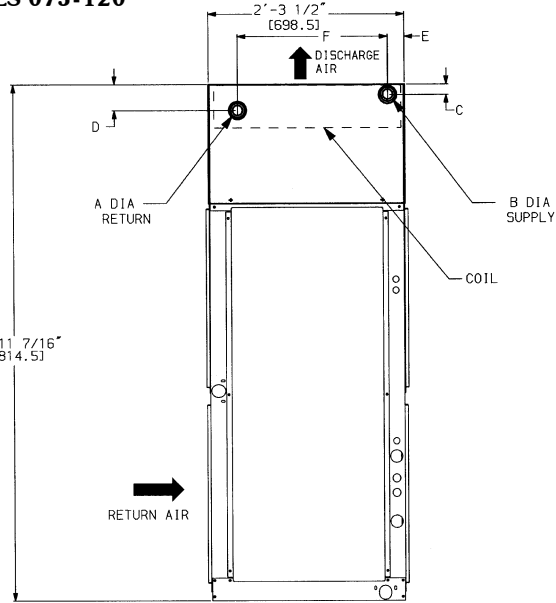
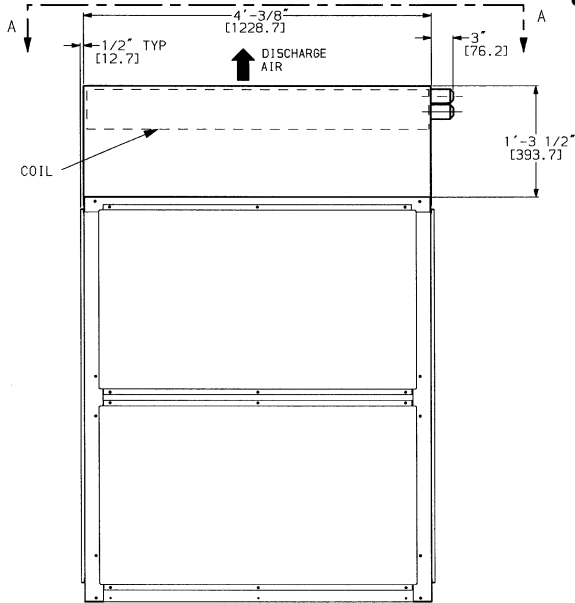

Dimension	Hot Water Coil	Steam Coil
A	1-1/2" MPT (38.1)	1-1/2" MPT (38.1)
B	1-1/2" MPT (38.1)	2-1/2" MPT (63.5)
C	2-3/8" (60.3)	3-1/8" (79.4)
D	4-7/8" (123.8)	3-1/8" (79.4)
E	2-1/8" (54.0)	4-9/16" (115.8)
F	1'-11-1/4" (590.6)	1'-9" (584.2)
G	3'-4" (1016.0)	3'-4" (1016.0)

UNIT SIZES 150-245

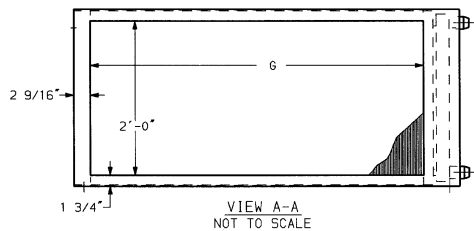
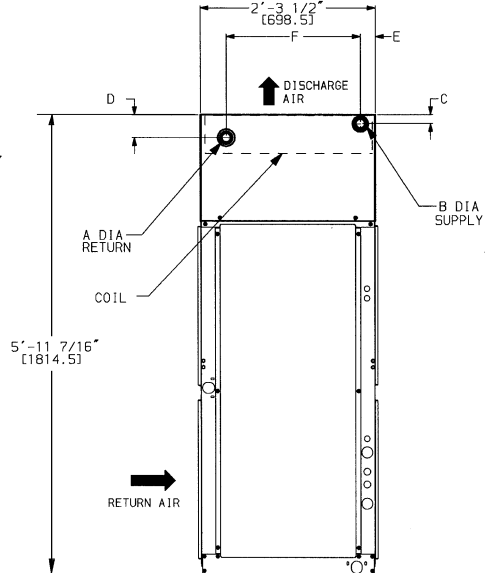
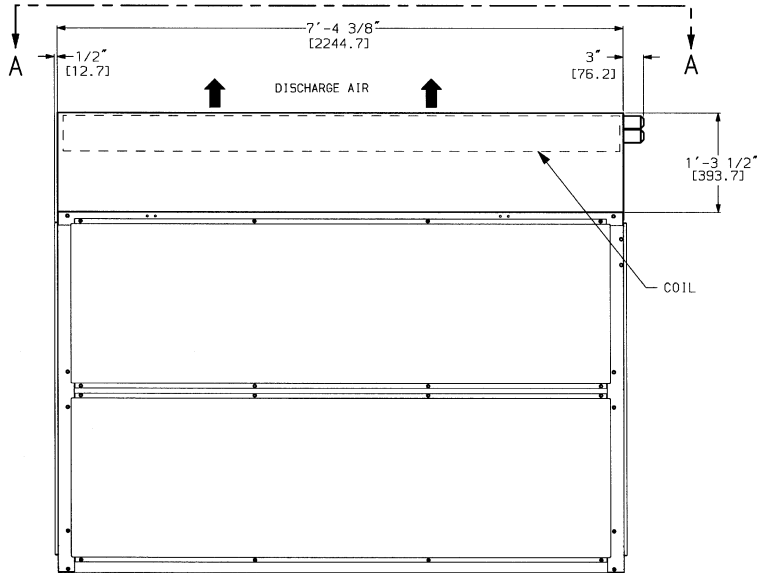

Dimension	Hot Water Coil	Steam Coil
A	1-1/2" MPT (38.1)	1-1/2" MPT (38.1)
B	1-1/2" MPT (38.1)	2-1/2" MPT (63.5)
C	2-3/8" (60.3)	3-1/8" (79.4)
D	4-7/8" (123.8)	3-1/8" (79.4)
E	2-1/8" (54.0)	4-9/16" (115.8)
F	1'-11-1/4" (590.6)	1'-9" (584.2)
G	6'-8" (2032.0)	6'-8" (2032.0)

NOTE: Dimensions in [] are millimeters.

ECONOMIZER ACCESSORY

UNIT SIZES 075-120

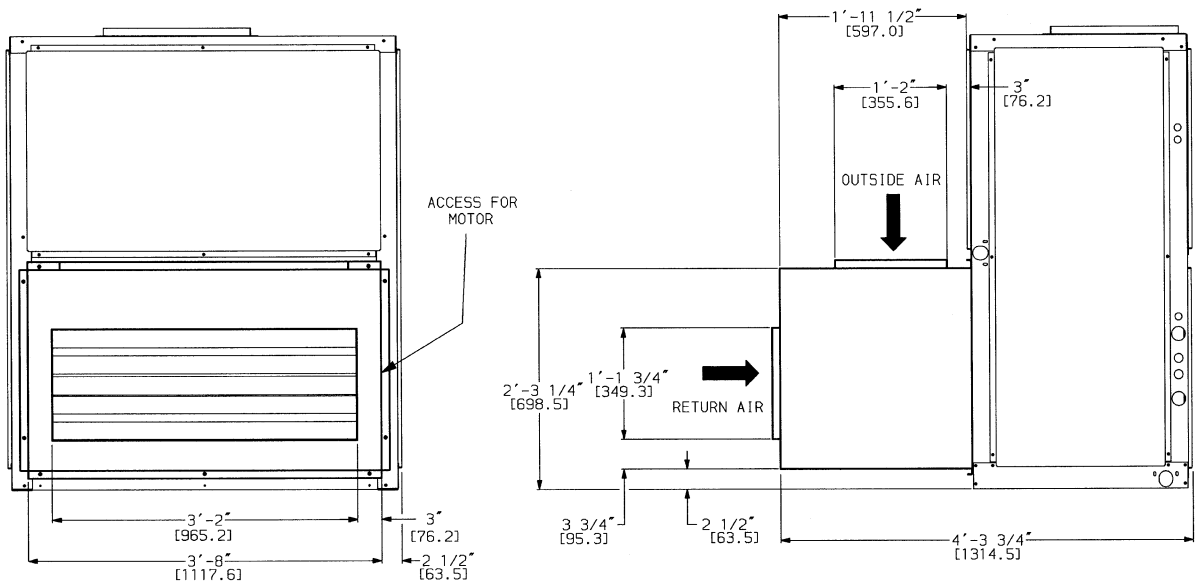

UNIT SIZES 150-245

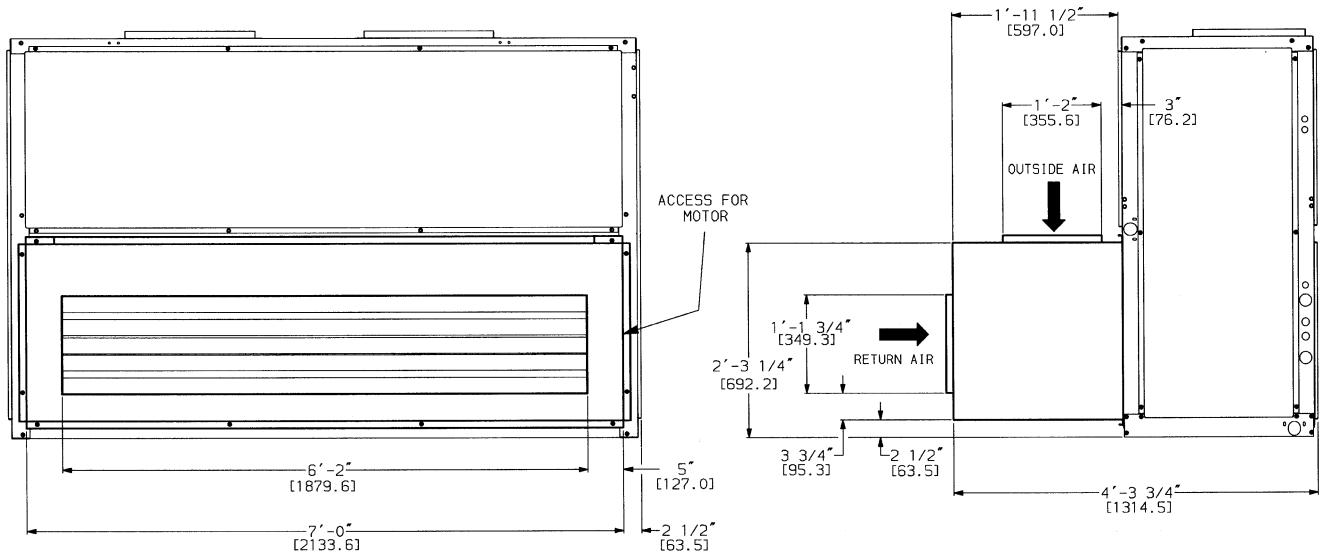

NOTE:

1. For horizontal unit applications, economizer can be attached to end of unit opposite duct connections.
2. Dimensions in [] are millimeters.

DIMENSIONS

ELECTRIC HEAT ACCESSORY UNIT SIZES 075-120

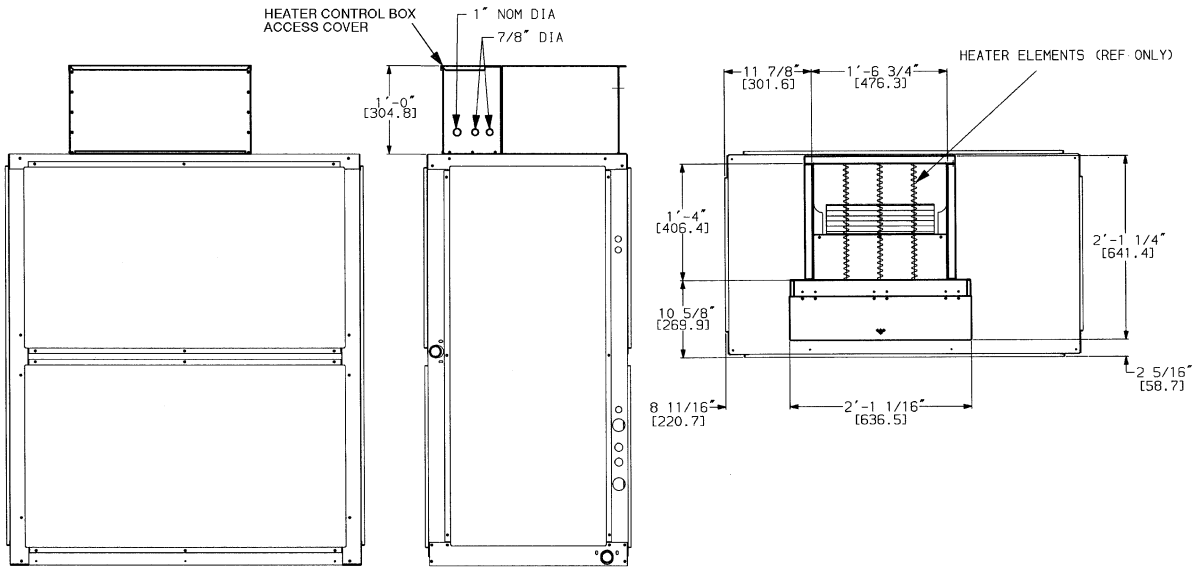

UNIT SIZES 150-245

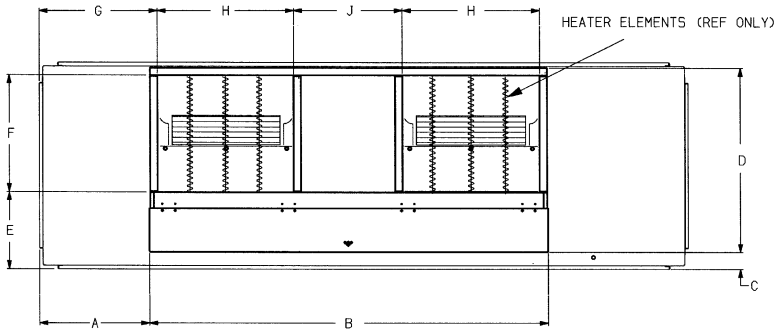
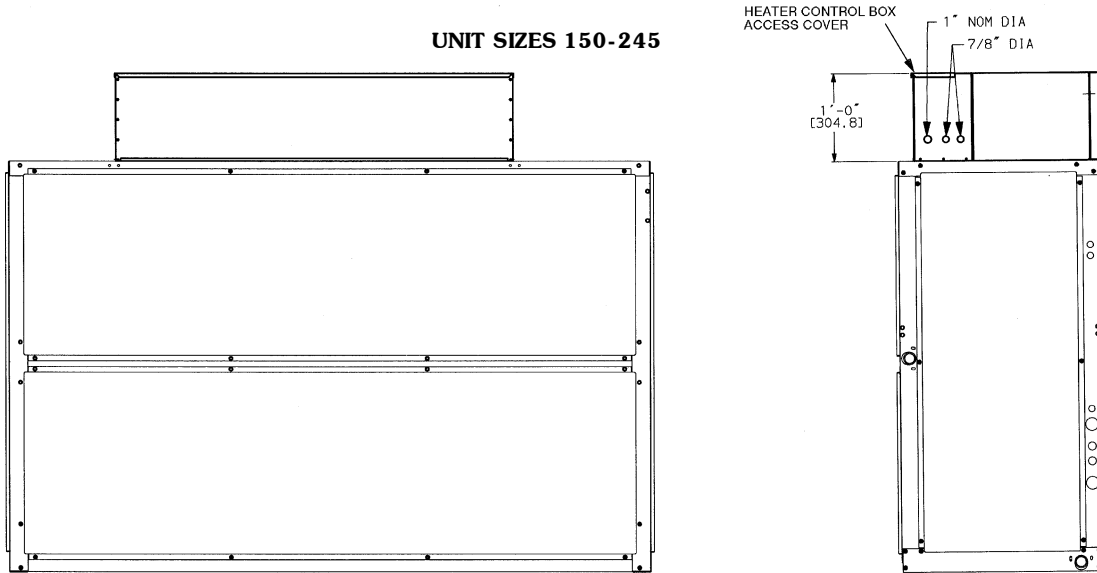

NOTE: Dimensions in [] are millimeters.

Unit Size	A	B	C	D	E	F	G	H	J
075-240	1' 3-1/4" (387.4)	4' 6-3/8" (1381.1)	2-5/16" (58.7)	2' 1-1/4" (641.4)	10-5/8" (269.9)	1' 4" (406.4)	1' 4-5/16" (414.3)	1' 6-3/4" (476.3)	1-7/8" (327.0)

PERFORMANCE DATA: BAC SERIES, COOLING CAPACITIES — ENGLISH

UNIT BAC	EVAPORATOR AIR		COIL REFRIGERANT TEMP (F)									
	Airflow (Cfm) BF	Ewb (F)	30		35		40		45		50	
			TC	SHC	TC	SHC	TC	SHC	TC	SHC	TC	SHC
075	1,800 0.06	72	116	55	104	50	93	46	79	40	64	35
		67	96	61	85	56	74	50	61	45	47	40
		62	80	66	69	61	57	55	46	46	39	39
	2,400 0.10	72	135	65	121	60	108	54	92	48	75	42
		67	112	73	99	68	86	62	71	56	55	49
		62	94	81	81	75	67	67	56	56	47	47
	3,000 0.12	72	150	73	135	68	120	62	102	56	83	49
		67	125	85	112	78	96	71	80	65	61	57
		62	105	95	90	86	75	75	64	64	54	54
090	2,250 0.06	72	144	69	130	63	116	57	99	50	80	43
		67	120	76	106	70	92	63	76	56	59	50
		62	100	83	87	76	71	69	57	57	49	49
	3,000 0.10	72	169	81	151	75	135	68	114	61	94	53
		67	140	92	124	85	108	77	89	69	69	62
		62	118	101	102	94	84	84	70	70	59	59
	3,750 0.12	72	187	92	168	85	150	78	127	70	104	61
		67	157	106	140	97	120	89	100	81	77	72
		62	132	118	112	108	94	94	80	80	68	68
120	3,000 0.05	72	193	92	174	81	154	76	132	67	108	58
		67	161	102	143	93	123	85	102	76	79	67
		62	134	111	116	102	96	93	78	78	66	66
	4,000 0.07	72	223	108	201	99	179	91	153	81	125	71
		67	186	122	166	113	143	104	119	93	92	82
		62	157	136	136	126	113	113	95	95	80	80
	5,000 0.12	72	246	122	222	112	198	103	169	93	138	81
		67	207	140	185	131	159	120	132	109	102	97
		62	175	159	149	145	126	126	109	109	92	92
150	3,750 0.06	72	223	107	204	99	183	91	157	81	127	70
		67	188	121	169	112	144	102	118	90	94	81
		62	154	133	136	123	114	111	94	94	80	80
	5,000 0.08	72	259	126	234	117	210	108	180	97	145	85
		67	220	146	194	136	166	124	138	112	110	100
		62	178	163	156	150	134	134	114	114	97	97
	6,250 0.10	72	284	142	257	132	230	122	198	111	160	98
		67	242	166	209	154	183	145	153	131	119	117
		62	197	188	172	172	150	150	130	130	111	111
180	4,500 0.03	72	282	134	254	123	228	112	194	100	162	89
		67	233	149	209	138	178	125	149	112	117	99
		62	192	163	169	151	141	138	116	116	98	98
	6,000 0.05	72	320	156	293	145	263	134	223	119	179	104
		67	276	181	243	167	207	153	174	137	137	123
		62	225	200	198	185	167	167	140	140	119	119
	7,500 0.08	72	358	177	319	163	290	152	248	137	197	120
		67	305	208	263	192	229	178	193	160	153	144
		62	512	322	182	151	88	188	161	161	136	136

See Legend on following page.

PERFORMANCE DATA: BAC SERIES, COOLING CAPACITIES — ENGLISH (Cont.)

UNIT BAC	EVAPORATOR AIR		COIL REFRIGERANT TEMP (F)									
	Airflow (Cfm) BF	Ewb (F)	30		35		40		45		50	
			TC	SHC	TC	SHC	TC	SHC	TC	SHC	TC	SHC
240	6,000 0.03	72	365	174	330	161	296	147	254	131	206	114
		67	309	198	274	182	234	166	195	150	153	132
		62	250	216	221	200	186	182	155	155	132	132
	8,000 0.06	72	416	203	378	189	338	174	291	157	235	138
		67	354	237	305	217	269	202	224	183	179	163
		62	290	264	253	245	218	218	187	187	159	159
	10,000 0.07	72	454	228	413	213	373	198	319	179	259	160
		67	376	266	338	251	296	235	250	214	194	189
		62	316	303	279	278	244	244	213	213	182	182

UNIT BAC (High Capacity 4 row coil)	EVAPORATOR AIR		COIL REFRIGERANT TEMP (F)									
	Airflow (Cfm) BF	Ewb (F)	30		35		40		45		50	
			TC	SHC	TC	SHC	TC	SHC	TC	SHC	TC	SHC
245	6,000 0.04	72	408	197	372	180	331	162	272	141	232	123
		67	344	213	307	195	266	176	220	156	169	135
		62	286	227	248	208	207	188	164	164	139	139
	8,000 0.06	72	470	228	429	210	382	191	329	170	269	147
		67	399	253	357	233	309	212	256	189	197	166
		62	333	275	290	254	242	230	202	202	170	170
	10,000 0.08	72	516	253	471	235	421	215	363	192	297	168
		67	440	287	395	266	343	244	274	219	220	193
		62	369	317	322	294	271	266	232	232	196	196

LEGEND FOR PERFORMANCE TABLES - ENGLISH

BF - Bypass Factor
db - Dry-Bulb temp (F)
Ewb - Entering Wet-bulb Temp (F)
lwb - Leaving Wet-bulb Temp (F)
SHC - Sensible Heat Capacity (1000 Btuh)
TC - Total Capacity (1000 Btuh)

NOTES:

1. Direct interpolation is permissible. Do not extrapolate.
2. Evaporator fan heat not deducted from ratings.
3. Ratings based on approximately 15 F superheat leaving coil.
4. Dashes indicate coil loading limits are exceeded.
5. Formulas:

$$\text{Leaving db} = \text{entering db} - \frac{\text{sensible heat capacity (Btuh)}}{1.1 \times \text{cfm}}$$

$$\text{Leaving wb} = \text{wet-bulb temperature corresponding to enthalpy of air leaving coil (} h_{lwb} \text{)}$$

$$h_{lwb} = h_{ewb} - \frac{\text{total capacity (Btuh)}}{4.5 \times \text{cfm}}$$

where h_{ewb} = enthalpy of air entering coil

BYPASS FACTOR	ENTERING AIR DRY-BULB TEMP (F)					
	79	78	77	76	75	Under 75
	81	82	83	84	85	Over 85
	Correction Factor					
0.02	1.08	2.16	3.23	4.31	5.39	use formula shown below
0.05	1.05	2.09	3.14	4.18	5.23	
0.10	0.99	1.98	2.97	3.96	4.95	
0.15	0.94	1.87	2.81	3.74	4.68	
0.20	0.88	1.76	2.64	3.52	4.40	
0.25	0.83	1.65	2.48	3.30	4.13	
0.30	0.77	1.54	2.31	3.08	3.85	

Interpolation is permissible.
 Correction Factor = $1.1 \times (1 - \text{BF}) \times (\text{db} - 80)$

6. SHC is based on 80 F db temperature of air entering evaporator coil. Below 80 F db, subtract (corr factor x cfm) from SHC.

Above 80 F db, add (corr factor x cfm) to SHC. See italic type below.

PERFORMANCE DATA: BAC SERIES, COOLING CAPACITIES — SI

Unit BAC	EVAPORATOR AIR		COIL REFRIGERANT TEMP (C)													
	Airflow (L/s) BF	Ewb (C)	-1		0		2		4		6		8		10	
			TC	SHC	TC	SHC	TC	SHC	TC	SHC	TC	SHC	TC	SHC	TC	SHC
075	850 .06	22	33.73	16.27	32.43	15.75	29.83	14.69	27.23	13.64	24.62	12.60	22.02	11.57	19.40	10.57
		19	27.79	18.51	26.56	17.93	24.10	16.78	21.64	15.63	19.17	14.51	16.70	13.41	14.22	12.41
		16	22.73	21.09	21.58	20.29	19.27	18.70	16.95	16.95	14.62	14.62	12.28	12.28	9.93	9.93
	1150 .10	22	39.24	19.50	37.73	18.87	34.70	17.60	31.68	16.34	28.66	15.09	25.63	13.89	22.60	12.66
		19	32.37	22.21	30.93	21.58	28.06	20.32	25.18	19.08	22.30	17.86	19.41	16.79	16.51	15.64
		16	26.41	25.86	25.15	24.85	22.64	22.64	20.11	20.11	17.58	17.58	15.04	15.04	12.49	12.49
	1450 .12	22	43.88	21.85	42.16	21.22	38.71	19.97	35.26	18.72	31.82	17.50	28.37	16.33	24.92	23.63
		19	36.69	25.31	35.04	24.63	31.74	23.30	28.44	21.99	25.14	20.73	21.83	19.63	18.52	18.52
		16	29.14	29.14	27.82	27.82	25.19	25.19	22.55	22.55	19.91	19.91	17.26	17.26	14.61	14.61
090	1000 .06	22	42.12	20.58	40.51	19.89	37.29	18.52	34.07	17.16	30.84	15.80	27.61	14.46	24.37	13.18
		19	34.64	23.22	33.11	22.48	30.05	21.01	26.97	19.55	23.89	18.12	20.80	16.74	17.71	15.49
		16	28.76	26.41	27.26	25.39	24.26	23.38	21.25	21.25	18.22	18.22	15.17	15.17	12.10	12.10
	1400 .10	22	49.07	24.22	47.14	23.49	43.29	22.02	39.43	20.56	35.57	19.12	31.71	17.72	27.85	16.48
		19	40.52	27.88	38.72	27.04	35.13	25.38	31.54	23.74	27.94	22.15	24.33	20.67	20.71	19.62
		16	33.30	32.38	31.70	31.12	28.48	28.48	25.25	25.25	22.01	22.01	18.76	18.76	15.50	15.50
	1800 .12	22	54.60	27.31	52.46	26.52	48.17	24.95	43.89	23.40	39.61	21.87	35.32	20.41	31.04	19.32
		19	45.87	31.43	43.80	30.60	39.68	28.96	35.55	27.35	31.42	25.81	27.28	24.47	23.14	23.14
		16	36.21	36.21	34.59	34.59	31.35	31.35	28.10	28.10	24.85	24.85	21.59	21.59	18.33	18.33
120	1450 .05	22	56.46	26.00	54.28	25.26	49.91	23.80	45.53	22.33	41.15	20.89	36.77	19.47	32.38	18.13
		19	46.83	30.42	44.73	29.53	40.53	27.76	36.32	26.01	32.10	24.29	27.87	22.64	23.64	21.21
		16	38.11	34.82	36.21	33.56	32.39	31.04	28.56	28.55	24.71	24.71	20.85	20.85	16.97	16.97
	1900 .07	22	65.14	31.89	62.64	30.94	57.64	29.05	52.64	27.17	47.63	25.30	42.62	23.47	37.61	21.73
		19	54.26	36.83	51.85	35.78	47.03	33.70	42.19	31.64	37.35	29.61	32.51	27.68	27.65	26.01
		16	44.18	43.13	42.12	41.49	37.99	37.99	33.85	33.85	29.71	29.71	25.55	25.55	21.37	21.37
	2350 .12	22	71.98	35.85	69.21	34.85	63.67	32.86	58.13	30.89	52.59	28.93	47.05	27.03	41.51	25.31
		19	60.62	42.44	57.89	41.30	52.41	39.02	46.93	36.77	41.45	34.59	35.97	32.55	30.49	30.49
		16	47.82	47.82	45.79	45.79	41.72	41.72	37.66	37.66	33.59	33.59	29.52	29.52	25.44	25.44
150	1750 .06	22	65.89	31.93	63.44	30.98	58.55	29.09	53.65	27.21	48.75	25.34	43.85	23.49	38.94	21.73
		19	55.70	36.93	53.09	35.77	47.85	33.46	42.61	31.18	37.35	28.93	32.09	26.75	26.81	24.76
		16	44.35	42.14	42.24	40.60	38.02	37.55	33.78	33.78	29.53	29.53	25.27	25.27	20.98	20.98
	2350 .08	22	75.61	37.49	72.79	36.44	67.15	34.34	61.51	32.26	55.87	30.19	50.23	28.16	44.58	26.26
		19	63.64	44.28	60.75	43.02	54.97	40.53	49.19	38.06	43.40	35.64	37.61	33.33	31.81	31.36
		16	50.09	50.09	47.97	47.97	43.71	43.71	39.44	39.44	35.17	35.17	30.90	30.90	26.62	26.62
	2950 .10	22	83.01	42.04	79.93	40.94	73.75	38.75	67.58	36.57	61.41	34.42	55.23	32.34	49.06	30.52
		19	67.98	49.45	65.08	48.26	59.28	45.89	53.48	43.57	47.68	41.33	41.88	39.29	36.08	36.08
		16	54.67	54.67	52.53	52.53	48.24	48.24	43.96	43.96	39.67	39.67	35.38	35.38	31.10	31.10
180	2100 .03	22	82.25	39.79	79.12	38.58	72.88	36.16	66.62	33.74	60.37	31.34	54.10	28.97	47.84	26.65
		16	68.47	45.43	65.39	44.06	59.24	41.32	53.07	38.61	46.89	35.94	40.70	33.33	34.50	30.88
		16	55.23	51.82	52.57	49.96	47.23	46.25	41.88	41.88	36.52	36.52	31.13	31.13	25.73	25.73
	2800 .05	22	94.97	46.65	91.32	45.28	84.03	42.55	76.72	39.83	69.42	37.13	62.11	34.48	54.80	31.95
		19	79.48	54.48	75.93	52.91	68.84	49.78	61.73	46.68	54.62	43.64	47.50	40.72	40.37	38.14
		16	64.12	63.23	61.19	60.85	55.34	55.34	49.48	49.48	43.61	43.61	37.72	37.72	31.82	31.82
	3500 .08	22	102.66	51.90	98.96	50.54	91.55	47.82	84.14	45.12	76.73	42.46	69.32	39.90	61.90	37.72
		19	85.35	62.06	81.75	60.40	74.54	57.09	67.33	53.84	60.11	50.69	52.89	47.79	45.66	45.66
		16	69.63	69.63	66.75	66.75	60.99	60.99	55.23	55.23	49.45	49.45	43.67	43.67	37.88	37.88

See Legend on following page.

PERFORMANCE DATA: BAC SERIES, COOLING CAPACITIES — SI

Unit BAC	EVAPORATOR AIR		COIL REFRIGERANT TEMP (C)													
	Airflow (L/s) BF	Ewb (C)	-1		0		2		4		6		8		10	
			TC	SHC	TC	SHC	TC	SHC	TC	SHC	TC	SHC	TC	SHC	TC	SHC
240	2900 .03	22	106.58	52.05	102.62	50.46	94.70	47.29	86.78	44.13	78.85	40.98	70.92	37.84	62.99	34.74
		19	89.80	59.51	85.74	57.82	77.63	54.44	69.50	51.08	61.37	47.75	53.21	44.47	45.05	41.29
		16	71.75	68.29	68.44	65.88	61.79	61.08	55.13	55.13	48.45	48.45	41.75	41.75	35.03	35.03
	3800 .06	22	122.11	60.50	117.57	58.81	108.48	55.45	99.38	52.11	90.29	48.79	81.19	45.52	72.10	42.39
		19	99.07	69.97	94.89	68.20	86.53	64.66	78.16	61.17	69.79	57.74	61.41	54.46	53.03	51.58
		16	80.95	80.95	77.60	77.60	70.90	70.90	64.19	64.19	57.48	57.48	50.76	50.76	44.03	44.03
	4700 .072	21	33.27	67.86	128.35	66.08	118.51	62.52	108.68	58.97	98.84	55.46	89.00	52.01	79.16	48.77
		19	109.55	80.54	104.99	78.62	95.88	74.79	86.76	71.01	77.65	67.33	68.53	63.85	59.41	59.41
		16	88.34	88.34	84.97	84.97	78.24	78.24	71.50	71.50	64.76	64.76	58.02	58.02	51.28	51.28

Unit BAC (High Capacity 4 row coil)	EVAPORATOR AIR		COIL REFRIGERANT TEMP (C)									
	Airflow (L/s) BF	Ewb (C)	-1		2		4		7		10	
			TC	SHC	TC	SHC	TC	SHC	TC	SHC	TC	SHC
245	2830 .04	22	120	58	109	53	97	48	80	41	68	36
		19	101	62	90	57	78	52	64	46	50	40
		17	84	67	73	61	61	55	48	48	41	41
	3780 .06	22	138	67	126	62	112	56	96	50	79	43
		19	117	74	105	68	91	62	75	56	58	49
		17	98	81	85	74	71	67	59	59	50	50
	4720 .080	22	151	74	138	69	123	63	106	56	87	49
		19	129	84	116	78	100	71	83	64	64	57
		17	108	93	94	86	79	78	68	68	58	58

LEGEND FOR PERFORMANCE TABLES - SI

LEGEND

- BF** — Bypass Factor
Edb — Entering Dry-Bulb
Ewb — Entering Wet-Bulb
Ldb — Leaving Dry-Bulb
Lwb — Leaving Wet-Bulb
SHC — Sensible Heat Capacity (kW)
TC — Total Capacity (kW)

NOTES:

- Ratings based on approximately 8.3 C superheat leaving coil.
- Direct interpolation is permissible. Do not extrapolate.
- The SHC is based on 26.7 C db temperature of air entering the unit. At any other temperature, correct the SHC reading from the table of cooling capacities as follows:

$$\text{Correction factor} = 1.23 \times 10^{-3} \times (1 - \text{BF}) \times (\text{db} - 26.7)$$

Above 26.7 C, add SHC correction to SHC. Below 26.7 C, subtract SHC correction from SHC.

- Gross capacities shown do not include a deduction for evaporator-fan motor heat.
- Formulas (cooling):

$$t_{\text{ldb}} = t_{\text{edb}} - \frac{\text{sensible heat capacity (kW)}}{1.23 \times 10^{-3} \times (\text{L/s})}$$

t_{lwb} = wet-bulb temperature corresponding to enthalpy of air leaving coil (h_{lwb})

$$h_{\text{lwb}} = h_{\text{ewb}} - \frac{\text{total capacity (kW)}}{1.20 \times 10^{-3} \times (\text{L/s})}$$

where h_{ewb} = enthalpy of air entering coil (kJ/kg)

PERFORMANCE DATA: BHC SERIES, COOLING CAPACITIES — ENGLISH

UNIT BHC	EVAPORATOR AIR		COIL REFRIGERANT TEMP (F)									
	Airflow (Cfm) BF	Ewb (F)	30		35		40		45		50	
			TC	SHC	TC	SHC	TC	SHC	TC	SHC	TC	SHC
090	2250 0.06	72	144	69	130	63	116	57	99	50	80	43
		67	120	76	106	70	92	63	76	56	59	50
		62	100	83	87	76	71	69	57	57	49	49
	3000 0.10	72	169	81	151	75	135	68	114	61	94	53
		67	140	92	124	85	108	77	89	69	69	62
		62	118	101	102	94	84	84	70	70	59	59
	3750 0.12	72	187	92	168	85	150	78	127	70	104	61
		67	157	106	140	97	120	89	100	81	77	72
		62	132	118	112	108	94	94	80	80	68	68
120	3000 0.05	72	193	92	174	81	154	76	132	67	108	58
		67	161	102	143	93	123	85	102	76	79	67
		62	134	111	116	102	96	93	78	78	66	66
	4000 0.07	72	223	108	201	99	179	91	153	81	125	71
		67	186	122	166	113	143	104	119	93	92	82
		62	157	136	136	126	113	113	95	95	80	80
	5000 0.12	72	246	122	222	112	198	103	169	93	138	81
		67	207	140	185	131	159	120	132	109	102	97
		62	175	159	149	145	126	126	109	109	92	92
180	4500 0.04	72	310	147	282	135	250	122	212	107	175	93
		67	258	161	231	148	199	135	165	120	126	105
		62	213	175	185	161	154	146	122	122	102	102
	6000 0.04	72	366	176	331	161	293	146	248	130	205	114
		67	304	196	272	182	234	166	194	149	149	132
		62	254	217	219	201	181	181	148	148	125	125
	7500 0.05	72	409	199	371	185	327	168	277	150	228	132
		67	339	227	303	211	263	194	217	176	168	156
		62	285	255	244	236	205	205	172	172	146	146

See Legend on page 18

PERFORMANCE DATA: BHC SERIES, COOLING CAPACITIES — SI

BHC	EVAPORATOR AIR		COIL REFRIGERANT TEMP (C)													
	Airflow (L/s) BF	Ewb (C)	-1		0		2		4		6		8		10	
			TC	SHC	TC	SHC	TC	SHC	TC	SHC	TC	SHC	TC	SHC	TC	SHC
090	1000 .06	22	42.12	20.58	40.51	19.89	37.29	18.52	34.07	17.16	30.84	15.80	27.61	14.46	24.37	13.18
		19	34.64	23.22	33.11	22.48	30.05	21.01	26.97	19.55	23.89	18.12	20.80	16.74	17.71	15.49
		16	28.76	26.41	27.26	25.39	24.26	23.38	21.25	21.25	18.22	18.22	15.17	15.17	12.10	12.10
	1400 .10	22	49.07	24.22	47.14	23.49	43.29	22.02	39.43	20.56	35.57	19.12	31.71	17.72	27.85	16.48
		19	40.52	27.88	38.72	27.04	35.13	25.38	31.54	23.74	27.94	22.15	24.33	20.67	20.71	19.62
		16	33.30	32.38	31.70	31.12	28.48	28.48	25.25	25.25	22.01	22.01	18.76	18.76	15.50	15.50
	1800 .12	22	54.60	27.31	52.46	26.52	48.17	24.95	43.89	23.40	39.61	21.87	35.32	20.41	31.04	19.32
		19	45.87	31.43	43.80	30.60	39.68	28.96	35.55	27.35	31.42	25.81	27.28	24.47	23.14	23.14
		16	36.21	36.21	34.59	34.59	31.35	31.35	28.10	28.10	24.85	24.85	21.59	21.59	18.33	18.33
120	1450 .05	22	56.46	26.00	54.28	25.26	49.91	23.80	45.53	22.33	41.15	20.89	36.77	19.47	32.38	18.13
		19	46.83	30.42	44.73	29.53	40.53	27.76	36.32	26.01	32.10	24.29	27.87	22.64	23.64	21.21
		16	38.11	34.82	36.21	33.56	32.39	31.04	28.56	28.55	24.71	24.71	20.85	20.85	16.97	16.97
	1900 .07	22	65.14	31.89	62.64	30.94	57.64	29.05	52.64	27.17	47.63	25.30	42.62	23.47	37.61	21.73
		19	54.26	36.83	51.85	35.78	47.03	33.70	42.19	31.64	37.35	29.61	32.51	27.68	27.65	26.01
		16	44.18	43.13	42.12	41.49	37.99	37.99	33.85	33.85	29.71	29.71	25.55	25.55	21.37	21.37
	2350 .12	22	71.98	35.85	69.21	34.85	63.67	32.86	58.13	30.89	52.59	28.93	47.05	27.03	41.51	25.31
		19	60.62	42.44	57.89	41.30	52.41	39.02	46.93	36.77	41.45	34.59	35.97	32.55	30.49	30.49
		16	47.82	47.82	45.79	45.79	41.72	41.72	37.66	37.66	33.59	33.59	29.52	29.52	25.44	25.44
180	2100 .04	22	91.80	44.17	88.16	42.69	80.87	39.73	73.57	36.78	66.27	33.84	58.97	30.93	51.65	28.08
		19	75.66	48.99	72.28	47.51	65.51	44.55	58.73	41.62	51.94	38.73	45.13	35.92	38.31	33.27
		16	61.18	56.01	58.01	53.92	51.67	49.75	45.31	45.31	38.92	38.92	32.51	32.51	26.06	26.06
	2800 .04	22	107.87	52.14	103.54	50.51	94.89	47.27	86.24	44.04	77.57	40.86	68.91	37.79	60.23	35.23
		19	89.13	59.53	85.12	57.81	77.11	54.40	69.08	51.05	61.05	47.81	53.00	44.90	44.93	43.44
		16	71.93	69.52	68.35	66.73	61.19	61.19	54.01	54.01	46.81	46.81	39.59	39.59	32.34	32.34
	3500 .05	22	121.08	59.76	116.17	57.92	106.35	54.26	96.52	50.62	86.70	47.03	76.87	43.59	67.04	63.63
		19	99.24	68.38	94.81	66.56	85.93	62.96	77.04	59.43	68.15	56.05	59.26	53.09	50.35	50.35
		16	79.29	79.29	75.63	75.63	68.32	68.32	61.00	61.00	53.67	53.67	46.33	46.33	38.98	38.98

See Legend on page 18

HYDRONIC HEATING CAPACITIES — ENGLISH

UNIT	AIRFLOW (Cfm)	1-ROW STEAM*		2-ROW HOT WATER COIL†			
		Cap.	Ldb	Cap.	Ldb	Water Flow (Gpm)	PD
BAC 007	1,800	146	134	156.0	140	15.6	3.4
	2,400	173	126	183.0	131	18.3	4.3
	3,000	209	123	206.0	124	20.6	5.2
BAC BHC090	2,250	168	129	174.0	133	17.4	4.0
	3,000	209	123	206.0	124	20.6	5.2
	3,750	240	117	238.0	118	23.8	6.5
BAC BHC 120	3,000	209	123	299.0	152	29.9	5.0
	4,000	243	115	275.0	124	27.5	6.6
	5,000	279	111	316.0	119	31.6	8.2
BAC 150	3,750	370	150	362.0	149	36.2	4.2
	5,000	425	137	409.0	136	40.9	5.1
	6,250	465	128	456.0	128	45.6	6.0
BAC BHC 180	4,500	402	141	412.0	145	41.2	4.5
	6,000	458	129	471.0	133	47.1	5.5
	7,500	479	118	529.0	125	52.9	6.6
BAC 240/245	6,000	458	129	506.0	138	50.6	5.1
	8,000	487	115	584.0	128	58.4	6.3
	10,000	499	105	652.0	120	65.2	7.5

LEGEND

Cap. —Capacity (Btuh in thousands)
 Ldb —Leaving-Air Dry-Bulb Temp (F)
 PD —Pressure Drop (ft water)

*Based on 5 psig steam, 60 F entering-air temperature. All steam coils are non-freeze type.
 †Based on 200 F entering water, 20 F water temperature drop, 60 F entering-air temperature.

NOTES:

- Maximum operating limits for heating coils: 175 psig at 400 F.
- Leaving db = ent db (F) + $\frac{\text{Capacity (Btuh)}}{1.1 \times \text{cfm}}$
- See Heating Correction Factors table.

HEATING CORRECTION FACTORS — ENGLISH

HOT WATER COIL						
Water Temp Drop (F)	Ent Water Temp (F)	Entering-Air Temp (F)				
		40	50	60	70	80
10	140	0.72	0.64	0.57	0.49	0.41
	160	0.89	0.81	0.74	0.66	0.58
	180	1.06	0.98	0.90	0.83	0.75
	200	1.22	1.15	1.07	1.00	0.92
	220	1.39	1.32	1.24	1.17	1.09
20	140	0.64	0.57	0.49	0.41	0.33
	160	0.81	0.74	0.66	0.58	0.51
	180	0.98	0.91	0.83	0.75	0.68
	200	1.15	1.08	1.00	0.93	0.85
	220	1.32	1.25	1.17	1.10	1.02
30	140	0.56	0.49	0.41	0.33	0.24
	160	0.74	0.66	0.58	0.51	0.43
	180	0.91	0.83	0.76	0.68	0.60
	200	1.08	1.00	0.93	0.85	0.78
	220	1.25	1.18	1.10	1.03	0.95

STEAM COIL					
Steam Pressure (psig)	Entering-Air Temp (F)				
	40	50	60	70	80
0	1.06	0.98	0.91	0.85	0.78
2	1.09	1.02	0.95	0.89	0.82
5	1.13	1.06	1.00	0.93	0.87

NOTE: Multiply capacity given in the Hydronic Heating Capacities table by the correction factor for conditions at which unit is actually operating. Correct leaving-air temperature using formula in Note 2 of Hydronic Heating Capacities table.

HYDRONIC HEATING CAPACITIES — SI

UNIT	AIRFLOW (L/s)	1-ROW STEAM*		2-ROW HOT WATER COIL†			
		Cap.	Ldb	Cap.	Ldb	Water Flow (L/s)	PD
BAC 075	850	43	57	46	59	1.0	10.2
	1150	53	53	53	53	1.2	12.8
	1450	62	51	61	50	1.3	16.0
BAC BHC 090	1000	48	55	50	56	1.1	11.5
	1400	59	50	60	50	1.3	15.3
	1800	71	47	70	47	1.5	19.5
BAC BHC 120	1450	62	50	88	65	1.9	15.0
	1900	72	46	90	54	2.0	24.7
	2350	82	44	93	48	2.0	24.5
BAC 150	1750	108	66	106	65	2.3	12.4
	2350	122	58	120	57	2.6	15.2
	2950	136	53	134	52	2.9	17.9
BAC BHC 180	2100	117	61	120	62	2.6	13.3
	2800	129	53	137	55	3.0	16.2
	3500	140	48	154	51	3.3	19.5
BAC 240/245	2900	135	53	150	58	3.3	15.6
	3800	140	46	170	52	3.7	18.6
	4700	146	41	191	49	4.1	22.3

LEGEND

Cap. —Capacity (kW)
 Ldb —Leaving-Air Dry-Bulb Temp (C)
 PD —Pressure Drop (kPa)

*Based on 34.5 kPag steam, 15.6 C entering-air temperature. All steam coils are non-freeze type.
 †Based on 93.3 C entering water temperature, 11.1 C water temperature drop, 15.6 C entering-air temperature.

NOTES:

- Maximum operating limits for heating coils: 1207 kPag at 204.4 C.
- Leaving db = ent db (C) + $\frac{\text{Capacity (kw)}}{1.23 \times 10^{-3} \times \text{IL/s}}$
- See Heating Correction Factors table.

HEATING CORRECTION FACTORS — SI

HOT WATER COIL						
Water Temp Drop (C)	Ent Water Temp (C)	Entering-Air Temp (C)				
		4	10	16	20	25
5	60	0.72	0.64	0.55	0.50	0.43
	70	0.87	0.79	0.71	0.65	0.58
	80	1.02	0.94	0.86	0.80	0.73
	90	1.17	1.09	1.01	0.95	0.89
	100	1.32	1.24	1.16	1.10	1.04
11	60	0.65	0.56	0.48	0.42	0.35
	70	0.80	0.72	0.63	0.58	0.51
	80	0.95	0.87	0.79	0.73	0.66
	90	1.10	1.02	0.94	0.89	0.82
	100	1.26	1.18	1.09	1.04	0.97
16	60	0.56	0.48	0.39	0.33	0.26
	70	0.72	0.63	0.55	0.49	0.42
	80	0.87	0.79	0.70	0.65	0.58
	90	1.02	0.94	0.86	0.81	0.74
	100	1.18	1.10	1.02	0.97	0.90

STEAM COIL					
Steam Pressure (kPag)	Entering-Air Temp (C)				
	4	10	16	20	25
0	1.07	0.99	0.91	0.86	0.80
14	1.10	1.02	0.95	0.90	0.84
16	1.14	1.07	0.99	0.95	0.89

NOTE: Multiply capacity given in the Hydronic Heating Capacities table by the correction factor for conditions at which unit is actually operating. Correct leaving-air temperature using formula in Note 2 of Hydronic Heating Capacities table.

FAN PERFORMANCE DATA — 0.0-1.2 in. wg ESP — 60 Hz, ENGLISH

UNIT	AIRFLOW (Cfm)	EXTERNAL STATIC PRESSURE (in. wg)													
		0.0		0.2		0.4		0.6		0.8		1.0		1.2	
		Rpm	Bhp	Rpm	Bhp	Rpm	Bhp	Rpm	Bhp	Rpm	Bhp	Rpm	Bhp	Rpm	Bhp
BAC 075	1,800	320	0.22	442	0.32	534	0.42	611	0.52	<u>678</u>	<u>0.61</u>	<u>739</u>	<u>0.70</u>	<u>795</u>	<u>0.80</u>
	2,100	373	0.31	483	0.42	569	0.53	642	0.63	<u>708</u>	<u>0.73</u>	<u>767</u>	<u>0.82</u>	<u>821</u>	<u>0.92</u>
	2,400	427	0.42	526	0.53	606	0.64	676	0.75	<u>739</u>	<u>0.86</u>	<u>796</u>	<u>0.96</u>	<u>849</u>	<u>1.06</u>
	2,700	480	0.54	570	0.67	646	0.78	712	0.89	<u>773</u>	<u>1.00</u>	<u>828</u>	<u>1.11</u>	<u>880</u>	<u>1.21</u>
	3,000	533	0.69	616	0.82	687	0.94	750	1.05	<u>808</u>	<u>1.16</u>	<u>862</u>	<u>1.28</u>	<u>912</u>	<u>1.39</u>
BAC BHC 090	2,250	359	0.32	472	0.44	560	0.55	634	0.65	700	0.75	<u>759</u>	<u>0.86</u>	<u>814</u>	<u>0.96</u>
	2,600	415	0.45	516	0.57	599	0.68	669	0.79	732	0.90	<u>790</u>	<u>1.01</u>	<u>843</u>	<u>1.11</u>
	3,000	478	0.62	569	0.75	645	0.86	712	0.98	<u>773</u>	<u>1.09</u>	<u>828</u>	<u>1.20</u>	<u>879</u>	<u>1.32</u>
	3,400	542	0.82	624	0.95	695	1.08	<u>758</u>	<u>1.20</u>	<u>815</u>	<u>1.31</u>	<u>869</u>	<u>1.43</u>	<u>918</u>	<u>1.55</u>
	3,750	598	1.03	673	1.17	<u>740</u>	<u>1.29</u>	<u>800</u>	<u>1.42</u>	<u>855</u>	<u>1.60</u>	<u>906</u>	<u>1.66</u>	<u>954</u>	<u>1.78</u>
BAC 120	3,000	444	0.58	541	0.71	621	0.83	691	0.94	753	1.05	809	1.17	<u>862</u>	<u>1.28</u>
	3,500	518	0.82	604	0.95	677	1.08	742	1.20	801	1.32	855	1.44	<u>906</u>	<u>1.56</u>
	4,000	592	1.11	669	1.25	736	1.38	797	1.51	853	1.63	<u>904</u>	<u>1.75</u>	<u>953</u>	<u>1.88</u>
	4,500	666	1.44	735	1.59	797	1.72	854	1.86	<u>907</u>	<u>1.99</u>	<u>956</u>	<u>2.12</u>	<u>1003</u>	<u>2.24</u>
	5,000	740	1.83	803	1.98	861	2.12	914	2.26	<u>964</u>	<u>2.39</u>	<u>1010</u>	<u>2.53</u>	<u>1055</u>	<u>2.66</u>
BHC 120	3,000	471	0.61	564	0.74	642	0.86	710	0.97	771	1.09	827	1.20	<u>878</u>	<u>1.31</u>
	3,500	550	0.87	632	1.00	703	1.13	766	1.25	824	1.37	<u>877</u>	<u>1.49</u>	<u>926</u>	<u>1.60</u>
	4,000	628	1.17	701	1.31	766	1.44	825	1.57	<u>879</u>	<u>1.69</u>	<u>930</u>	<u>1.82</u>	<u>978</u>	<u>1.94</u>
	4,500	706	1.53	772	1.67	832	1.81	887	1.94	<u>938</u>	<u>2.07</u>	<u>987</u>	<u>2.20</u>	<u>1032</u>	<u>2.33</u>
	5,000	785	1.93	845	2.08	<u>900</u>	<u>2.22</u>	<u>952</u>	<u>2.36</u>	<u>1000</u>	<u>2.50</u>	<u>1045</u>	<u>2.63</u>	<u>1089</u>	<u>2.76</u>
BAC 150	3,750	363	0.37	475	0.58	566	0.80	645	1.02	715	1.24	<u>779</u>	<u>1.47</u>	<u>839</u>	<u>1.69</u>
	4,300	416	0.53	517	0.78	601	1.02	676	1.26	<u>743</u>	<u>1.50</u>	<u>805</u>	<u>1.74</u>	<u>862</u>	<u>1.99</u>
	5,000	484	0.81	573	1.08	650	1.35	719	1.62	<u>782</u>	<u>1.89</u>	<u>841</u>	<u>2.16</u>	<u>896</u>	<u>2.44</u>
	5,700	552	1.17	631	1.47	702	1.76	<u>766</u>	<u>2.06</u>	<u>826</u>	<u>2.36</u>	<u>881</u>	<u>2.66</u>	<u>934</u>	<u>2.96</u>
	6,250	605	1.51	678	1.83	<u>744</u>	<u>2.15</u>	<u>805</u>	<u>2.47</u>	<u>862</u>	<u>2.79</u>	<u>915</u>	<u>3.11</u>	<u>966</u>	<u>3.43</u>
BAC 180	4,500	391	0.51	495	0.75	581	1.00	657	1.25	725	1.50	<u>787</u>	<u>1.76</u>	<u>845</u>	<u>2.02</u>
	5,300	460	0.80	551	1.08	629	1.35	700	1.63	<u>764</u>	<u>1.91</u>	<u>823</u>	<u>2.20</u>	<u>878</u>	<u>2.48</u>
	6,000	521	1.13	602	1.43	675	1.73	741	2.04	<u>801</u>	<u>2.34</u>	<u>858</u>	<u>2.65</u>	<u>911</u>	<u>2.96</u>
	6,800	590	1.60	663	1.93	<u>730</u>	<u>2.26</u>	<u>791</u>	<u>2.59</u>	<u>847</u>	<u>2.92</u>	<u>901</u>	<u>3.26</u>	<u>951</u>	<u>3.60</u>
	7,500	651	2.10	718	2.45	<u>779</u>	<u>2.81</u>	<u>837</u>	<u>3.16</u>	<u>890</u>	<u>3.52</u>	<u>941</u>	<u>3.88</u>	<u>990</u>	<u>4.24</u>
BHC 180	4,500	405	0.54	507	0.79	592	1.03	667	1.28	<u>735</u>	<u>1.54</u>	<u>797</u>	<u>1.80</u>	<u>854</u>	<u>2.06</u>
	5,300	476	0.85	566	1.13	643	1.40	713	1.68	<u>776</u>	<u>1.97</u>	<u>835</u>	<u>2.26</u>	<u>890</u>	<u>2.55</u>
	6,000	539	1.20	620	1.50	691	1.81	<u>756</u>	<u>2.11</u>	<u>816</u>	<u>2.42</u>	<u>872</u>	<u>2.73</u>	<u>924</u>	<u>3.05</u>
	6,800	611	1.69	683	2.03	<u>748</u>	<u>2.36</u>	<u>809</u>	<u>2.69</u>	<u>865</u>	<u>3.03</u>	<u>918</u>	<u>3.37</u>	<u>968</u>	<u>3.71</u>
	7,500	674	2.22	<u>740</u>	<u>2.58</u>	<u>800</u>	<u>2.93</u>	<u>857</u>	<u>3.29</u>	<u>910</u>	<u>3.65</u>	<u>960</u>	<u>4.02</u>	<u>1008</u>	<u>4.38</u>
BAC 240/245	6,000	503	1.07	587	1.37	661	1.67	727	1.97	789	2.28	846	2.59	<u>900</u>	<u>2.90</u>
	7,000	586	1.64	660	1.98	726	2.31	787	2.65	844	2.99	<u>898</u>	<u>3.33</u>	<u>948</u>	<u>3.67</u>
	8,000	670	2.37	735	2.74	795	3.12	851	3.49	<u>904</u>	<u>3.86</u>	<u>954</u>	<u>4.23</u>	<u>1001</u>	<u>4.61</u>
	9,000	754	3.28	812	3.69	<u>867</u>	<u>4.09</u>	<u>918</u>	<u>4.50</u>	<u>967</u>	<u>4.90</u>	<u>1014</u>	<u>5.31</u>	<u>1059</u>	<u>5.72</u>
	10,000	838	4.39	<u>891</u>	<u>4.83</u>	<u>941</u>	<u>5.27</u>	<u>988</u>	<u>5.70</u>	<u>1034</u>	<u>6.14</u>	<u>1077</u>	<u>6.85</u>	<u>1120</u>	<u>7.02</u>

See Legend and Notes on page 24.

FAN PERFORMANCE DATA — 1.4-2.4 in. wg ESP — 60 Hz, ENGLISH

UNIT	AIRFLOW (Cfm)	EXTERNAL STATIC PRESSURE (in.wg)											
		1.4		1.6		1.8		2.0		2.2		2.4	
		Rpm	Bhp	Rpm	Bhp	Rpm	Bhp	Rpm	Bhp	Rpm	Bhp	Rpm	Bhp
BAC 075	1,800	<u>847</u>	<u>0.89</u>	<u>896</u>	<u>0.98</u>	<u>942</u>	<u>1.07</u>	<u>986</u>	<u>1.16</u>	<u>1027</u>	<u>1.25</u>	—	—
	2,100	<u>872</u>	<u>1.02</u>	<u>920</u>	<u>1.11</u>	<u>965</u>	<u>1.21</u>	<u>1008</u>	<u>1.30</u>	<u>1050</u>	<u>1.40</u>	—	—
	2,400	<u>899</u>	<u>1.16</u>	<u>946</u>	<u>1.26</u>	<u>990</u>	<u>1.36</u>	<u>1033</u>	<u>1.46</u>	<u>1073</u>	<u>1.55</u>	—	—
	2,700	<u>928</u>	<u>1.32</u>	<u>974</u>	<u>1.42</u>	<u>1018</u>	<u>1.52</u>	<u>1059</u>	<u>1.63</u>	1099	1.73	—	—
	3,000	<u>959</u>	<u>1.49</u>	<u>1004</u>	<u>1.60</u>	<u>1046</u>	<u>1.71</u>	1087	1.81	1126	1.92	—	—
BAC BHC 090	2,250	<u>865</u>	<u>1.06</u>	<u>913</u>	<u>1.16</u>	<u>958</u>	<u>1.27</u>	<u>1001</u>	<u>1.37</u>	<u>1042</u>	<u>1.47</u>	—	—
	2,600	<u>893</u>	<u>1.22</u>	<u>940</u>	<u>1.33</u>	<u>984</u>	<u>1.43</u>	<u>1027</u>	<u>1.54</u>	<u>1067</u>	<u>1.65</u>	—	—
	3,000	<u>928</u>	<u>1.43</u>	<u>973</u>	<u>1.54</u>	<u>1017</u>	<u>1.65</u>	<u>1058</u>	<u>1.76</u>	<u>1098</u>	<u>1.87</u>	—	—
	3,400	<u>965</u>	<u>1.66</u>	<u>1010</u>	<u>1.78</u>	<u>1052</u>	<u>1.89</u>	<u>1092</u>	<u>2.00</u>	<u>1131</u>	<u>2.12</u>	—	—
	3,750	<u>1000</u>	<u>1.90</u>	<u>1043</u>	<u>2.02</u>	<u>1084</u>	<u>2.13</u>	<u>1124</u>	<u>2.25</u>	<u>1162</u>	<u>2.37</u>	—	—
BAC 120	3,000	<u>911</u>	<u>1.39</u>	<u>958</u>	<u>1.50</u>	<u>1002</u>	<u>1.61</u>	<u>1044</u>	<u>1.72</u>	<u>1084</u>	<u>1.83</u>	<u>1123</u>	<u>1.94</u>
	3,500	<u>953</u>	<u>1.67</u>	<u>998</u>	<u>1.79</u>	<u>1041</u>	<u>1.90</u>	<u>1082</u>	<u>2.02</u>	<u>1122</u>	<u>2.13</u>	<u>1159</u>	<u>2.25</u>
	4,000	<u>999</u>	<u>2.00</u>	<u>1042</u>	<u>2.12</u>	<u>1084</u>	<u>2.24</u>	<u>1124</u>	<u>2.36</u>	<u>1162</u>	<u>2.48</u>	<u>1199</u>	<u>2.60</u>
	4,500	<u>1047</u>	<u>2.37</u>	<u>1089</u>	<u>2.50</u>	<u>1129</u>	<u>2.62</u>	<u>1168</u>	<u>2.74</u>	—	—	—	—
	5,000	<u>1097</u>	<u>2.79</u>	<u>1138</u>	<u>2.92</u>	<u>1177</u>	<u>3.05</u>	—	—	—	—	—	—
BHC 120	3,000	<u>927</u>	<u>1.43</u>	<u>973</u>	<u>1.54</u>	<u>1017</u>	<u>1.65</u>	<u>1058</u>	<u>1.76</u>	<u>1098</u>	<u>1.87</u>	<u>1137</u>	<u>1.98</u>
	3,500	<u>973</u>	<u>1.72</u>	<u>1018</u>	<u>1.84</u>	<u>1060</u>	<u>1.95</u>	<u>1101</u>	<u>2.07</u>	<u>1139</u>	<u>2.18</u>	<u>1177</u>	<u>2.30</u>
	4,000	<u>1023</u>	<u>2.06</u>	<u>1066</u>	<u>2.19</u>	<u>1107</u>	<u>2.31</u>	<u>1146</u>	<u>2.43</u>	<u>1184</u>	<u>2.55</u>	—	—
	4,500	<u>1075</u>	<u>2.45</u>	<u>1116</u>	<u>2.58</u>	<u>1156</u>	<u>2.71</u>	<u>1194</u>	<u>2.83</u>	—	—	—	—
	5,000	<u>1130</u>	<u>2.90</u>	<u>1170</u>	<u>3.03</u>	—	—	—	—	—	—	—	—
BAC 150	3,750	<u>894</u>	<u>1.91</u>	<u>947</u>	<u>2.14</u>	<u>996</u>	<u>2.37</u>	<u>1044</u>	<u>2.60</u>	<u>1089</u>	<u>2.83</u>	—	—
	4,300	<u>916</u>	<u>2.23</u>	<u>967</u>	<u>2.48</u>	<u>1016</u>	<u>2.73</u>	<u>1062</u>	<u>2.98</u>	1107	3.24	—	—
	5,000	<u>948</u>	<u>2.71</u>	<u>997</u>	<u>2.98</u>	<u>1044</u>	<u>3.26</u>	<u>1089</u>	<u>3.53</u>	1133	3.81	—	—
	5,700	<u>984</u>	<u>3.25</u>	<u>1031</u>	<u>3.55</u>	<u>1076</u>	<u>3.86</u>	1120	4.16	<u>1162</u>	<u>4.46</u>	—	—
	6,250	<u>1014</u>	<u>3.75</u>	<u>1060</u>	<u>4.07</u>	<u>1104</u>	<u>4.39</u>	<u>1147</u>	<u>4.71</u>	<u>1188</u>	<u>5.03</u>	—	—
BAC 180	4,500	<u>899</u>	<u>2.29</u>	<u>951</u>	<u>2.56</u>	<u>999</u>	<u>2.84</u>	<u>1046</u>	<u>3.12</u>	<u>1091</u>	<u>3.41</u>	<u>1133</u>	<u>3.70</u>
	5,300	<u>930</u>	<u>2.78</u>	<u>980</u>	<u>3.08</u>	<u>1027</u>	<u>3.38</u>	<u>1072</u>	<u>3.68</u>	<u>1116</u>	<u>3.99</u>	<u>1157</u>	<u>4.30</u>
	6,000	<u>961</u>	<u>3.28</u>	<u>1009</u>	<u>3.60</u>	<u>1055</u>	<u>3.92</u>	<u>1098</u>	<u>4.24</u>	<u>1141</u>	<u>4.57</u>	<u>1181</u>	<u>4.91</u>
	6,800	<u>999</u>	<u>3.94</u>	<u>1045</u>	<u>4.28</u>	<u>1089</u>	<u>4.63</u>	<u>1132</u>	<u>4.98</u>	<u>1173</u>	<u>5.33</u>	—	—
	7,500	<u>1036</u>	<u>4.60</u>	<u>1080</u>	<u>4.97</u>	<u>1123</u>	<u>5.34</u>	<u>1164</u>	<u>5.71</u>	—	—	—	—
BHC 180	4,500	<u>908</u>	<u>2.33</u>	<u>959</u>	<u>2.61</u>	<u>1008</u>	<u>2.89</u>	<u>1054</u>	<u>3.17</u>	<u>1098</u>	<u>3.46</u>	<u>1141</u>	<u>3.75</u>
	5,300	<u>941</u>	<u>2.84</u>	<u>991</u>	<u>3.14</u>	<u>1038</u>	<u>3.45</u>	<u>1082</u>	<u>3.75</u>	<u>1126</u>	<u>4.06</u>	<u>1167</u>	<u>4.38</u>
	6,000	<u>974</u>	<u>3.36</u>	<u>1022</u>	<u>3.69</u>	<u>1067</u>	<u>4.01</u>	<u>1111</u>	<u>4.34</u>	<u>1153</u>	<u>4.67</u>	<u>1193</u>	<u>5.00</u>
	6,800	<u>1015</u>	<u>4.05</u>	<u>1061</u>	<u>4.40</u>	<u>1104</u>	<u>4.75</u>	<u>1146</u>	<u>5.10</u>	<u>1187</u>	<u>5.46</u>	—	—
	7,500	<u>1054</u>	<u>4.75</u>	<u>1098</u>	<u>5.12</u>	<u>1140</u>	<u>5.49</u>	<u>1181</u>	<u>5.86</u>	—	—	—	—
BAC 240/245	6,000	<u>950</u>	<u>3.21</u>	<u>999</u>	<u>3.53</u>	<u>1045</u>	<u>3.85</u>	<u>1089</u>	<u>4.17</u>	<u>1131</u>	<u>4.50</u>	<u>1172</u>	<u>4.83</u>
	7,000	<u>996</u>	<u>4.02</u>	<u>1042</u>	<u>4.37</u>	<u>1086</u>	<u>4.72</u>	<u>1129</u>	<u>5.07</u>	<u>1169</u>	<u>5.43</u>	—	—
	8,000	<u>1047</u>	<u>4.99</u>	<u>1091</u>	<u>5.37</u>	<u>1133</u>	<u>5.75</u>	<u>1173</u>	<u>6.13</u>	—	—	—	—
	9,000	<u>1102</u>	<u>6.13</u>	<u>1143</u>	<u>6.54</u>	<u>1183</u>	<u>6.96</u>	—	—	—	—	—	—
	10,000	<u>1160</u>	<u>7.46</u>	<u>1200</u>	<u>7.91</u>	—	—	—	—	—	—	—	—

LEGEND

Bhp — Brake Horsepower Input to Fan

ESP — External Static Pressure

Bold indicates field-supplied drive is required.

Plain type indicates standard motor and standard drive.

Underline indicates a different motor and drive combination other than the standard motor and standard drive combination is required. Refer to fan motor and drive tables, pages 33-36, to complete selection.

NOTES:

- Fan performance is based on deductions for wet coil, clean 2-in. filters, and unit casing. See table at right for factory-supplied filter pressure drop.

Factory Supplied Filter Pressure Drop _ English

UNIT	AIRFLOW (Cfm)	PRESSURE DROP (in. wg)
BAC 075	1,800	0.05
	2,400	0.08
	3,000	0.11
BAC BHC 090	2,250	0.07
	3,000	0.11
	3,750	0.15
BAC BHC 120	3,000	0.11
	4,000	0.17
	5,000	0.23
BAC 150	3,750	0.06
	5,000	0.10
	6,250	0.13
BAC BHC 180	4,500	0.08
	6,000	0.12
	7,500	0.17
BAC 240/245	6,000	0.12
	8,000	0.19
	10,000	0.26

FAN PERFORMANCE DATA — 0-300 Pa ESP — 60 Hz, SI

UNIT	AIRFLOW (L/s)	EXTERNAL STATIC PRESSURE (Pa)													
		0		50		100		150		200		250		300	
		r/s	kW	r/s	kW	r/s	kW	r/s	kW	r/s	kW	r/s	kW	r/s	kW
BAC 075	850	5.34	0.17	7.38	0.25	8.91	0.32	10.20	0.39	<u>11.30</u>	<u>0.46</u>	<u>12.30</u>	<u>0.53</u>	<u>13.30</u>	<u>0.60</u>
	1000	6.28	0.24	8.10	0.32	9.53	0.40	10.80	0.48	<u>11.80</u>	<u>0.55</u>	<u>12.80</u>	<u>0.63</u>	<u>13.70</u>	<u>0.70</u>
	1150	7.22	0.33	8.86	0.41	10.20	0.50	<u>11.40</u>	<u>0.58</u>	<u>12.40</u>	<u>0.66</u>	<u>13.40</u>	<u>0.73</u>	<u>14.20</u>	<u>0.81</u>
	1300	8.17	0.43	9.64	0.52	10.90	0.61	<u>12.00</u>	<u>0.69</u>	<u>13.00</u>	<u>0.77</u>	<u>13.90</u>	<u>0.85</u>	<u>14.80</u>	<u>0.93</u>
	1450	9.11	0.55	10.50	0.64	<u>11.60</u>	<u>0.73</u>	<u>12.70</u>	<u>0.82</u>	<u>13.60</u>	<u>0.91</u>	<u>14.50</u>	<u>0.99</u>	<u>15.40</u>	<u>1.07</u>
BAC BHC 090	1000	5.63	0.22	7.61	0.30	9.11	0.38	10.40	0.45	11.50	0.53	<u>12.50</u>	<u>0.61</u>	<u>13.40</u>	<u>0.68</u>
	1200	6.76	0.32	8.49	0.41	9.88	0.50	11.10	0.57	12.10	0.66	<u>13.10</u>	<u>0.74</u>	<u>14.00</u>	<u>0.82</u>
	1400	7.89	0.46	9.42	0.55	10.70	0.64	11.80	0.72	<u>12.80</u>	<u>0.81</u>	<u>13.80</u>	<u>0.89</u>	<u>14.60</u>	<u>0.97</u>
	1600	9.01	0.62	10.40	0.71	11.60	0.80	<u>12.60</u>	<u>0.89</u>	<u>13.60</u>	<u>0.98</u>	<u>14.50</u>	<u>1.07</u>	<u>15.30</u>	<u>1.16</u>
	1800	10.10	0.80	11.40	0.90	<u>12.50</u>	<u>0.10</u>	<u>13.50</u>	<u>1.09</u>	<u>14.40</u>	<u>1.18</u>	<u>15.20</u>	<u>1.27</u>	<u>16.00</u>	<u>1.36</u>
BAC 120	1450	7.58	0.46	9.18	0.56	10.50	0.65	11.60	0.73	12.70	0.82	13.60	0.90	<u>14.50</u>	<u>0.99</u>
	1670	8.73	0.63	10.20	0.73	11.40	0.83	12.50	0.92	13.40	1.01	14.30	1.10	<u>15.20</u>	<u>1.18</u>
	1900	9.93	0.84	11.20	0.95	12.30	1.05	13.30	1.14	14.30	1.24	<u>15.10</u>	<u>1.33</u>	<u>15.90</u>	<u>1.42</u>
	2120	11.10	1.08	12.20	1.18	13.30	1.29	14.20	1.39	<u>15.10</u>	<u>1.48</u>	<u>15.90</u>	<u>1.58</u>	<u>16.70</u>	<u>1.68</u>
	2350	12.30	1.36	13.30	1.17	14.30	1.57	<u>15.20</u>	<u>1.68</u>	<u>16.00</u>	<u>1.78</u>	<u>16.80</u>	<u>1.88</u>	<u>17.60</u>	<u>1.98</u>
BHC 120	1450	8.04	0.49	9.57	0.58	10.90	0.67	12.00	0.76	13.00	0.85	13.90	0.93	<u>14.80</u>	<u>1.02</u>
	1670	9.26	0.67	10.60	0.77	11.80	0.86	12.90	0.95	13.80	1.04	<u>14.70</u>	<u>1.13</u>	<u>15.50</u>	<u>1.22</u>
	1900	10.50	0.89	11.80	0.99	12.80	1.09	13.80	1.19	<u>14.70</u>	<u>1.28</u>	<u>15.60</u>	<u>1.38</u>	<u>16.40</u>	<u>1.47</u>
	2120	11.80	1.14	12.90	1.24	13.90	1.35	<u>14.80</u>	<u>1.45</u>	<u>15.60</u>	<u>1.55</u>	<u>16.40</u>	<u>1.64</u>	<u>17.20</u>	<u>1.74</u>
	2350	13.00	1.43	14.00	1.54	<u>15.00</u>	<u>1.65</u>	<u>15.80</u>	<u>1.75</u>	<u>16.60</u>	<u>1.85</u>	<u>17.40</u>	<u>1.95</u>	<u>18.10</u>	<u>2.05</u>
BAC 150	1750	5.99	0.27	7.88	0.43	9.41	0.59	10.70	0.75	11.90	0.92	<u>13.00</u>	<u>1.08</u>	<u>14.00</u>	<u>1.25</u>
	2050	7.01	0.41	8.68	0.60	10.10	0.78	11.30	0.96	<u>12.40</u>	<u>1.14</u>	<u>13.50</u>	<u>1.33</u>	<u>14.40</u>	<u>1.51</u>
	2350	8.04	0.60	9.53	0.81	10.80	1.01	12.00	1.21	<u>13.00</u>	<u>1.41</u>	<u>14.00</u>	<u>1.61</u>	<u>14.90</u>	<u>1.82</u>
	2650	9.07	0.84	10.40	1.06	11.60	1.28	<u>12.70</u>	<u>1.50</u>	<u>13.70</u>	<u>1.72</u>	<u>14.60</u>	<u>1.94</u>	<u>15.50</u>	<u>2.16</u>
	2950	10.10	1.13	11.30	1.37	<u>12.40</u>	<u>1.61</u>	<u>13.40</u>	<u>1.85</u>	<u>14.40</u>	<u>2.08</u>	<u>15.30</u>	<u>2.32</u>	<u>16.10</u>	<u>2.56</u>
BAC 180	2100	6.43	0.37	8.19	0.55	9.65	0.73	10.90	0.92	12.10	1.11	<u>13.10</u>	<u>1.30</u>	<u>14.10</u>	<u>1.50</u>
	2450	7.51	0.57	9.06	0.77	10.40	0.97	11.60	1.18	<u>12.70</u>	<u>1.39</u>	<u>13.70</u>	<u>1.60</u>	<u>14.60</u>	<u>1.81</u>
	2800	8.58	0.82	9.96	1.05	11.20	1.27	<u>12.30</u>	<u>1.49</u>	<u>13.30</u>	<u>1.72</u>	<u>14.30</u>	<u>1.95</u>	<u>15.10</u>	<u>2.18</u>
	3150	9.65	1.14	10.90	1.38	12.00	1.63	<u>13.10</u>	<u>1.87</u>	<u>14.00</u>	<u>2.12</u>	<u>14.90</u>	<u>2.36</u>	<u>15.80</u>	<u>2.61</u>
	3500	10.70	1.52	11.90	1.78	<u>12.90</u>	<u>2.05</u>	<u>13.90</u>	<u>2.31</u>	<u>14.80</u>	<u>2.58</u>	<u>15.60</u>	<u>2.84</u>	<u>16.40</u>	<u>3.11</u>
BHC 180	2100	6.65	0.39	8.39	0.58	9.83	0.76	11.10	0.95	<u>12.20</u>	<u>1.13</u>	<u>13.30</u>	<u>1.31</u>	<u>14.20</u>	<u>1.50</u>
	2450	7.76	0.60	9.30	0.81	10.60	1.01	11.80	1.22	<u>12.90</u>	<u>1.43</u>	<u>13.80</u>	<u>1.63</u>	<u>14.80</u>	<u>1.84</u>
	2800	8.87	0.86	10.20	1.09	11.50	1.32	<u>12.50</u>	<u>1.55</u>	<u>13.60</u>	<u>1.78</u>	<u>14.50</u>	<u>2.01</u>	<u>15.40</u>	<u>2.24</u>
	3150	9.98	1.19	11.20	1.44	<u>12.30</u>	<u>1.70</u>	<u>13.40</u>	<u>1.95</u>	<u>14.30</u>	<u>2.20</u>	<u>15.20</u>	<u>2.45</u>	<u>16.00</u>	<u>2.70</u>
	3500	11.10	1.59	<u>12.20</u>	<u>1.86</u>	<u>13.20</u>	<u>2.14</u>	<u>14.20</u>	<u>2.41</u>	<u>15.10</u>	<u>2.68</u>	<u>15.90</u>	<u>2.95</u>	<u>16.70</u>	<u>3.22</u>
BAC 240/245	2900	8.58	0.86	9.96	1.09	11.20	1.32	12.30	1.55	13.30	1.78	14.20	2.01	<u>15.10</u>	<u>2.25</u>
	3350	9.91	1.28	11.10	1.53	12.20	1.79	13.20	2.04	14.20	2.30	<u>15.10</u>	<u>2.55</u>	<u>15.90</u>	<u>2.81</u>
	3800	11.30	1.81	12.30	2.09	13.30	2.37	<u>14.30</u>	<u>2.64</u>	<u>15.10</u>	<u>2.93</u>	<u>16.00</u>	<u>3.21</u>	<u>16.80</u>	<u>3.49</u>
	4250	12.60	2.46	13.60	2.76	<u>14.50</u>	<u>3.07</u>	<u>15.30</u>	<u>3.37</u>	<u>16.10</u>	<u>3.67</u>	<u>16.90</u>	<u>3.98</u>	<u>17.70</u>	<u>4.28</u>
	4700	13.90	3.24	<u>14.80</u>	<u>3.57</u>	<u>15.60</u>	<u>3.90</u>	<u>16.40</u>	<u>4.22</u>	<u>17.20</u>	<u>4.55</u>	<u>17.90</u>	<u>4.88</u>	<u>18.60</u>	<u>5.21</u>

See Legend and Notes on page 27.

FAN PERFORMANCE DATA — 350-600 Pa ESP — 60 Hz, SI

UNIT	AIR-FLOW (L/s)	EXTERNAL STATIC PRESSURE (Pa)											
		350		400		450		500		550		600	
		r/s	kW	r/s	kW	r/s	kW	r/s	kW	r/s	kW	r/s	kW
BAC 075	850	<u>14.10</u>	<u>0.67</u>	<u>15.00</u>	<u>0.74</u>	<u>15.70</u>	<u>0.81</u>	<u>16.50</u>	<u>0.87</u>	<u>17.20</u>	<u>0.94</u>	—	—
	1000	<u>14.60</u>	<u>0.77</u>	<u>15.40</u>	<u>0.84</u>	<u>16.10</u>	<u>0.91</u>	<u>16.90</u>	<u>0.98</u>	<u>17.60</u>	<u>1.06</u>	—	—
	1150	<u>15.10</u>	<u>0.88</u>	<u>15.90</u>	<u>0.96</u>	<u>16.60</u>	<u>1.03</u>	<u>17.30</u>	<u>1.11</u>	<u>18.00</u>	<u>1.18</u>	—	—
	1300	<u>15.60</u>	<u>1.01</u>	<u>16.40</u>	<u>1.09</u>	<u>17.10</u>	<u>1.17</u>	<u>17.80</u>	<u>1.25</u>	18.40	1.32	—	—
	1450	<u>16.10</u>	<u>1.15</u>	<u>16.90</u>	<u>1.24</u>	<u>17.60</u>	<u>1.32</u>	18.30	1.40	18.90	1.48	—	—
BAC BHC 090	1000	<u>14.30</u>	<u>0.76</u>	<u>15.10</u>	<u>0.83</u>	<u>15.80</u>	<u>0.91</u>	<u>16.60</u>	<u>0.99</u>	<u>17.30</u>	<u>1.06</u>	—	—
	1200	<u>14.80</u>	<u>0.90</u>	<u>15.60</u>	<u>0.98</u>	<u>16.40</u>	<u>1.05</u>	<u>17.10</u>	<u>1.13</u>	<u>17.80</u>	<u>1.21</u>	—	—
	1400	<u>15.40</u>	<u>1.06</u>	<u>16.20</u>	<u>1.14</u>	<u>16.90</u>	<u>1.22</u>	<u>17.60</u>	<u>1.30</u>	<u>18.30</u>	<u>1.39</u>	—	—
	1600	<u>16.10</u>	<u>1.24</u>	<u>16.80</u>	<u>1.33</u>	<u>17.50</u>	<u>1.41</u>	<u>18.20</u>	<u>1.50</u>	<u>18.90</u>	<u>1.58</u>	—	—
BAC 120	1450	<u>15.30</u>	<u>1.07</u>	<u>16.10</u>	<u>1.15</u>	<u>16.80</u>	<u>1.24</u>	<u>17.50</u>	<u>1.32</u>	<u>18.20</u>	<u>1.40</u>	<u>18.80</u>	<u>1.48</u>
	1670	<u>16.00</u>	<u>1.27</u>	<u>16.70</u>	<u>1.36</u>	<u>17.40</u>	<u>1.44</u>	<u>18.10</u>	<u>1.53</u>	<u>18.80</u>	<u>1.62</u>	<u>19.40</u>	<u>1.70</u>
	1900	<u>16.70</u>	<u>1.51</u>	<u>17.40</u>	<u>1.60</u>	<u>18.10</u>	<u>1.69</u>	<u>18.80</u>	<u>1.78</u>	<u>19.40</u>	<u>1.87</u>	—	—
	2120	<u>17.50</u>	<u>1.77</u>	<u>18.20</u>	<u>1.86</u>	<u>18.80</u>	<u>1.96</u>	<u>19.50</u>	<u>2.05</u>	—	—	—	—
	2350	<u>18.30</u>	<u>2.07</u>	<u>19.00</u>	<u>2.17</u>	<u>19.60</u>	<u>2.27</u>	—	—	—	—	—	—
BHC 120	1450	<u>15.60</u>	<u>1.10</u>	<u>16.30</u>	<u>1.18</u>	<u>17.10</u>	<u>1.27</u>	<u>17.80</u>	<u>1.35</u>	<u>18.40</u>	<u>1.43</u>	<u>19.10</u>	<u>1.52</u>
	1670	<u>16.30</u>	<u>1.31</u>	<u>17.00</u>	<u>1.40</u>	<u>17.80</u>	<u>1.48</u>	<u>18.40</u>	<u>1.57</u>	<u>19.10</u>	<u>1.66</u>	<u>19.70</u>	<u>1.74</u>
	1900	<u>17.10</u>	<u>1.56</u>	<u>17.80</u>	<u>1.65</u>	<u>18.50</u>	<u>1.74</u>	<u>19.20</u>	<u>1.83</u>	<u>19.80</u>	<u>1.92</u>	—	—
	2120	<u>17.90</u>	<u>1.83</u>	<u>18.60</u>	<u>1.93</u>	<u>19.30</u>	<u>2.02</u>	<u>19.90</u>	<u>2.11</u>	—	—	—	—
	2350	<u>18.80</u>	<u>2.15</u>	<u>19.50</u>	<u>2.25</u>	—	—	—	—	—	—	—	—
BAC 150	1750	<u>14.90</u>	<u>1.42</u>	<u>15.80</u>	<u>1.58</u>	<u>16.60</u>	<u>1.75</u>	<u>17.40</u>	<u>1.93</u>	<u>18.20</u>	<u>2.10</u>	—	—
	2050	<u>15.30</u>	<u>1.70</u>	<u>16.20</u>	<u>1.88</u>	<u>17.00</u>	<u>2.07</u>	<u>17.80</u>	<u>2.26</u>	18.50	2.45	—	—
	2350	<u>15.80</u>	<u>2.02</u>	<u>16.60</u>	<u>2.22</u>	<u>17.40</u>	<u>2.43</u>	<u>18.20</u>	<u>2.64</u>	18.90	2.84	—	—
	2650	<u>16.30</u>	<u>2.39</u>	<u>17.10</u>	<u>2.61</u>	<u>17.90</u>	<u>2.83</u>	18.60	3.06	<u>19.30</u>	<u>3.28</u>	—	—
	2950	<u>16.90</u>	<u>2.80</u>	<u>17.70</u>	<u>3.04</u>	<u>18.40</u>	<u>3.28</u>	<u>19.10</u>	<u>3.53</u>	<u>19.80</u>	<u>3.77</u>	—	—
BAC 180	2100	<u>15.00</u>	<u>1.70</u>	<u>15.80</u>	<u>1.90</u>	<u>16.70</u>	<u>2.11</u>	<u>17.40</u>	<u>2.32</u>	<u>18.20</u>	<u>2.53</u>	<u>18.90</u>	<u>2.74</u>
	2450	<u>15.50</u>	<u>2.03</u>	<u>16.30</u>	<u>2.25</u>	<u>17.10</u>	<u>2.47</u>	<u>17.80</u>	<u>2.70</u>	<u>18.60</u>	<u>2.93</u>	<u>19.30</u>	<u>3.16</u>
	2800	<u>16.00</u>	<u>2.42</u>	<u>16.80</u>	<u>2.66</u>	<u>17.60</u>	<u>2.90</u>	<u>18.30</u>	<u>3.14</u>	<u>19.00</u>	<u>3.38</u>	<u>19.70</u>	<u>3.63</u>
	3150	<u>16.60</u>	<u>2.87</u>	<u>17.40</u>	<u>3.12</u>	<u>18.10</u>	<u>3.38</u>	<u>18.80</u>	<u>3.64</u>	<u>19.50</u>	<u>3.90</u>	—	—
	3500	<u>17.20</u>	<u>3.38</u>	<u>18.00</u>	<u>3.65</u>	<u>18.70</u>	<u>3.93</u>	<u>19.40</u>	<u>4.20</u>	—	—	—	—
BHC 180	2100	<u>15.10</u>	<u>1.68</u>	<u>16.00</u>	<u>1.87</u>	<u>16.80</u>	<u>2.06</u>	<u>17.50</u>	<u>2.24</u>	<u>18.30</u>	<u>2.43</u>	<u>19.00</u>	<u>2.62</u>
	2450	<u>15.60</u>	<u>2.05</u>	<u>16.40</u>	<u>2.25</u>	<u>17.20</u>	<u>2.46</u>	<u>18.00</u>	<u>2.67</u>	<u>18.70</u>	<u>2.88</u>	<u>19.40</u>	<u>3.09</u>
	2800	<u>16.20</u>	<u>2.47</u>	<u>17.00</u>	<u>2.69</u>	<u>17.80</u>	<u>2.92</u>	<u>18.50</u>	<u>3.15</u>	<u>19.20</u>	<u>3.38</u>	<u>19.80</u>	<u>3.61</u>
	3150	<u>16.80</u>	<u>2.95</u>	<u>17.60</u>	<u>3.19</u>	<u>18.30</u>	<u>3.44</u>	<u>19.00</u>	<u>3.69</u>	<u>19.70</u>	<u>3.94</u>	—	—
	3500	<u>17.50</u>	<u>3.49</u>	<u>18.20</u>	<u>3.76</u>	<u>19.00</u>	<u>4.03</u>	<u>19.60</u>	<u>4.30</u>	—	—	—	—
BAC 240/245	2900	<u>16.00</u>	<u>2.49</u>	<u>16.80</u>	<u>2.73</u>	<u>17.50</u>	<u>2.97</u>	<u>18.30</u>	<u>3.22</u>	<u>19.00</u>	<u>3.47</u>	<u>19.70</u>	<u>3.72</u>
	3350	<u>16.70</u>	<u>3.08</u>	<u>17.50</u>	<u>3.34</u>	<u>18.20</u>	<u>3.61</u>	<u>18.90</u>	<u>3.87</u>	<u>19.60</u>	<u>4.14</u>	—	—
	3800	<u>17.50</u>	<u>3.77</u>	<u>18.20</u>	<u>4.06</u>	<u>18.90</u>	<u>4.35</u>	<u>19.60</u>	<u>4.64</u>	—	—	—	—
	4250	<u>18.40</u>	<u>4.59</u>	<u>19.10</u>	<u>4.90</u>	<u>19.80</u>	<u>5.21</u>	—	—	—	—	—	—
	4700	<u>19.30</u>	<u>5.54</u>	<u>20.00</u>	<u>5.87</u>	—	—	—	—	—	—	—	—

LEGEND

ESP — External Static Pressure

Bold indicates field-supplied drive is required.

Plain type indicates standard motor and standard drive.

Underline indicates a different motor and drive combination other than the standard motor and standard drive combination is required. Refer to fan motor and drive tables, pages 33-36, to complete the selection.

NOTES:

- Fan performance is based on deductions for wet coil, clean 51-mm filters, and unit casing. See table at right for factory-supplied filter pressure drop.

FACTORY-SUPPLIED FILTER PRESSURE DROP — SI

UNIT	AIRFLOW (L/s)	PRESSURE DROP (Pa)
BAC 075	850	13
	1150	20
	1450	28
BAC BHC 090	1000	17
	1400	27
	1800	38
BAC BHC 012	1450	28
	1900	42
	2350	56
BAC 150	1750	15
	2350	24
	2950	33
BAC BHC 180	2100	20
	2800	30
	3500	42
BAC 240/245	2900	32
	3800	47
	4700	64

**ACCESSORY PLENUM AIR THROW DATA — ENGLISH
(Ft)**

UNIT	AIRFLOW (Cfm)	VANE DEFLECTION		
		Straight	21-1/2°	45°
BAC 075	2,400	39	33	24
BAC BHC 090	3,000	45	38	28
BAC BHC 120	4,000	55	46	33
BAC 150	5,000	45	38	28
BAC BHC 180	6,000	50	43	31
BAC 240/245	8,000	60	51	37

NOTE: Throw distances shown are for 75 fpm terminal velocity. Use the following multipliers to determine throw values for other terminal velocities.

TERMINAL VELOCITY (Fpm)	THROW FACTOR
50	X 1.50
100	X 0.75
150	X 0.50

**ACCESSORY PLENUM AIR THROW DATA — SI
(m)**

UNIT	AIRFLOW (L/s)	VANE DEFLECTION		
		Straight	21-1/2°	45°
BAC 075	1150	11.71	9.91	7.20
BAC BHC 090	1400	13.87	11.71	8.63
BAC BHC 120	1900	16.65	13.93	9.99
BAC 150	2350	13.77	11.63	8.57
BAC BHC 180	2800	15.41	13.25	9.55
BAC 240/245	3800	18.17	15.44	11.20

NOTE: Throw distances shown are for 0.381 m/sec terminal velocity. Use the following multipliers to determine throw values for other terminal velocities.

TERMINAL VELOCITY (m/sec)	THROW FACTOR
0.254	X 1.50
0.508	X 0.75
0.762	X 0.50

ACCESSORY PRESSURE DROP — ENGLISH (in. wg)

UNIT	AIRFLOW (Cfm)	DISCHARGE PLENUM	RETURN AIR GRILLE	HEATING COILS			ECONOMIZER
				Hot Water	Steam	Electric	
BAC 075	1,800	0.06	0.01	0.10	0.10	0.04	0.05
	2,400	0.10	0.01	0.16	0.16	0.06	0.07
	3,000	0.14	0.02	0.23	0.23	0.10	0.09
BAC BHC 090	2,250	0.09	0.01	0.15	0.15	0.06	0.06
	3,000	0.14	0.02	0.23	0.23	0.10	0.09
	3,750	0.21	0.03	0.35	0.35	0.15	0.15
BAC BHC 120	3,000	0.14	0.02	0.23	0.23	0.10	0.09
	4,000	0.22	0.04	0.37	0.37	0.17	0.17
	5,000	0.32	0.06	0.53	0.53	0.26	0.28
BAC 150	3,750	0.07	0.01	0.11	0.11	0.04	0.05
	5,000	0.12	0.02	0.17	0.17	0.07	0.07
	6,250	0.17	0.02	0.25	0.25	0.11	0.11
BAC BHC 180	4,500	0.10	0.01	0.15	0.15	0.06	0.06
	6,000	0.16	0.02	0.23	0.23	0.10	0.09
	7,500	0.23	0.03	0.33	0.33	0.15	0.15
BAC 240/245	6,000	0.16	0.02	0.23	0.23	0.10	0.09
	8,000	0.26	0.04	0.37	0.37	0.17	0.17
	10,000	0.37	0.06	0.53	0.53	0.26	0.28

ACCESSORY PRESSURE DROP — SI (Pa)

UNIT	AIRFLOW (L/s)	DISCHARGE PLENUM	RETURN AIR GRILLE	HEATING COILS			ECONOMIZER
				Hot Water	Steam	Electric	
BAC 075	850	15	2	25	25	9	12
	1150	25	3	41	41	16	18
	1450	36	5	60	60	26	23
BAC BHC 090	1000	20	2	33	33	12	13
	1400	34	5	57	57	24	22
	1800	51	8	85	85	39	39
BAC BHC 120	1450	36	5	60	60	26	23
	1900	56	10	93	93	43	43
	2350	79	15	132	132	65	69
BAC 150	1750	18	2	26	26	10	12
	2350	29	5	43	43	17	17
	2950	43	5	62	62	26	27
BAC BHC 180	2100	24	2	36	36	14	15
	2800	39	5	57	57	24	22
	3500	56	7	82	82	37	37
BAC 240/245	2900	41	5	60	60	26	23
	3800	64	10	93	93	43	43
	4700	91	15	132	132	65	69

STANDARD MOTORS

See Legend and Notes on page 30.

UNIT	V*-PH-Hz	VOLTAGE LIMITS	FAN MOTOR		POWER SUPPLY	
			Hp (kW)	FLA	Minimum Circuit Amps	MOCP
BAC 075	208/230-3-60	187-253	2.4 (1.79)	5.2	6.5	15
	460-3-60	414-506	2.4 (1.79)	2.6	3.3	15
	575-3-60	518-632	1.0 (0.75)	1.4	1.8	15
BAC BHC 090	208/230-3-60	187-253	2.4 (1.79)	5.2	6.5	15
	460-3-60	414-506	2.4 (1.79)	2.6	3.3	15
	575-3-60	518-632	2.0 (1.49)	2.3	2.9	15
BAC BHC 120	208/230-3-60	187-253	2.4 (1.79)	5.2	6.5	15
	460-3-60	414-506	2.4 (1.79)	2.6	3.3	15
	575-3-60	518-632	2.0 (1.49)	2.3	2.9	15
BAC 150	208/230-3-60	187-253	2.9 (2.16)	7.5	9.4	15
	460-3-60	414-506	2.9 (2.16)	3.4	4.3	15
	575-3-60	518-632	3.0 (2.24)	3.8	4.8	15
BAC BHC 180	208/230-3-60	187-253	3.7 (2.76)	10.2	12.8	20
	460-3-60	414-506	3.7 (2.76)	4.8	6.0	15
	575-3-60	518-632	3.0 (2.24)	3.8	4.8	15
BAC 240/245	208/230-3-60	187-253	5.0 (3.73)	14.6/12.8	18.3/16.0	30/25
	460-3-60	414-506	5.0 (3.73)	6.4	8.0	15
	575-3-60	518-632	5.0 (3.73)	5.1	6.4	15

ALTERNATE MOTORS

See Legend and Notes on page 30.

UNIT	V*-PH-Hz	VOLTAGE LIMITS	FAN MOTOR		POWER SUPPLY	
			Hp (kW)	FLA	Minimum Circuit Amps	MOCP
BAC 075	208/230-3-60	187-253	2.9 (2.16)	7.5	9.4	15
	460-3-60	414-506	2.9 (2.16)	3.4	4.3	15
	575-3-60	518-632	2.0 (1.49)	2.3	2.9	15
BAC BHC 090	208/230-3-60	187-253	2.9 (2.16)	7.5	9.4	15
	460-3-60	414-506	2.9 (2.16)	3.4	4.3	15
	575-3-60	518-632	3.0 (2.24)	3.8	4.8	15
BAC BHC 120	208/230-3-60	187-253	3.7 (2.76)	10.2	12.8	20
	460-3-60	414-506	3.7 (2.76)	4.8	6.0	15
	575-3-60	518-632	3.0 (2.24)	3.8	4.8	15
BAC 150	208/230-3-60	187-253	3.7 (2.76)	10.2	12.7	20
	460-3-60	414-506	3.7 (2.76)	4.8	6.0	15
	575-3-60	518-632	5.0 (3.73)	5.1	4.8	15
BAC BHC 180	208/230-3-60	187-253	5.0 (3.73)	14.6/12.8	18.3/16.0	30/25
	460-3-60	414-506	5.0 (3.73)	6.4	8.0	15
	575-3-60	518-632	5.0 (3.73)	5.1	6.4	15
BAC 240/245	208/230-3-60	187-253	7.5 (5.59)	21.5/19.4	26.9/24.3	45/40
	460-3-60	414-506	7.5 (5.59)	9.7	12.1	20
	575-3-60	518-632	7.5 (5.59)	7.8	9.8	15

LEGEND

FLA — Full Load Amps

MOCP — Maximum Overcurrent Protection

*Motors are designed for satisfactory operation within 10% of nominal voltages shown. Voltages should not exceed the limits shown in the Voltage Limits column.

NOTES:

1. Minimum circuit amps (MCA) and MOCP values are calculated in accordance with NEC (National Electrical Code) (U.S.A. standard), Article 440.
2. Motor FLA values are established in accordance with UL (Underwriters' Laboratories) Standard 1995 (U.S.A. standard).
3. **Unbalanced 3-Phase Supply Voltage**
Never operate a motor where a phase imbalance in supply voltage is greater than 2%. Use the following formula to determine the % of voltage imbalance.

% Voltage Imbalance =

$$100 \times \frac{\text{max voltage deviation from average voltage}}{\text{average voltage}}$$

Example supply voltage is 460-3-60

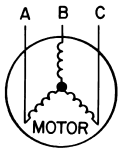

AB = 393 v

BC = 403 v

AC = 396 v

$$\text{Average voltage} = \frac{393 + 403 + 396}{3}$$

$$= \frac{1192}{3}$$

$$= 397$$

Determine maximum deviation from average voltage

(AB) $397 - 393 = 4\text{v}$

(BC) $403 - 397 = 6\text{v}$

(AC) $397 - 396 = 1\text{v}$

Maximum deviation is 6 v

Determine percent of voltage imbalance.

$$\% \text{ of Voltage Imbalance} = 100 \times \frac{6}{397}$$

$$= 1.5\%$$

The amount of phase imbalance is satisfactory as it is below the maximum allowable 2 %.

Important: If the supply voltage phase imbalance is more than 2%, contact your local electric utility company.

TABLE 1 - ELECTRIC HEAT DATA

Heater Part Number	Unit Size (Tons)	V-PH-HZ	FAN MOTOR			ELECTRIC HEATERS						
			Hp	kW	FLA	Nominal Capacity (kW)	Actual Capacity (kW)			FLA	MCA*	MOCP*
							Stage 1	Stage 2	Total			
AAHC05AHA	6 to 10	208-3-60	2.4	1.79	5.2	5	3.8	-	3.8	10.4	19.5	20
			2.9	2.16	7.5	5	3.8	-	3.8	10.4	22.4	25
			3.7	2.76	10.2	5	3.8	-	3.8	10.4	25.8	30
		240-3-60	2.4	1.79	5.2	5	5.0	-	5.0	12.0	21.5	25
			2.9	2.16	7.5	5	5.0	-	5.0	12.0	24.4	25
			3.7	2.76	10.2	5	5.0	-	5.0	12.0	27.8	30
AAHC05ALA	6 to 10	480-3-60	2.4	1.79	2.6	5	5.0	-	5.0	6.0	10.8	15
			2.9	2.16	3.4	5	5.0	-	5.0	6.0	11.8	15
			3.7	2.76	4.8	5	5.0	-	5.0	6.0	13.5	15
AAHC05ASA	6 to 10	575-3-60	1.0	0.75	1.4	5	5.0	-	5.0	5.0	8.0	15
			2.0	1.49	2.3	5	5.0	-	5.0	5.0	9.2	15
			3.0	2.24	3.8	5	5.0	-	5.0	5.0	11.0	15
AAHC10AHA	6 to 10	208-3-60	2.4	1.79	5.2	10	7.5	-	7.5	20.8	32.6	35
			2.9	2.16	7.5	10	7.5	-	7.5	20.8	35.4	40
			3.7	2.76	10.2	10	7.5	-	7.5	20.8	38.8	40
		240-3-60	2.4	1.79	5.2	10	10.0	-	10.0	24.1	36.6	40
			2.9	2.16	7.5	10	10.0	-	10.0	24.1	39.4	40
			3.7	2.76	10.2	10	10.0	-	10.0	24.1	42.8	50
AAHC10ALA	6 to 10	480-3-60	2.4	1.79	2.6	10	10.0	-	10.0	12.0	18.3	20
			2.9	2.16	3.4	10	10.0	-	10.0	12.0	19.3	20
			3.7	2.76	4.8	10	10.0	-	10.0	12.0	21.0	25
AAHC10ASA	6 to 10	575-3-60	1.0	0.75	1.4	10	10.0	-	10.0	10.0	14.3	15
			2.0	1.49	2.3	10	10.0	-	10.0	10.0	15.4	20
			3.0	2.24	3.8	10	10.0	-	10.0	10.0	17.3	20
AAHC15AHA	6 to 10	208-3-60	2.4	1.79	5.2	15	11.3	-	11.3	31.3	45.6	50
			2.9	2.16	7.5	15	11.3	-	11.3	31.3	48.5	50
			3.7	2.76	10.2	15	11.3	-	11.3	31.3	51.9	60
		240-3-60	2.4	1.79	5.2	15	15.0	-	15.0	36.1	58.9	60
			2.9	2.16	7.5	15	15.0	-	15.0	36.1	54.5	60
			3.7	2.76	10.2	15	15.0	-	15.0	36.1	57.9	60
AAHC15ALA	6 to 10	480-3-60	2.4	1.79	2.6	15	15.0	-	15.0	18.0	25.8	30
			2.9	2.16	3.4	15	15.0	-	15.0	18.0	26.8	30
			3.7	2.76	4.8	15	15.0	-	15.0	18.0	28.6	30
AAHC15ASA	6 to 10	575-3-60	1.0	0.75	1.4	15	15.0	-	15.0	15.1	20.6	25
			2.0	1.49	2.3	15	15.0	-	15.0	15.1	21.7	25
			3.0	2.24	3.8	15	15.0	-	15.0	15.1	23.6	25
AAHC25AHA	6 to 10	208-3-60	2.4	1.79	5.2	25	11.3	7.5	18.8	52.1	71.7	80
			2.9	2.16	7.5	25	11.3	7.5	18.8	52.1	74.5	80
			3.7	2.76	10.2	25	11.3	7.5	18.8	52.1	77.9	80
		240-3-60	2.4	1.79	5.2	25	15.0	10.0	25.0	60.1	81.7	90
			2.9	2.16	7.5	25	15.0	10.0	25.0	60.1	84.6	90
			3.7	2.76	10.2	25	15.0	10.0	25.0	60.1	87.9	90
AAHC25ALA	6 to 10	480-3-60	2.4	1.79	2.6	25	15.0	10.0	25.0	30.1	40.8	50
			2.9	2.16	3.4	25	15.0	10.0	25.0	30.1	41.8	50
			3.7	2.76	7.6	25	15.0	10.0	25.0	30.1	43.6	50
AAHC25ASA	6 to 10	575-3-60	1.0	0.75	1.4	25	15.0	10.0	25.0	25.1	33.1	35
			2.0	1.49	2.3	25	15.0	10.0	25.0	25.1	34.3	35
			3.0	2.24	3.8	25	15.0	10.0	25.0	25.1	36.1	40

SEE LEGEND ON PAGE 34

TABLE 1 - ELECTRIC HEAT DATA (Cont.)

Heater Part Number	Unit Size (Tons)	V-PH-HZ	FAN MOTOR			ELECTRIC HEATERS						
			Hp	kW	FLA	Nominal Capacity (kW)	Actual Capacity (kW)			FLA	MCA*	MOCP*
							Stage 1	Stage 2	Total			
AAHC35CHA	7-1/2 to 10	208-3-60	2.4	1.79	5.2	35	15.0	11.3	26.3	73.0	97.7	100
			2.9	2.16	7.5	35	15.0	11.3	26.3	73.0	100.6	110
			3.7	2.76	10.2	35	15.0	11.3	26.3	73.0	104.0	110
		240-3-60	2.4	1.79	5.2	35	20.0	15.0	35.0	84.2	111.7	125
			2.9	2.16	7.5	35	20.0	15.0	35.0	84.2	114.6	125
			3.7	2.76	10.2	35	20.0	15.0	35.0	84.2	118.0	125
AAHC35CLA	7-1/2 to 10	480-3-60	2.4	1.79	2.6	35	20.0	15.0	35.0	42.1	55.9	60
			2.9	2.16	3.4	35	20.0	15.0	35.0	42.1	56.9	60
			3.7	2.76	4.8	35	20.0	15.0	35.0	42.1	58.6	60
AAHC35CSA	7-1/2 to 10	575-3-60	2.0	1.49	2.3	35	20.0	15.0	35.0	35.1	46.8	50
			3.0	2.24	3.8	35	20.0	15.0	35.0	35.1	48.7	50
AAHC10BHA	12-1/2 to 20	208-3-60	2.9	2.16	7.5	10	7.5	-	7.5	20.8	35.4	40
			3.7	2.76	10.2	10	7.5	-	7.5	20.8	38.8	40
			5.0	3.73	15.3	10	7.5	-	7.5	20.8	45.1	50
		240-3-60	2.9	2.16	7.5	10	10.0	-	10.0	24.1	39.4	40
			3.7	2.76	10.2	10	10.0	-	10.0	24.1	42.8	50
			5.0	3.73	15.3	10	10.0	-	10.0	24.1	46.1	50
AAHC10BLA	12-1/2 to 20	480-3-60	2.9	2.16	3.4	10	10.0	-	10.0	12.0	19.3	20
			3.7	2.76	4.8	10	10.0	-	10.0	12.0	21.0	25
			5.0	3.73	6.4	10	10.0	-	10.0	12.0	23.0	25
AAHC10BSA	12-1/2 to 20	575-3-60	3.0	2.24	3.8	10	10.0	-	10.0	10.0	17.3	20
			5.0	3.73	5.1	10	10.0	-	10.0	10.0	19.6	20
AAHC20BHA	12-1/2 to 20	208-3-60	2.9	2.16	7.5	20	15.0	-	15.0	41.7	61.5	70
			3.7	2.76	10.2	20	15.0	-	15.0	41.7	65.4	70
			5.0	3.73	15.3	20	15.0	-	15.0	41.7	71.1	80
		240-3-60	2.9	2.16	7.5	20	20.0	-	20.0	48.1	69.5	70
			3.7	2.76	10.2	20	20.0	-	20.0	48.1	73.4	80
			5.0	3.73	15.3	20	20.0	-	20.0	48.1	76.1	80
AAHC20BLA	12-1/2 to 20	480-3-60	2.9	2.16	3.4	20	20.0	-	20.0	24.1	34.3	35
			3.7	2.76	4.8	20	20.0	-	20.0	24.1	36.1	40
			5.0	3.73	6.4	20	20.0	-	20.0	24.1	39.1	40
AAHC20BSA	12-1/2 to 20	575-3-60	3.0	2.24	3.8	20	20.0	-	20.0	20.1	29.9	30
			5.0	3.73	5.1	20	20.0	-	20.0	20.1	31.5	35
AAHC30BHA	12-1/2 to 20	208-3-60	2.9	2.16	7.5	30	15.0	7.5	22.5	62.5	87.5	90
			3.7	2.76	10.2	30	15.0	7.5	22.5	62.5	90.9	100
			5.0	3.73	15.3	30	15.0	7.5	22.5	62.5	97.2	100
		240-3-60	2.9	2.16	7.5	30	20.0	10.0	30.0	72.2	99.6	100
			3.7	2.76	10.2	30	20.0	10.0	30.0	72.2	103.0	110
			5.0	3.73	15.3	30	20.0	10.0	30.0	72.2	106.2	110
AAHC30BLA	12-1/2 to 20	480-3-60	2.9	2.16	3.4	30	20.0	10.0	30.0	36.1	49.4	50
			3.7	2.76	4.8	30	20.0	10.0	30.0	36.1	51.1	60
			5.0	3.73	6.4	30	20.0	10.0	30.0	36.1	53.1	60
AAHC30BSA	12-1/2 to 20	575-3-60	3.0	2.24	3.8	30	20.0	10.0	30.0	30.1	42.4	50
			5.0	3.73	5.1	30	20.0	10.0	30.0	30.1	44.0	50
AAHC50DHA	15 & 20	208-3-60	3.7	2.76	10.2	50	22.6	15.0	37.6	104.3	143.1	150
			5.0	3.73	15.3	50	22.6	15.0	37.6	104.3	149.5	150
		240-3-60	3.7	2.76	10.2	50	30.0	20.0	50.0	120.3	163.1	175
			5.0	3.73	15.3	50	30.0	20.0	50.0	120.3	166.4	175
AAHC50DLA	15 & 20	480-3-60	3.7	2.76	4.8	50	30.0	20.0	50.0	60.1	81.2	90
			5.0	3.73	6.4	50	30.0	20.0	50.0	60.1	83.2	90
AAHC50DSA	15 & 20	575-3-60	3.0	2.16	3.8	50	30.0	20.0	50.0	50.2	67.5	70
			5.0	3.73	5.1	50	30.0	20.0	50.0	50.2	69.1	70

SEE LEGEND ON PAGE 33

FLA - Full Load Amps, **Hp** - Horsepower, **MCA** - Minimum Circuit Ampacity, **MOCP** - Maximum Overcurrent Protection (Amps)

* Values shown are for single-point connection of electric heat accessory and air handler.

NOTES: 1. The following equation converts kW of heat energy to Btuh: kW x 3.412 = Btuh. 2. Heater contactor coils are 24v and require 8 va holding current. 3. Electric heaters are tested and ETL approved at max. total external static pressure of 1.9 wg. MCA and MOCP values apply to both standard and alternate factory supplied motors.

Heater Rating Voltage	ACTUAL HEATER VOLTAGE										
	200	208	230	240	400	440	460	480	550	575	600
240	0.694	0.751	0.918	1	-	-	-	-	-	-	-
480	-	-	-	-	0.694	0.84	0.918	1	-	-	-
575	-	-	-	-	-	-	-	-	0.915	1	1.089

FAN MOTOR DATA - Standard Motor - English

UNIT	BAC 075	BAC BHC 090	BAC BHC 120	BAC 150	BAC BHC 180	BAC 240
208/230-3-60 and 460-3-60						
Speed (rpm)	1725	1725	1725	1725	1725	1745
Hp	2.4	2.4	2.4	2.9	3.7	5.0
Frame (NEMA)	56Y	56Y	56Y	56Y	56Y	S184T
Shaft Dia (in.)	5/8	5/8	5/8	7/8	7/8	1 1/8
575-3-60						
Speed (rpm)	1725	1725	1725	1725	1725	1745
Hp	1.0	2.0	2.0	3.0	3.0	5.0
Frame (NEMA)	56	56HZ	56HZ	56HZ	56HZ	184T
Shaft Dia (in.)	5/8	7/8	7/8	7/8	7/8	1 1/8

LEGEND

NEMA — National Electrical Manufacturers Association (U.S.A.)

FAN MOTOR DATA - Alternate Motor - English

UNIT	BAC 075	BAC BHC 090	BAC BHC 120	BAC 150	BAC BHC 180	BAC 240/245
230-3-60 and 460-3-60						
Speed (rpm)	1725	1725	1725	1725	1725	1745
Hp	2.9	2.9	3.7	3.7	5.0	7.5
Frame (NEMA)	56Y	56Y	Y56Y	Y56Y	S184T	S213T
Shaft Dia (in.)	7/8	7/8	7/8	7/8	1 1/8	1 3/8
575-3-60						
Speed (rpm)	1725	1725	1725	1745	1745	1755
Hp	2.0	3.0	3.0	5.0	5.0	7.5
Frame (NEMA)	56HZ	56HZ	56HZ	184T	184T	S213T
Shaft Dia (in.)	7/8	7/8	7/8	1 1/8	1 1/8	1 3/8

LEGEND

NEMA — National Electrical Manufacturers Association (U.S.A.)

FAN MOTOR DATA - Standard Motor - SI

UNIT	BAC 075	BAC BHC 090	BAC BHC 120	BAC 150	BAC BHC 180	BAC 240/245
208/230-3-60 and 460-3-60						
Speed (r/s)	28.75	28.75	28.75	28.75	28.75	29.08
Shaft kW	1.79	1.79	1.79	2.16	2.76	3.73
Frame (NEMA)	56Y	56Y	56Y	56Y	56Y	S184T
Shaft Dia (mm)	15.9	15.9	15.9	22.2	22.2	28.6
575-3-60						
Speed(r/s)	28.75	28.75	28.75	28.75	28.75	29.08
Shaft kW	0.75	1.49	1.49	2.24	2.24	3.73
Frame (NEMA)	56	56HZ	56HZ	56HZ	56HZ	184T
Shaft Dia (mm)	15.9	22.2	22.2	22.2	22.2	28.6

LEGEND

NEMA — National Electrical Manufacturers Association (U.S.A.)

FAN MOTOR DATA - Alternate Motor - SI

UNIT	BAC 075	BAC BHC 090	BAC BHC 120	BAC 150	BAC BHC 180	BAC 240/245
208/230-3-60 and 460-3-60						
Speed(r/s)	28.75	28.75	28.75	28.75	29.08	29.08
Shaft kW	2.16	2.16	2.76	2.76	3.73	5.60
Frame (NEMA)	56Y	56Y	Y56Y	Y56Y	S184T	S213T
Shaft Dia (mm)	22.2	22.2	22.2	22.2	28.6	34.9
575-3-60						
Speed (r/s)	28.75	28.75	28.75	29.08	29.08	29.25
Shaft kW	1.50	2.24	2.24	3.73	3.73	5.60
Frame (NEMA)	56HZ	56HZ	56HZ	184T	184T	S213T
Shaft Dia (mm)	22.2	22.2	22.2	28.6	28.6	34.9

LEGEND

NEMA — National Electrical Manufacturers Association (U.S.A.)

MEDIUM-STATIC DRIVE DATA, 60 Hz — ENGLISH

UNIT	BAC 075	BHC 090*1B ¹	BAC BHC 090	BAC BHC 120	BAC 150	BAC BHC 180	BAC 240/245
MOTOR DRIVE							
Motor Pulley Pitch Diameter (in.)	3.4-4.4	2.8-3.8	3.4-4.4	3.4-4.4	3.4-4.4	3.7-4.7	4.3-5.3
Pulley Factory Setting Full Turns Open	2.5	2.5	2.5	2.5	2.5	3.0	3.0
FAN DRIVE							
Pulley Pitch Dia (in.)	8.8	8.8	8.0	8.0	8.2	8.6	9.4
Pulley Bore (in.)	1	1	1	1	1 ^{7/16}	1 ^{7/16}	1 ^{7/16}
Belt No. — Section	1—A	1—A	1—A	1—A	1—A	1—B	2—B
Belt Pitch (in.)	42.3	41.3	40.3	40.3	41.3	41.8	41.8
FAN SPEEDS (rpm)							
Factory Setting	764	647	841	841	820	842	881
Range	666-863	549-745	733-949	733-949	715-926	742-943	798-984
Max Allowable Speed (rpm)	1200	1200	1200	1200	1200	1200	1200
Change per 1/2 Turn of Moveable Motor Pulley Flange	19.7	19.6	21.6	21.6	21.1	16.7	15.3
MAX FULL TURNS FROM CLOSED POSITION							
	5	5	5	5	5	6	6
SHAFTS CENTER DISTANCE (in.)							
	10.44- 12.32	10.44- 12.32	10.44- 12.32	10.44- 12.32	10.44- 12.32	10.44- 12.32	9.16- 10.99

¹ Standard Motor, Standard Drive Only

HIGH-STATIC DRIVE DATA, 60 Hz — ENGLISH

UNIT	BAC 075	BAC BHC 090	BAC BHC 120	BAC 150	BAC BHC 180	BAC 240/245
MOTOR DRIVE						
Motor Pulley Pitch Diameter (in.)	3.4-4.4	3.4-4.4	3.4-4.4	3.7-4.7	4.3-5.3	4.3-5.3
Pulley Factory Setting Full Turns Open	2.5	2.5	2.5	3.0	3.0	3.0
FAN DRIVE						
Pulley Pitch Dia (in.)	7.0	6.0	6.0	7.4	7.9	7.4
Pulley Bore (in.)	1	1	1	1 ^{7/16}	1 ^{7/16}	1 ^{7/16}
Belt No. — Section	1—A	1—A	1—A	1—B	1—B	2—B
Belt Pitch (in.)	41.3	37.3	37.3	39.8	39.8	36.8
FAN SPEEDS (rpm)						
Factory Setting	961	1121	1121	979	1060	1118
Range	838- 1084	978- 1200†	978- 1200†	873- 1096	950- 1171	1014- 1200†
Max Allowable Speed (rpm)	1200	1200	1200	1200	1200	1200
Change per 1/2 Turn of Moveable Motor Pulley Flange	24.6	28.7	28.7	19.4	18.4	19.4
MAX FULL TURNS FROM CLOSED POSITION						
	5	5	5	6	6	6
SHAFTS CENTER DISTANCE (in.)						
	10.44- 12.32	10.44- 12.32	10.44- 12.32	10.44- 12.32*	9.16- 10.99	8.16- 10.02

†It is possible to adjust drive so that fan speed exceeds maximum allowable. DO NOT exceed 1200 rpm.

*575-v unit has a center distance of 9.16-10.99.

MEDIUM-STATIC DRIVE DATA, 60 Hz — SI

UNIT	BAC 075	BHC 090*1B ¹	BAC BHC 090	BAC BHC 120	BAC 150	BAC BHC 180	BAC 240/245
MOTOR DRIVE							
Motor Pulley Pitch Diameter (mm)	86.4-111.8	71.1-96.5	86.4-111.8	86.4-111.8	86.4-111.8	94.0-119.4	109.2-134.6
Pulley Factory Setting Full Turns Open	2.5	2.5	2.5	2.5	2.5	3.0	3.0
FAN DRIVE							
Pulley Pitch Dia (mm)	224	224	203	203	208	218	239
Pulley Bore (mm)	25.4	25.4	25.4	25.4	36.5	36.5	36.5
Belt No. — Section	1—A	1—A	1—A	1—A	1—A	1—B	2—B
Belt Pitch (mm)	1074	1049	1024	1024	1049	1062	1062
FAN SPEEDS (r/s)							
Factory Setting	12.7	10.8	14.0	14.0	13.7	14.0	14.7
Range	11.1-14.4	9.2-12.4	12.2-15.8	12.2-15.8	11.9-15.4	12.4-15.7	13.3-16.4
Max Allowable Speed (r/s)	20.0	20.0	20.0	20.0	20.0	20.0	20.0
Change per 1/2 Turn of Moveable Motor Pulley Flange	0.328	0.327	0.360	0.360	0.352	0.278	0.255
MAX FULL TURNS FROM CLOSED POSITION	5	5	5	5	6	6	6
SHAFTS CENTER DISTANCE (mm)	265-313	265-313	265-313	265-313	265-313	265-313	232-279

¹ Standard Motor, Standard Drive Only

HIGH-STATIC DRIVE DATA, 60 Hz — SI

UNIT	BAC 075	BAC BHC 090	BAC BHC 120	BAC 150	BAC BHC 180	BAC 240/245
MOTOR DRIVE						
Motor Pulley Pitch Diameter (mm)	86.4-111.8	86.4-111.8	86.4-111.8	94.0-119.4	109.2-134.6	109.2-134.6
Pulley Factory Setting Full Turns Open	2.5	2.5	2.5	3.0	3.0	3.0
FAN DRIVE						
Pulley Pitch Dia (mm)	178	152	152	188	201	188
Pulley Bore (mm)	25.4	25.4	25.4	36.5	36.5	36.5
Belt No. — Section	1—A	1—A	1—A	1—B	1—B	2—B
Belt Pitch (mm)	1049	947	947	1011	1011	935
FAN SPEEDS (r/s)						
Factory Setting	16.0	18.7	18.7	16.3	17.7	18.6
Range	14.0-18.1	16.3-20.0†	16.3-20.0†	14.4-18.3	15.8-19.5	16.9-20.0†
Max Allowable Speed (r/s)	20.0	20.0	20.0	20.0	20.0	20.0
Change per 1/2 Turn of Moveable Motor Pulley Flange	0.410	0.478	0.478	0.323	0.307	0.323
MAX FULL TURNS FROM CLOSED POSITION	5	5	5	6	6	6
SHAFTS CENTER DISTANCE (mm)	265-313	265-313	265-313	265-313**	232-279	207-255

†It is possible to adjust drive so that fan speed exceeds maximum allowable. DO NOT exceed 20 r/s.

**575-v unit has a center distance of 233-279.

ACCESSORIES

ELECTRIC HEATER ACCESSORIES			
Heater Part Number	kW	V-PH-HZ	Used on Unit Size (Tons)
AAHC05AHA	5	208-3-60	6 to 10
		240-3-60	
AAHC05ALA	5	480-3-60	6 to 10
AAHC05ASA	5	575-3-60	6 to 10
AAHC10AHA	10	208-3-60	6 to 10
		240-3-60	
AAHC10ALA	10	480-3-60	6 to 10
AAHC10ASA	10	575-3-60	6 to 10
AAHC15AHA	15	208-3-60	6 to 10
		240-3-60	
AAHC15ALA	15	480-3-60	6 to 10
AAHC15ASA	15	575-3-60	6 to 10
AAHC25AHA	25	208-3-60	6 to 10
		240-3-60	
AAHC25ALA	25	480-3-60	6 to 10
AAHC25ASA	25	575-3-60	6 to 10
AAHC35CHA	35	208-3-60	7-1/2 to 10
		240-3-60	
AAHC35CLA	35	480-3-60	7-1/2 to 10
AAHC35CSA	35	575-3-60	7-1/2 to 10
AAHC10BHA	10	208-3-60	12-1/2 to 20
		240-3-60	
AAHC10BLA	10	480-3-60	12-1/2 to 20
AAHC10BSA	10	575-3-60	12-1/2 to 20
AAHC20BHA	20	208-3-60	12-1/2 to 20
		240-3-60	
AAHC20BLA	20	480-3-60	12-1/2 to 20
AAHC20BSA	20	575-3-60	12-1/2 to 20
AAHC30BHA	30	208-3-60	12-1/2 to 20
		240-3-60	
AAHC30BLA	30	480-3-60	12-1/2 to 20
AAHC30BSA	30	575-3-60	12-1/2 to 20
AAHC50DHA	50	208-3-60	15 & 20
		240-3-60	
AAHC50DLA	50	480-3-60	15 & 20
AAHC50DSA	50	575-3-60	15 & 20

ACCESSORIES		
Model Number	Description	Used on Unit Size (Tons)
AGRC01AA	RETURN AIR GRILLE	6 to 10
AGRC02BA	RETURN AIR GRILLE	12-1/2 to 20
ASPC01AA	STEAM COIL (1 ROW)	6 to 10 Ton
ASPC02BA	STEAM COIL (1 ROW)	12-1/2 to 20
ASBC01A	FLOOR MOUNT BASE (SUBBASE)	6 to 20
AHBC01A	OVERHEAD SUSPENSION BRACKETS	6 to 20
ACSC01A	CONDENSATE OVERFLOW SWITCH	6 to 20
APDC01AA	DISCHARGE PLENUM	6 to 10
APDC02BA	DISCHARGE PLENUM	12-1/2 to 20
AEMC01AA	ECONOMIZER	6 to 10
AEMC02BA	ECONOMIZER	12-1/2 to 20
AHWC01AA	HOT WATER COIL (2 ROW)	6 to 10
AHWC02BA	HOT WATER COIL (2 ROW)	12-1/2 to 20

GUIDE SPECIFICATIONS

Commercial Packaged Air-Handling Unit

HVAC Guide Specifications

Size Range: **2,400 to 8,000 Cfm (1150 to 3766 L/s), Nominal Airflow 6 to 20 Tons (21 to 70 kW), Nominal Cooling**

Model Numbers: **BAC (Direct-Expansion Coil) BHC (Direct-Expansion Heat Pump Coil)**

PART 1 - GENERAL

1.01 SYSTEM DESCRIPTION

- A. Indoor, packaged air-handling unit for use in commercial split systems. Unit shall have a multiposition design and shall be capable of horizontal or vertical installation on a floor or in a ceiling, with or without ductwork. (Only vertical units are to be applied without ductwork.)
- B. Unit with direct-expansion coil shall be used in a refrigerant circuit with a matching air-cooled condensing unit.

1.02 QUALITY ASSURANCE

- A. Coils shall be designed and tested in accordance with ASHRAE 15 Safety Code for Mechanical Refrigeration (U.S.A.), latest edition.
- B. Unit shall be constructed in accordance with ETL (U.S.A.) and ETL, Canada, standards and shall carry the ETL and ETL, Canada, labels.
- C. Unit insulation and adhesive shall comply with NFPA-90A (U.S.A.) requirements for flame spread and smoke generation. Insulation shall contain an EPA-registered immobilized antimicrobial agent to effectively resist the growth of bacteria and fungi as proven by tests in accordance with ASTM standards G21 and 22 (U.S.A.).
- D. Unit shall be manufactured in a facility registered to the ISO 9002 manufacturing quality standard.
- E. Direct-expansion coils shall be burst and leak tested at 435 psi (2999 kPa).

1.03 DELIVERY AND STORAGE

Units shall be stored and handled per manufacturer's recommendations.

Part 2 - Products

2.01 EQUIPMENT

Indoor mounted, draw-thru, packaged air-handling unit that can be used in a suspended horizontal configuration or a vertical configuration. Unit shall consist of forward-curved belt-driven centrifugal fan(s), motor and drive assembly, prewired fan motor contactor, factory-installed refrigerant metering

devices (direct-expansion coil units), cooling coil, 2-in. (51-mm) disposable air filters, and condensate drain pans for vertical or horizontal configurations.

A. Base Unit:

1. Cabinet shall be constructed of mill-galvanized steel.
2. Cabinet panels shall be fully insulated with 1/2-in. (12.7-mm) fire-retardant material. Insulation shall contain an EPA registered immobilized antimicrobial agent to effectively resist the growth of bacteria and fungi as proven by tests in accordance with ASTM standards G21 and 22 (U.S.A.).
3. Unit shall contain PVC condensate drain pans for both vertical and horizontal applications. Drain pans shall have connections on right and left sides of unit to facilitate field connection. Drain pans shall have the ability to be sloped toward the right or left side of the unit to prevent standing water from accumulating in pans.
4. Unit shall have factory-supplied 2-in. (51 mm) throwaway-type filters installed upstream from the cooling coil. Filter access shall be from either the right or left side of the unit.

B. Coils:

Coils shall consist of 3 rows (BAC, BHC090), or 4 rows (BHC120/150) of copper tubes with sine-wave aluminum fins bonded to the tubes by mechanical expansion. Suction and liquid line connections or supply and discharge connections shall be made on the same side of the coil.

1. Direct-expansion coils shall feature factory-installed thermostatic expansion valves (TXVs) for refrigerant control. The TXVs shall be capable of external adjustment. Direct-expansion heat pump coils shall have a factory-installed bypass line and check valve assembly around the TXVs to allow liquid flow from the coil to the outdoor unit during the heating mode. Coil tubing shall be internally rifled to maximize heat transfer.

C. Operating Characteristics:

Unit shall be capable of providing _____ cfm (L/s) airflow at an external static pressure of _____ in. wg (kPag).

D. Motor:

Fan motor of the size and electrical characteristics specified on the equipment schedule shall be factory supplied and installed.

Motors rated at 1.3 through 3.7 hp (0.97 through 2.76 kW) shall have internal thermal overload protection. Motors rated at 5 and 7 1/2 hp (3.73 and 5.60 kW) shall be protected by a circuit breaker.

E. Factory-Installed Options:

1. Alternate Motor and Drive:

An alternate motor and/or medium- or high-static drive shall be available to meet the airflow and external static pressure requirements specified on the equipment schedule.

F. Field-Installed Accessories:

1. Hot Water Coil:

Coil shall be 2-row, U-bend coil with copper tubes and aluminum plate fins bonded to the tubes by mechanical expansion. Coil shall be mounted in a galvanized steel housing that shall be fastened to the unit's fan deck for blow-thru heating operation. Coil shall have maximum working pressure of 150 psig (1034 kPag).

2. Steam Distributing Coil:

Coil shall consist of one row of copper tubes with aluminum plate fins, and shall have inner steam distributing tubes. Coil shall be mounted in a galvanized steel housing and shall be fastened to the unit's fan deck for blow-thru heating operation. Coil shall have maximum working pressure of 175 psig at 400 F (1207 kPag at 204.4 C).

3. Electric Heaters:

Heaters for nominal 240, 480, or 575-volt, 3-phase, 60 Hz; power supply shall be factory-supplied for field installation as shown on the equipment drawings. Electric heat assembly shall be ETL (U.S.A.) and ETL, Canada, agency approved, and shall have single-point power wiring. Heater assembly shall include contactors with 24-v coils, power wiring, 24-v control wiring terminal blocks, and a hinged access panel. Electric heaters shall not be used with air discharge plenum.

4. Air Discharge Plenum:

Plenum shall be factory supplied to provide free-blow air distribution for vertical floor mounted units. A grille with moveable vanes for horizontal or vertical airflow adjustment shall be included. Plenum shall be field-assembled and field-installed on the unit's fan deck for blow-thru air distribution. Plenum shall not be used with electric heaters.

5. Return Air Grille:

Grille shall be factory supplied for field installation on the unit's return air opening.

6. Unit Subbase:

Subbase assembly shall be factory supplied for field installation. Subbase shall elevate floor-mounted vertical units to provide access for correct condensate drain connection.

7. Economizer:

Economizer for ventilation or "free" cooling shall be factory provided for field installation on either return air opening of air handler. For free cooling applications, economizer shall be compatible with separate thermostat; economizer dampers shall open when outdoor air enthalpy is suitable for free cooling. Economizer shall be compatible with separate CO₂ sensor accessory; economizer dampers shall open when indoor CO₂ level rises above predetermined set point. Economizer shall include enthalpy control and damper actuator.

8. Overhead Suspension Package:

Package shall include necessary brackets to support units in a horizontal ceiling installation.

9. Condensate Drain Trap:

Trap shall have transparent, serviceable design for easy cleaning. Kit shall include overflow shutoff switch and wiring harness for connection to an alarm if desired.