

INSTALLATION INSTRUCTIONS

HORIZONTAL/DOWNFLOW CONVERSION GASKET KIT

FOR FAN COILS

EBAC01GSK

NOTE: Read the entire instruction manual before starting the installation.

SAFETY CONSIDERATIONS

Installing, starting up, and servicing air-conditioning equipment can be hazardous due to system pressures, electrical components, and equipment location (roofs, elevated structures, etc.).

Only trained, qualified installers and service mechanics should install, start-up, and service this equipment.

Untrained personnel can perform basic maintenance functions such as cleaning coils. All other operations should be performed by trained service personnel.

When working on the equipment, observe precautions in the literature and on tags, stickers, and labels attached to the equipment.

Follow all safety codes. Wear safety glasses and work gloves. Keep quenching cloth and fire extinguisher nearby when brazing. Use care in handling, rigging, and setting bulky equipment.

Read these instructions thoroughly and follow all warnings or cautions included in literature and attached to the unit. Consult local building codes and National Electrical Code (NEC) for special requirements. In Canada, refer to current editions of the Canadian Electrical Code, CSA 22.1.

Recognize safety information. This is the safety-alert symbol . When you see this symbol on the unit and in instructions or manuals, be alert to the potential for personal injury. Understand these signal words: DANGER, WARNING, and CAUTION. These words are used with the safety-alert symbol. DANGER identifies the most serious hazards which **will** result in severe personal injury or death. WARNING signifies hazards which **could** result in personal injury or death. CAUTION is used to identify unsafe practices which **may** result in minor personal injury or product and property damage. NOTE is used to highlight suggestions which **will** result in enhanced installation, reliability, or operation.



WARNING

FIRE, EXPLOSION, ELECTRICAL SHOCK HAZARD

Failure to follow this warning could result in personal injury, death and/or property damage.

The ability to properly perform maintenance on this equipment requires certain knowledge, mechanical skills, tools, and equipment. If you do not possess these, do not attempt to perform any maintenance on this equipment.



WARNING

ELECTRICAL SHOCK HAZARD

Failure to follow this warning could result in personal injury or death.

Before installing, modifying, or servicing system, main electrical disconnect switch must be in the OFF position and install a lockout tag. There may be more than one electrical supply to the fan coil. Check accessories and cooling unit for additional electrical supplies that must be shut off during fan coil servicing. Lockout and tag switch with a suitable warning label. Verify proper operation after servicing.



CAUTION

CUT HAZARD

Failure to follow this caution may result in personal injury.

Sheet metal parts may have sharp edges or burrs. Use care and wear appropriate clothing, safety glasses and gloves when handling parts and servicing fan coil.

INTRODUCTION

This instruction covers the installation of this gasket kit on models FVM, FCM, FEM, FSM, FSU, EBP, EBX, EBW, EBV, WAH, WAP, WAX fan coils. This kit is required when converting the low leak/low sweat fan coils and helps retain their performance after the conversion.

DESCRIPTION AND USAGE

This gasket kit is used in conjunction with downflow conversion kits, downflow base kit and in the conversion of slope coil units to horizontal right airflow.

INSTALLATION

1. Cut gasket 1 and gasket 2 to length as follows:
 - a. For the 14.2" cabinet–325mm (12.75")
 - b. For the 17.5" cabinet–410mm (16.12")
 - c. For the 21" cabinet–499mm (19.62")
 - d. For the 24.5" cabinet–use as is
2. Apply gasket 1 referring to Fig. 1. Center in the first flange with slight overhang on both ends. Cover the flange completely.
3. Apply gasket 2 referring to Fig. 1. Center on the second flange with slight overhang on each end. Align the notch with the flange notch.

This gasket will have slight overhang of the flange edges.

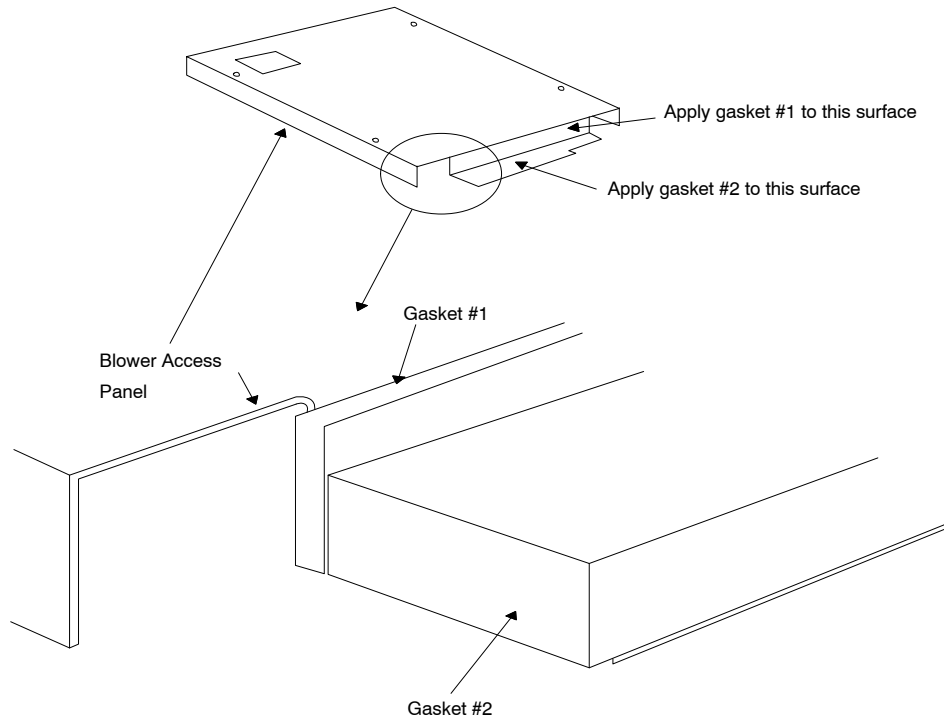

Fig 1 - Gasket Application on the Blower Access Panel