

BA-400/400S

1/4"-2"

**BRONZE BALL VALVE
TWO-PIECE, FULL-PORT
600 PSIG WOG / 150 PSIG SWP (1)
THREADED ENDS**

FED. SPEC. WW-V-35C, II, BZ, 3
MSS SP-110

MATERIALS LIST

ITEM	PART	MATERIALS	ASTM SPEC.
1	Body	Cast Bronze	B584
2	Tailpiece	Brass	B283
		Cast Bronze (1 1/4" & up)	B584
3	Ball	Brass w/ Hard Chrome Plating	B283
		316 Stainless Steel (2)	B276
4	Seat	RPTFE, 15% Glass Filled	
5	Stem	Brass	B16
		316 Stainless Steel (2)	B276
6	Thrust Washer	RPTFE, 25% Glass Filled	
7	Packing	PTFE	
8	Packing Nut	Brass	B16
9	Handle	Steel w/ Zinc Plating	Commercial
10	Hand Grip	Vinyl	
11	Handle Nut	Steel w/ Zinc Plating	Commercial

- (1) Milwaukee Valve Company recommends the use of stainless steel ball and stem for steam applications. Please consult factory for more information.
- (2) Ball and stem are stainless for 400S.
- (3) For steam service, specify stainless trim and multi-fill seats, maximum stem pressure 150.

PRESSURE - TEMPERATURE DATA

VALVES RATED FOR VACUUM SERVICE TO 29 INCHES Hg.

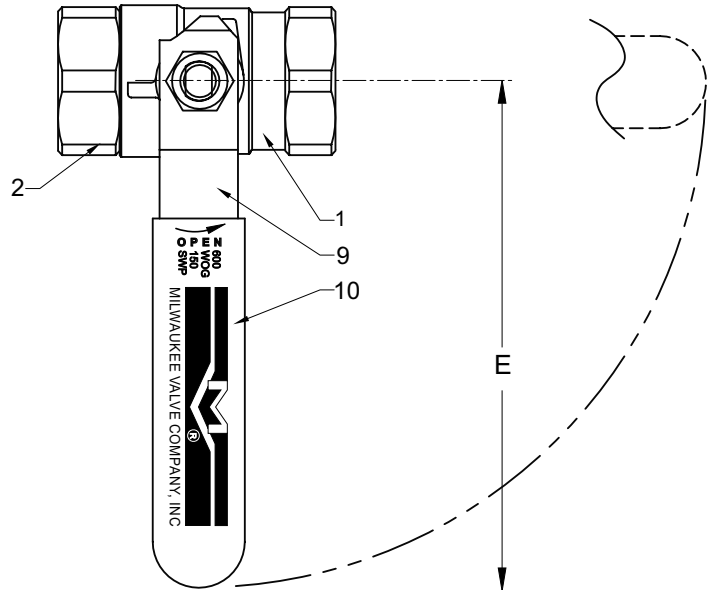
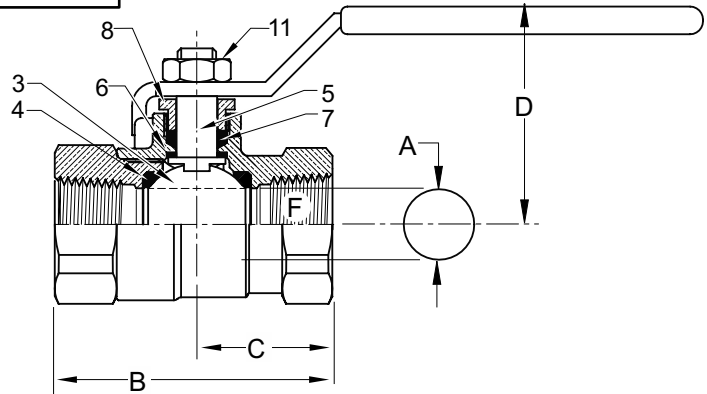
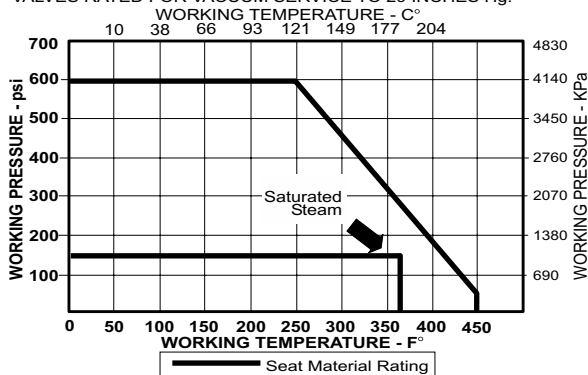

DIMENSIONS

	UNITS	1/4"	3/8"	1/2"	3/4"	1"	1-1/4"	1-1/2"	2"
		DN6	DN10	DN15	DN20	DM25	DM32	DN40	DN50
A(DIA)	INCHES	0.38	0.38	0.50	.76	1.06	1.31	1.56	2.00
	mm	9.7	9.7	12.7	19.3	26.9	33.3	39.6	51.0
B	INCHES	1.86	1.86	2.19	2.59	3.32	3.77	4.28	5.10
	mm	45.6	45.6	53.7	65.8	84.3	95.8	108.7	129.5
C	INCHES	1.00	1.00	1.10	1.30	1.59	1.81	2.06	2.37
	mm	24.5	24.5	27.0	33.0	40.4	46.0	52.3	60.2
D	INCHES	1.78	1.81	1.91	2.32	2.68	2.82	3.00	3.36
	mm	43.6	44.3	46.8	58.9	68.1	71.6	76.2	85.3
E	INCHES	3.82	3.82	3.82	4.55	6.33	6.33	6.33	7.19
	mm	93.6	93.6	93.6	115.6	160.8	160.8	160.8	182.6
F	THREAD SIZE	1/4" NPT	3/8" NPT	1/2" NPT	3/4" NPT	1" NPT	1-1/4" NPT	1-1/2" NPT	2" NPT
Cv		7	7	13	30	61	110	185	360

Note: DN (Diameter Nominal) = Metric equivalent size.

Rev. 11

The information presented on this sheet is correct at the time of publication. Milwaukee Valve reserves the right to change design, and/or material specifications without notice. For the most current information access www.milwaukeevalve.com

