

DIMENSIONS- ENGLISH UNITS FOR CLASS 150		DIMENSIONS- METRIC UNITS FOR CLASS PN 20	
NOMINAL VALVE SIZE	6	NOMINAL VALVE SIZE	150
A END TO END, WELDING ENDS, FIG 1945 1/2	18.0	A END TO END, WELDING ENDS, FIG 1945 1/2	457
E CENTER TO TOP OF STEM	10.4	E CENTER TO TOP OF STEM	264
F CENTER TO BOTTOM	6.5	F CENTER TO BOTTOM	164
J WIDTH OF FLAT	1.25	J WIDTH OF FLAT	32
K DIAMETER OF STEM	1.8	K DIAMETER OF STEM	46
L HEIGHT OF FLAT	1.16	L HEIGHT OF FLAT	29
M EXTREME WIDTH OF BODY	8.7	M EXTREME WIDTH OF BODY	221
WRENCH SIZE	DB-4	WRENCH SIZE	DB-4
WEIGHT, LBS., FIG. 1945 1/2	180	WEIGHT, KGS., FIG. 1945 1/2	81

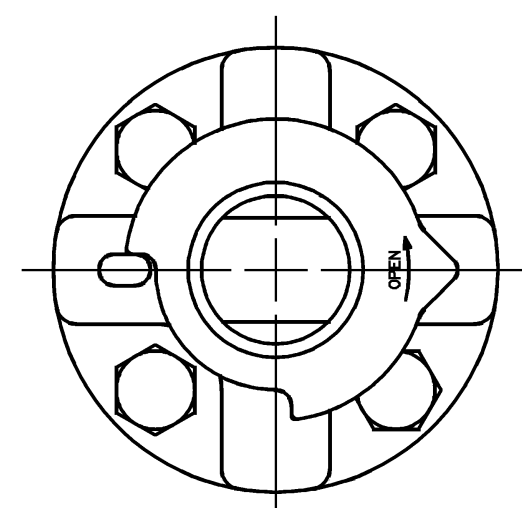

CATEGORY "A"
-20°F TO +450°F

LIST OF MATERIALS		
REF	NAME	MATERIAL
1	BODY	A216 GR WCC
2	PLUG	A48 CL 50
3	COVER	A516 GR 70
4	COVER CAPSCREW	A193 GR B7
5	THRUST BALL	A295 GR 52100
6	THRUST BALL SEAT	A322 GR 4140
7	RING GASKET	A366
8	DIAPHRAGM THIN	A167 T430
9	DIAPHRAGM	A109
10	THRUST BUTTON	MILD STEEL
11	ADJUSTING SCREW	CARBON STEEL
12	ADJ. SCREW COVER	A36
13	CAPSCREW	A449 SAE GR5
14	WEATHERSEAL	NEOPRENE
15	BALANCE BALL	A276 T440C
16	SPRING	A313 T302
17	CHECK VALVE	CARBON STEEL BODY & BALL, T302 PIN
18	SEALANT FITTING	A108 CARB STL ZINC PLATE
19	EQUALIZER	A668 GR 4140
20	PACKING	GRAPHITE/TEFLON
21	WASHER	ZINC FOIL
22	ADJ SCR COVER GSMT	GARLOCK CP-3900 OR EQUAL
23	CAPSCREW	A193 GR B7
24	PLUG STEM	A582 T416
25	WEATHERSEAL	BUNA-N
26	JUNK RING	A519 GR 1018
27	THRUST BEARING	FIBERGLASS/TEFLON, STEEL BACKED
28	GLAND	HI ELONGATION IRON
29	STOP COLLAR	MILD STEEL
30	NAMEPLATE	A167 T304
31	RETAINER RING	CARBON STEEL
32	BALL RET. WASHER	A167 T316

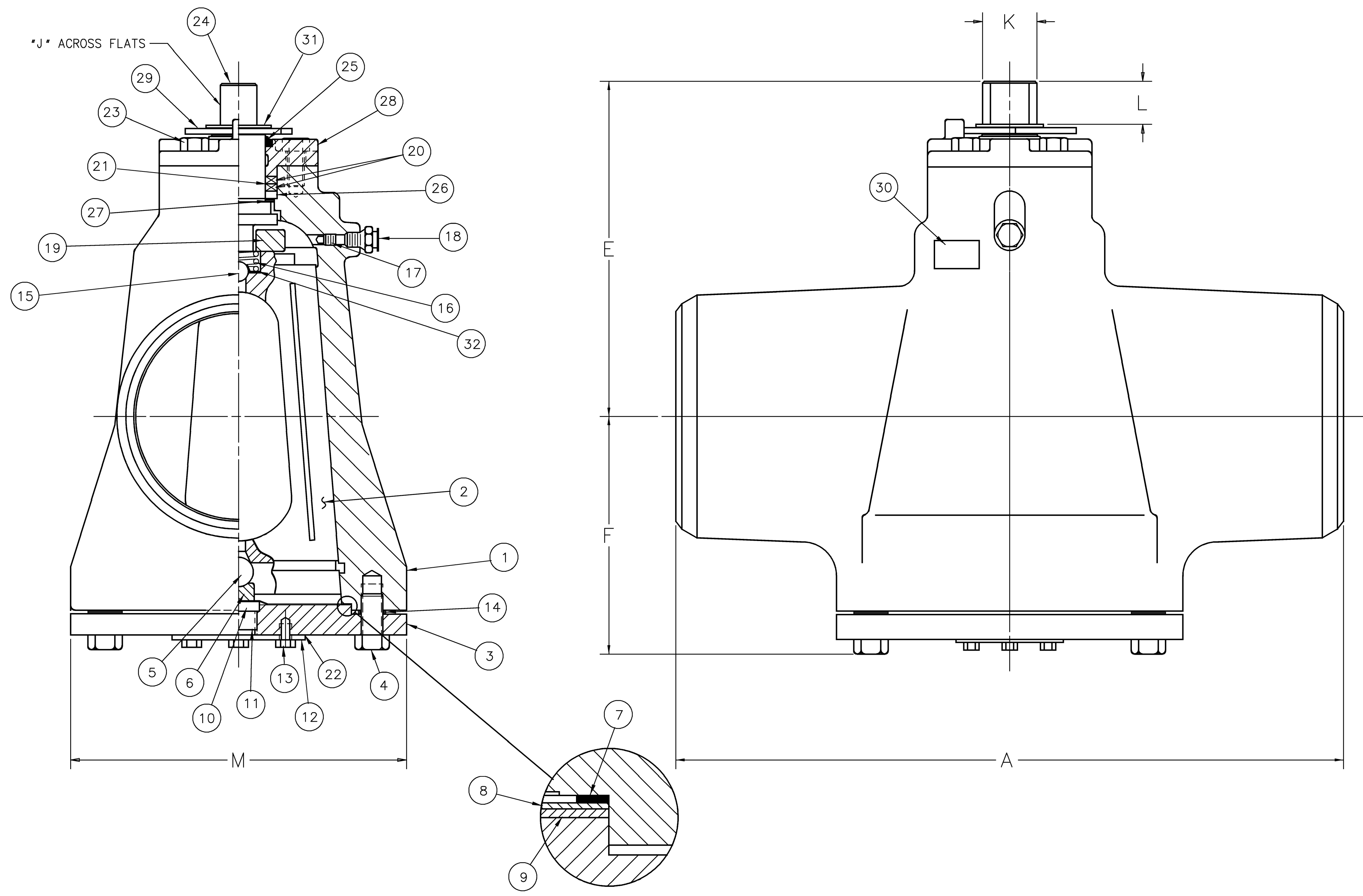

- NOTES:
1. DIMENSIONS SHOWN ARE NOMINAL, PROVIDED FOR GENERAL INFORMATION, AND AS SUCH ARE SHOWN WITHOUT TOLERANCE.
 2. DIMENSIONS SUBJECT TO CHANGE WITHOUT NOTICE.
 3. DIMENSIONS IN INCHES AND MILLIMETERS.
 4. VALVES CONFORM TO API 6D & ASME/ANSI B16.34.
 5. SEE DRAWING C-484753 FOR TOPWORKS AND OPERATOR MOUNTING DIMENSIONS.

FLOWERVE Nordstrom Valves

SULPHUR SPRINGS, TEXAS

DYNAMIC BALANCE PLUG VALVE

SUPERSEDES: REF. DWG.

DRWN	CHKD	APPD	SCALE: NONE	DATE: 9/25/07
DH	JDI	JDI	B-2767285	

BY / DATE	CNS NO.	REV