



# INSTALLATION INSTRUCTIONS

## For Juno T, TU and V Series Trac

Read all of these installation instructions before installing the Trac system. Save these instructions and refer to them when additions or changes in the Trac configuration are made. Use only fixtures and fittings intended for use with Juno T, TU or V series Trac.

### POLARITY

All Trac components are mechanically and visually polarized to assure proper connections.

### NOTE:

1. Trac face has a polarity line indicating "p" positive side.
2. Trac connectors have arrow which must point to polarity line.
3. Fixture adapter has arrows which must point to the polarity line.
4. Make sure power is OFF before wiring.

### One Circuit Installation Data

#### Electrical Feed at Outlet Box and Mechanical Installation

##### A. To Mount Trac:

1. Attach fixture strap to outlet box.
2. Insert feed connector into Trac and secure with set screw.
3. Attach Trac to ceiling with toggle bolts or screws (if T-bar ceiling uses T-bar clips, order separately). Maximum distance between clips is 4'.
4. If the Trac is pendant mounted, maximum pendant spacing is 4' (minimum two pendants per Trac section).
5. Lock feed connector to nipple with lock nut.

##### B. To Wire Trac:

1. Use No. 12 or 14 AWG solid wire, copper only.
2. Pull wire through outlet box, fixture strap and connector.
3. Fasten positive wire to screw terminal marked P.
4. Fasten white wire (neutral) to screw terminal marked N.
5. Replace connector cover, secure with screw.

##### C. See fixture instructions for fixture installation to Trac.

##### D. Rated 120V, 60HZ, 20A.

### Two Circuit Installation Data

#### Electrical Feed at Outlet Box and Mechanical Installation

##### A. To Mount Trac:

1. Attach fixture strap to outlet box.
2. Insert feed connector into Trac and secure with set screw.
3. Attach Trac to ceiling with toggle bolts or screws (if T-bar ceiling uses T-bar clips, order separately). Maximum distance between clips is 4'.
4. If the Trac is pendant mounted, maximum pendant spacing is 4' (minimum two pendants per Trac section).
5. Lock feed connector to nipple with lock nut.

##### B. To Wire Trac:

1. Use No. 12 or 14 AWG solid wire, copper only.
2. Pull wire through outlet box, fixture strap and connector.
3. Fasten one positive wire to screw terminal marked P1.
4. Fasten second positive wire to screw terminal marked P2.
5. Fasten white wire (neutral) to screw terminal marked N.
6. Replace connector cover, secure with screw.

##### C. See fixture instructions for fixture installation to Trac.

##### D. Rated 120V/240V, 60HZ, single-phase, 3-wire, grounded neutral.

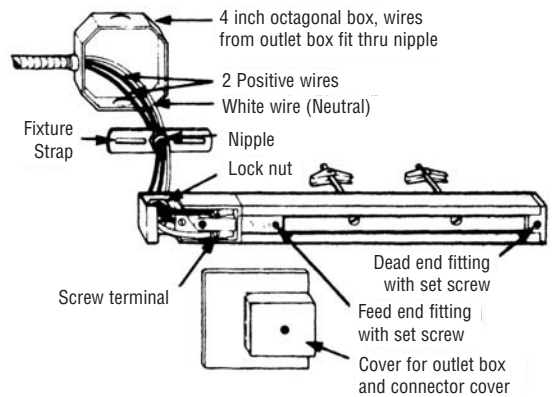
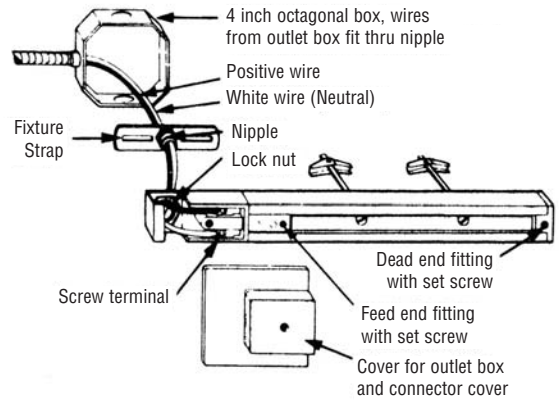
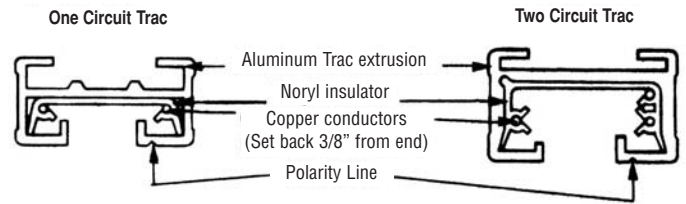

### Two Circuit Wiring Information

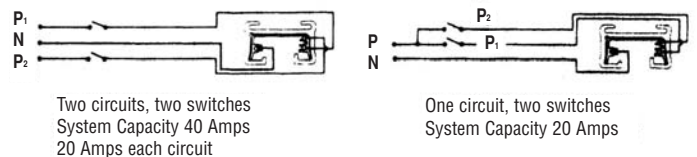

Product Services Phone (888) 387-2212

1300 South Wolf Road • Des Plaines, IL 60018 • Phone 800-323-5068 • www.junolightinggroup.com



JUNO LIGHTING GROUP  
by Schneider Electric



# INSTALLATION INSTRUCTIONS

## For Juno T, TU and V Series Trac

### IMPORTANT SAFETY INSTRUCTIONS

1. Read all instructions.
2. Do not install this Trac in damp or wet locations.
3. Do not install any part of Trac system less than 5' above floor.
4. Do not install any fixture assembly closer than 6 inches from any curtain or similar material.
5. Disconnect electrical power before adding to or changing the configuration of the Trac.
6. Do not attempt to energize anything other than lighting fixtures on the Trac. To reduce the risk of fire or electrical shock, do not attempt to connect power tools, extension cords, convenience receptacle adapters, appliances or the like to the Trac.
7. Trac not intended to be connected with power cord or to more than one branch circuit. (Exception: Two-circuit Trac may be connected to two branch circuits.) If improperly wired, the Trac system may appear to operate acceptably, but a dangerous overload of the neutral may occur and result in a risk of fire. Check with a qualified electrician before wiring Trac.

### FIELD CUTTING INSTRUCTIONS

1. When cutting Trac, the aluminum extrusion and the Trac insulator must be the same length. A fine tooth hacksaw is recommended for cutting. Remove the dead end, push the insulator and buss bars until they are flush with one end of the Trac, then cut at the **opposite** end to the length required. Carefully de-burr the cut end and make sure that no chips or filings remain in the Trac.
2. Push the buss bars partially out of the Trac and trim 11/16" to 13/16" from the buss bars for proper insertion of the connectors. Replace dead end.
3. Each end of the Noryl insulator that will have a connector inserted into it must have a notch cut into the center of the insulator. Using the end of the insulator that has been cut off as a pattern, cut a notch 5/8" long by 1/8" wide in the end of the insulator using a utility knife or scissors. (Not required on TU series Trac)
4. Push the insulator and the buss bars fully into the Trac and insert the appropriate connector.

### DRILLING INSTRUCTIONS

1. When a new mounting hole is required in a piece of Trac, it must be placed on the Trac centerline. If the new hole is in the end of the Trac section, it must be no closer that 2" nor farther that 6" from the end of the Trac.
2. Locate and drill a 1/4" diameter hole through the Trac and insulator. Carefully de-burr the hole and make sure that there are no chips or filings that remain in the Trac.
3. A minimum of two mounting holes is required per Trac section. Maximum distance between mounting holes is 4'.

### 2 Circuit Trac Installation of Spotlights

#### Circuit #1 (lower circuit)

- A. Insert spotlight contacts into Trac channel.
- B. Rotate adapter 90° so that polarity arrows point to the polarity line.

#### Circuit #2 (upper circuit)

- A. Raise contact marked "P" (switch side) by inserting a thin screwdriver blade under contact. Pull up into position (Fig. 1).
- B. Insert contact support (supplied with 2 circuit Trac section) by tipping and positioning under "P" contact (Fig. 2).
- C. Insert spotlight into Trac as per circuit #1 A & B above.

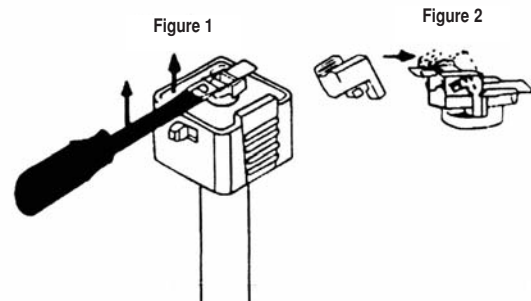

• **IMPORTANT** •  
Retain for use with Trac Lights

Product Services Phone (888) 387-2212

1300 South Wolf Road • Des Plaines, IL 60018 • Phone 800-323-5068 • www.junolightinggroup.com



JUNO LIGHTING GROUP  
by Schneider Electric