

Specifications

3/4" MALE X FEMALE HOSE THREAD WATER HAMMER ARRESTOR



Product Features

- Helps to eliminate shock waves generated in piping systems by sudden on/off changes in flow
- Brass piston
- Designed for laundry applications
- AA arrestors are suitable for 1-3 fixture units
- May be installed at any angle
- To function more effectively, please install within 6 feet of the fixture the arrestor is servicing.
- Temperature range: 33°F to 180°F
- Max. working pressure: 350psi
- cUPC/IAPMO listed
- Connection Size: 3/4" Male Hose Thread X 3/4" Female Hose Thread



PFMM500L

Product Specifications

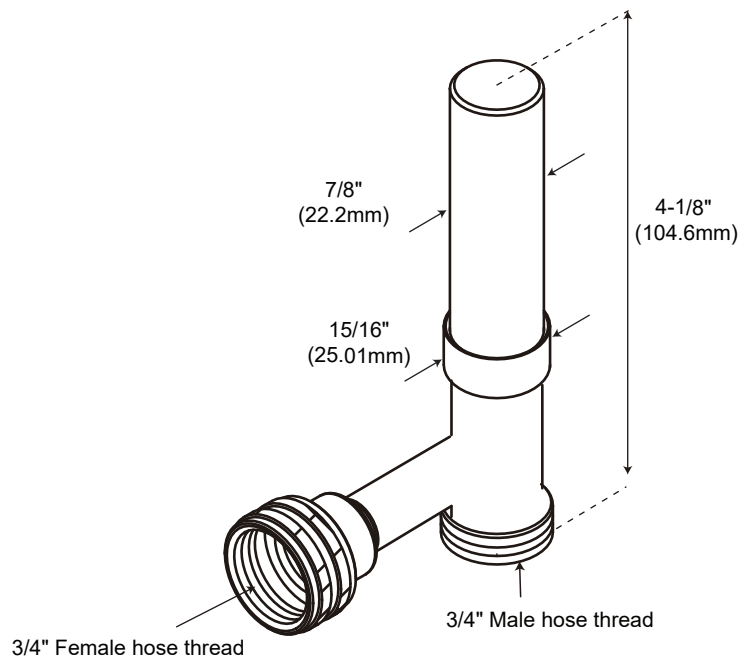

* All measurements are nominal. Please verify before actual installation.

Warranty and Codes

This PROFLO product carries a 1-year limited warranty.

©2023 Ferguson Enterprises, LLC. FG 03/2023-B



FERGUSON.COM/PROFLO