

TEST TEES

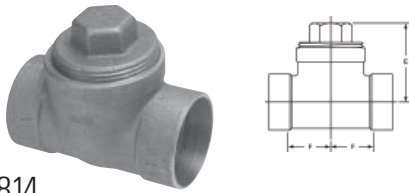

814
DWV Test Tee
C x C x Cleanout w/Plug – Cast

NOM. SIZE	APPROX. NET WT./LBS.	DIM. E INCHES	DIM. F INCHES
1 1/2	1.00	2 ¹ / ₁₆	1 ¹ / ₈
2	1.35	2 ¹¹ / ₃₂	1 ³ / ₈
3	3.78	3 ⁷ / ₁₆	1 ¹⁵ / ₁₆

T-Y's

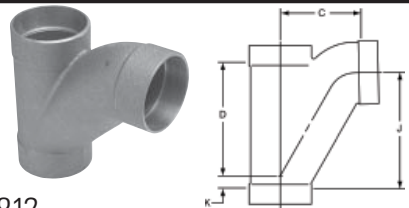

812
DWV Long Turn T-Y
C x C x C – Cast

NOM. SIZE	APPROX. NET WT. LBS.	DIMENSIONS INCHES			
		C	D	J	K
§ 1 1/4	0.93	2 ²⁷ / ₃₂	1 ²⁷ / ₃₂	2 ³ / ₄	1 ³ / ₃₂
1 1/2	0.87	3 ⁵ / ₁₆	2 ¹ / ₈	3 ⁵ / ₃₂	7 ¹ / ₁₆
2	1.84	4 ¹ / ₄	2 ³ / ₄	4 ¹ / ₁₆	1 ¹ / ₂
2 x 2 x 1 1/2	1.07	3 ⁵ / ₈	2 ³ / ₈	3 ⁷ / ₃₂	7 ¹ / ₃₂
3	3.49	6 ⁷ / ₁₆	4 ¹ / ₃₂	6 ¹ / ₃₂	3 ³ / ₄
3 x 3 x 2	2.78	4 ⁷ / ₈	3 ⁵ / ₁₆	4 ⁵ / ₃₂	3 ³ / ₃₂

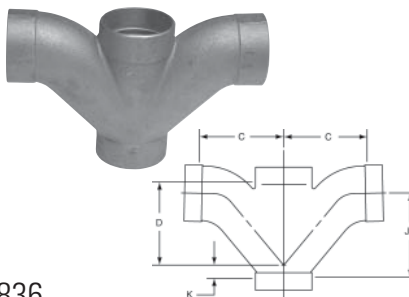

836
DWV Double Long Turn T-Y
C x C x C x C – Cast

NOM. SIZE	APPROX. NET WT. LBS.	DIMENSIONS INCHES			
		C	D	J	K
1 1/2	1.25	3 ⁵ / ₁₆	2 ¹ / ₈	3 ⁵ / ₃₂	7 ¹ / ₃₂
2	0.87	3 ⁵ / ₁₆	2 ¹ / ₈	3 ⁵ / ₃₂	7 ¹ / ₁₆
2 x 2 x 1 1/2 x 1 1/2	1.96	3 ⁵ / ₈	2 ³ / ₈	3 ⁷ / ₃₂	7 ¹ / ₃₂
2 x 2 x 1 1/4 x 1 1/4	2.67	3 ¹¹ / ₁₆	2 ³ / ₈	3 ⁷ / ₃₂	7 ¹ / ₃₂

Y's continued

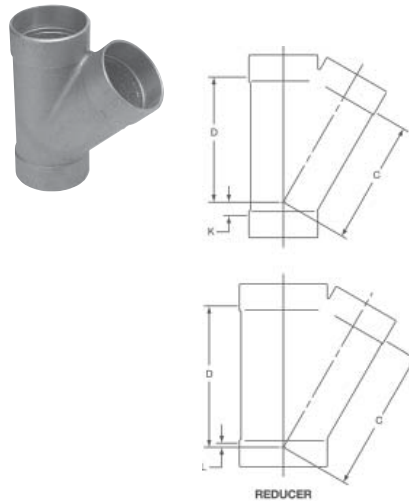

810
DWV 45° Y
C x C x C – Cast

NOM. SIZE	APPROX. NET WT. LBS.	DIMENSIONS INCHES			
		C	D	K	L
1 1/4	0.60	2	2	3 ³ / ₈	–
1 1/2	0.94	2 ⁵ / ₁₆	2 ⁵ / ₁₆	1 ¹ / ₂	–
2	1.26	2 ⁷ / ₈	2 ⁷ / ₈	1 ⁷ / ₃₂	–
2 x 2 x 1 1/2	1.15	2 ¹¹ / ₁₆	2 ⁹ / ₁₆	3 ¹ / ₁₆	–
2 x 2 x 1 1/4	1.01	2 ⁹ / ₁₆	2 ¹¹ / ₃₂	1 ¹ / ₁₆	–
2 x 1 1/2 x 2	1.16	2 ¹⁷ / ₃₂	2 ⁵ / ₈	1 ⁷ / ₃₂	–
2 x 1 1/2 x 1 1/2	0.84	2 ⁵ / ₃₂	2 ⁵ / ₃₂	5 ¹ / ₁₆	–
3	3.19	4 ¹ / ₆₄	4 ¹ / ₆₄	4 ⁵ / ₆₄	–
3 x 3 x 2	2.02	3 ¹⁷ / ₃₂	3 ⁵ / ₁₆	1 ¹ / ₈	–
3 x 3 x 1 1/2	1.69	3 ¹ / ₄	2 ¹⁵ / ₁₆	–	3 ¹ / ₁₆
4	5.55	5 ¹⁵ / ₃₂	5 ¹⁵ / ₃₂	1 ¹ / ₁₆	–
4 x 4 x 3	3.96	4 ¹ / ₁₆	4 ¹ / ₂	5 ¹ / ₁₆	–
4 x 4 x 2	2.90	4 ⁷ / ₃₂	3 ¹³ / ₁₆	–	3 ³ / ₈

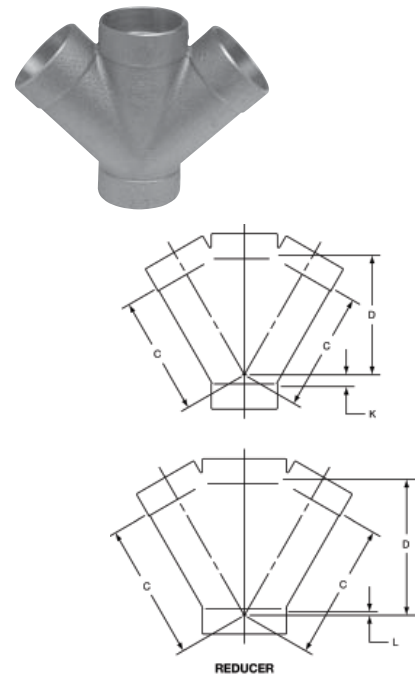

834
DWV 45° Double Y
C x C x C x C – Cast

NOM. SIZE	APPROX. NET WT. LBS.	DIMENSIONS INCHES			
		C	D	K	L
2	1.90	2 ⁷ / ₈	2 ⁷ / ₈	1 ⁷ / ₃₂	–
2 x 2 x 1 1/2 x 1 1/2	1.26	2 ¹¹ / ₁₆	2 ⁹ / ₁₆	3 ¹ / ₁₆	–
3	4.20	4 ¹³ / ₃₂	4 ¹³ / ₃₂	2 ⁵ / ₃₂	–
3 x 3 x 1 1/2 x 1 1/2	2.09	3 ¹ / ₄	2 ¹⁵ / ₁₆	–	5 ¹ / ₁₆

Consult price sheet for Made to Order items and for minimum order quantities.