

Figure 945-T, 945H-T Single Body Combination Air Valve for Clean Water

Description

GA Industries Figures 945-T Combination Air Valves are “triple function” valves. They vent air from pipelines and systems as they are being filled with water and then close tight once the system is full and pressurized. They also release air that accumulates in the valve while the system is operational. And, they automatically open to admit air to limit vacuum formation when the pipeline or system is drained and/or a negative pressure occurs in the valve.

The Figure 945-T Combination Air Valves are typically installed at high points in the system where air naturally rises during filling and in operation and vacuum first forms during draining.

Product Features

- Compact and light weight
- Full port orifice for maximum air outflow and inflow
- Utilizes “kinetic” operating principle, designed not to blow shut
- Rugged iron body and cover
- Corrosion resistant Type 316 stainless steel float
- Tight sealing and easily replaceable rubber seats

Standard Materials

- Body & Cover Cast Iron, ASTM A126 Class B
- Floats Stainless Steel, Type 316
- Internal Linkage Stainless Steel, Type 316
- Replaceable Seat Buna-N Rubber
- External Fasteners Type 316 Stainless Steel

Coating

- Standard: Uncoated internal, external coated with enamel primer, minimum 2 mil DFT
- Optional See Option P2



Approvals & Certifications

- Complies with AWWA Standard C512

Options/Accessories

- Option IV Inlet Isolating Valve – lever operated bronze ball valve (not available on 4”)
- Option OC Outlet Cowl – Deflects air outflow, minimizes debris from entering valve during inflow

Ordering Data

- Figure Number (945-T)
- Size
- Options/Accessories

Non-Shock Working Water Pressure at up to 150F (66C)						
Inlet Size	½", ¾", 1"	2"	3", 4"	½", ¾", 1"	2"	3", 4"
Figure Number	945-T			945H-T		
Inlet Connection	NPT			NPT		
Outlet Size	Same as Inlet			Same as Inlet		
Outlet Connection	NPT			NPT		
Air Release Orifice Diameter	0.094"	0.125"	0.188"	0.063"	0.094"	0.125"
Working Pressure	10 – 150 PSI			10 – 300 PSI		
Pressure Rating	300 PSI			300 PSI		
Hydro Test	450 PSI			450 PSI		

Figure 945-T, 945H-T Single Body Combination Air Valve for Clean Water

Data Sheet 945.01B

Air Vacuum Orifice

Pressure at Valve Inlet During Filling	Air Outflow Rate, Standard Cubic Feet/Min (SCFM)					
	1/2"	3/4"	1"	2"	3"	4"
1 PSI	19.6	44.2	78.5	314	707	1260
2 PSI	27.8	62.5	111	444	1000	1780
3 PSI	34.0	76.5	136	544	1220	2180
4 PSI	39.3	88.4	157	628	1410	2510
5 PSI	43.9	98.8	176	703	1580	2810
7 PSI	52.0	117	208	831	1870	3320
10 PSI	62.1	140	248	994	2240	3970
15 PSI	75.2	169	304	1217	2740	4870

Value is rate at which air is vented from pipeline/system during filling at valve inlet pressures shown. Inlet pressure during filling should not exceed 5 PSI.

Air Vacuum Orifice

Pressure at Valve Inlet During Draining	Air Inflow Rate, Standard Cubic Feet/Min (SCFM)					
	1/2"	3/4"	1"	2"	3"	4"
-1 PSIG	20.0	45.2	80	320	721	1280
-2 PSIG	28.3	63.9	113	453	1020	1810
-3 PSIG	34.7	78.3	138	555	1250	2220
-4 PSIG	40.1	90.4	160	641	1440	2560
-5 PSIG	44.9	101	179	716	1610	2870

Value is rate at which air is drawn into the valve at negative pipeline/system pressure shown. Multiply SCFM air inflow rate x 7.48 to convert to equivalent pipeline/system liquid draining rate in USGPM.

Air Release Orifice

Pressure At Valve Inlet	Air Release Orifice Venting Rate, Standard Cubic Feet/Min (SCFM)					
	Figure 945E-T			Figure 945EH-T		
	1/2", 3/4", 1"	2"	3", 4"	1/2", 3/4", 1"	2"	3", 4"
10 PSI	2.2	3.9	8.7	1.0	2.2	3.9
15 PSI	2.6	4.7	10.6	1.2	2.6	4.7
25 PSI	3.5	6.3	14.1	1.6	3.5	6.3
50 PSI	5.8	10.3	23.1	2.6	5.8	10.3
75 PSI	8.0	14.2	32.0	3.6	8.0	14.2
100 PSI	10.2	18.2	40.9	4.5	10.2	18.2
150 PSI	14.7	26.1	58.7	6.5	14.7	26.1
200 PSI				8.5	19.1	34.0
250 PSI				10.5	23.6	41.9
300 PSI				12.5	28.0	49.8

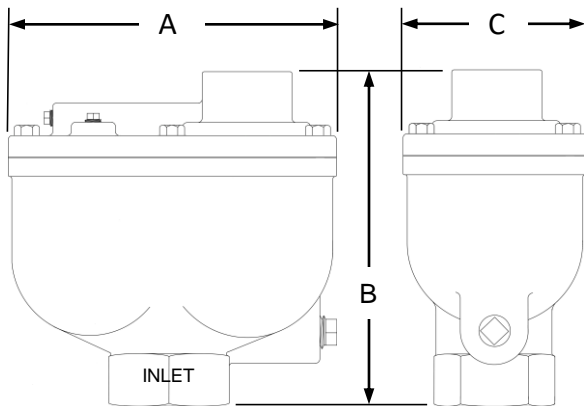

Installation Dimensions

SIZE	1/2", 3/4", 1"	2"	3"	4"
A	6 1/4"	9"	12 3/4"	15 1/4"
B (NPT Inlet)	7 1/4"	9 3/4"	12 1/4"	13 1/4"
C	3 3/8"	4 3/4"	6 3/8"	8 1/4"
E	2 5/8"	2 1/2"	3"	3 3/4"
F	4"	5"	8"	9"
G	7"	8"	13"	15"
Valve Weight	16 lbs.	30 lbs.	65 lbs.	120 lbs.
Add for Inlet Isolating Ball Valve	2 lbs.	8 lbs.	20 lbs.	30 lbs.
Add for Outlet Cowl	1 lb.	1 lb.	2 lbs.	4 lbs.

All dimensions and weights are approximate. If critical request certified drawings

INLET ISOLATING VALVE and/or OUTLET COWL

