

PARTS LIST		
ITEM	DESCRIPTION	MATERIAL
1.	BODY	CAST IRON, ASTM A126-B
2.	COVER	CAST IRON, ASTM A126-B
3.	SEAT (Air Vacuum)	BUNA-N RUBBER
4.	SUPPORT RING	316 STAINLESS STEEL
5.	FLOAT BALL (Air Vacuum)	316 STAINLESS STEEL
6.	SESAT SCREWS	18-8 STAINLESS STEEL
7.	COVER GASKET	ARMSTRONG CS-301
8.	COVER BOLTS	ZINC PLATED STEEL (Standard) 316 STAINLESS STEEL (Optional)
9.	ORIFICE	316 STAINLESS STEEL
10.	ORIFICE BUTTON	BUNA-N RUBBER
11.	LEVERAGE BRACKET	316 STAINLESS STEEL
12.	FLOAT ARM	316 STAINLESS STEEL
13.	FLOAT BALL (Air Release)	316 STAINLESS STEEL
14.	SPRING PIN	302 STAINLESS STEEL
15.	PIPE PLUG	STEEL
16.	SPRING PIN	302 STAINLESS STEEL
17.	LOCK WASHER	18-8 STAINLESS STEEL
18.	FLOAT SCREW	18-8 STAINLESS STEEL
19.	PIPE PLUG	STEEL
20.	REDUCING BUSHING (Note 1)	STEEL
21.	CUSHION	BUNA-N RUBBER
22.	BALL GUIDE	UHMWPE
23.	GUIDE BEARING	SELF-LUBRICATING POLYMER

Note 1. Item 20 used on 1/2" and 3/4" size only

FIGURE 945 COMBINATION AIR VALVES  
ARE MANUFACTURED AND TESTED IN  
ACCORDANCE WITH AWWA C512

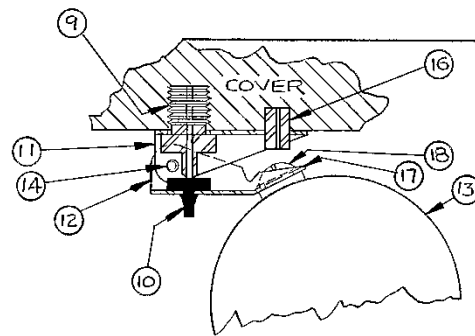

Section Through Air Release Linkage

FIGURE NUMBER	SIZE (INLET & OUTLET)	AIR RELEASE ORIFICE	MAX WORKING PRESSURE	WEIGHT
945	1/2", 3/4" or 1" NPT	3/32" (2,4mm)	150 PSI (1034KPa)	15 lb (6,8 Kg)
945-H	1/2", 3/4" or 1" NPT	1/16" (1,6mm)	300 PSI (2068KPa)	

<b>GA INDUSTRIES, a VAG Brand</b>		
DATE: 8-31-08	DRAWN BY: WJN	
<b>COMPACT KINETIC COMBINATION AIR VALVE</b>		
<b>FIGURE 945</b>	DRAWING NO. ECAV-7136-W	REV <b>A</b>