

Fig. 138R (Rod Threaded)

Extension Split Pipe Clamp

Size Range: 3/8" through 3"

Material: Malleable iron

Finish: Plain or Zinc Plated

Service: Recommended for non-insulated stationary pipe lines.

Maximum Temperature: 450° F

Approvals: Complies with Federal Specification A-A-1192A (Type 12)

WW-H-171-E (Type 25), ANSI/MSS SP-69 and MSS SP-58 (Type 12).

Features:

- Rapid installation assured by hinged design and single closure screw.
- When used with nipple this clamp is particularly adaptive for use on refrigeration or compressor piping subject to vibration.
- Interior design provides firm grip on pipe.
- Inside of ring tapered to prevent entrapment of condensed moisture.

Ordering: Specify pipe size, figure number, name and finish.

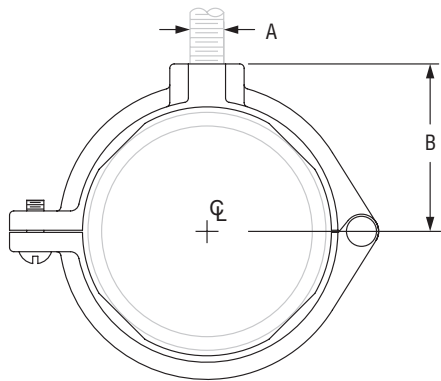

FIG. 138R: DIMENSIONS (IN) • LOADS (LBS) • WEIGHT (LBS)				
Pipe Size	Max Load	Weight	Rod Size A	B
3/8	180	0.10	3/8	13/16
1/2		0.13		7/8
3/4		0.14		1
1		0.16		1 1/8
1 1/4		0.22		1 5/16
1 1/2		0.24		1 7/16
2	300	0.31	1/2	1 11/16
2 1/2		0.60		2 1/8
3		0.74		2 7/16

PROJECT INFORMATION		APPROVAL STAMP	
Project:		<input type="checkbox"/> Approved	
Address:		<input type="checkbox"/> Approved as noted	
Contractor:		<input type="checkbox"/> Not approved	
Engineer:		Remarks:	
Submittal Date:			
Notes 1:			
Notes 2:			