

## Fig. 299

### Forged Steel Clevis

**Size Range:** 3/8" through 4"

**Material:** Forged steel

**Finish:**  Plain or  Galvanized

**Service:** For use on high temperature piping installations.

**Approvals:** Complies with Federal Specification A-A-1192A (Type 14), WW-H-171-E (Type 14), ANSI/MSS SP-69 and MSS SP-58 (Type 14).

**Features:**

- Available with pin and cotter pins, if required.

**Ordering:** Specify rod size, figure number, name and finish. If pin and cotter pins are required, specify "with pin". If other than standard combination of clevis number and rod size is required, specify clevis number, special rod tapping size, pin size, grip.

**Note:** The acceptability of galvanized coatings at temperatures above 450°F is at the discretion of the end user.

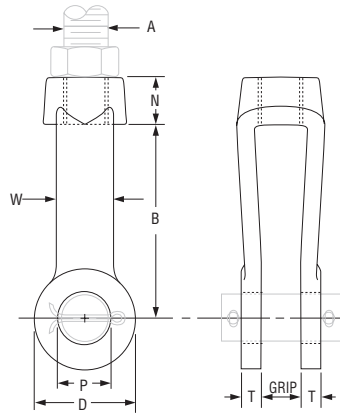

**FIG. 299: LOADS (LBS) • WEIGHTS (LBS) • DIMENSIONS (IN)**

Rod Size A	Max Load		Weight		Rod Take Out – B	D	N	Pin Dia. P	T	W	Grip	Clevis No.	
	650° F	750° F	Without Pin	With Pin									
3/8	730	572	0.9	1.0	3 1/16	1 7/16	5/8	1/2	5/16	1 1/16	1/2	2	
1/2	1,350	1,057	0.7	0.9				5/8			5/8		
5/8	2,160	1,692	0.7	0.9				3/4			3/4		
3/4	3,230	2,530	2.5	3.0	5	2	7/8	7/8	3/8	1 1/4	3/4	2 1/2	
7/8	4,480	3,508	2.5	3.4				1			1		
1	5,900	4,620	4.0	5.1				1 1/8			1 1/8		
1 1/4	9,500	7,440	3.8	5.5	6	3 1/2	1 5/8	1 3/8	1/2	1 1/2	1	3	
1 1/2	13,800	10,807	6.0	8.5				1 5/8			1 5/8		
1 3/4	18,600	14,566	8.0	12.9				1 7/8			1 7/8		
2	24,600	19,265	16.0	23.3	7	5	2 1/4	2 1/4	5/8	2 1/2	5	2 1/2	6
2 1/4	32,300	25,295	26.0	35.1	8	6	2 3/4	2 1/2	3/4	3			
2 1/2	39,800	31,169	25.5	36.0				2 3/4			2 3/4		
2 3/4	49,400	38,687	36.0	50.0	9	7	3	3	7/8	3 1/2	1 1/2	7	
3	60,100	47,066	35.0	51.5				3 1/4					3 1/4
3 1/4 •	71,900	56,307	90.0	116.0				3 1/2					3 1/2
3 1/2 •	84,700	66,331	88.0	118.0	10	8	4	3 3/4	1 1/2	4	4	8	
3 3/4 •	98,500	77,139	86.0	120.0				4					4
4 •	113,400	88,807	84.0	122.0				4 1/4					4 1/4

• Furnished with 8 UN series threads.

PROJECT INFORMATION		APPROVAL STAMP	
Project:		<input type="checkbox"/> Approved	
Address:		<input type="checkbox"/> Approved as noted	
Contractor:		<input type="checkbox"/> Not approved	
Engineer:		Remarks:	
Submittal Date:			
Notes 1:			
Notes 2:			