

PRODUCT MANUAL

SERIES 600
CHECK VALVE



AMERICAN

FLOW CONTROL

THE RIGHT WAY

INDEX



SERIES 600 SWING CHECK VALVE

	PAGE
INTRODUCTION	7C-2
FEATURES AND BENEFITS	7C-3
SPECIFICATIONS	7C-3
ORDERING	
Dimensions:	
Standard	7C-4
Lever and Weight	7C-5
Lever and Spring	7C-6
Optional Tap Locations	7C-7
Weights	7C-8
Submittal Sheet	7C-9
INSTALLATION AND MAINTENANCE	7C-10
REPAIRS	
Parts Lists:	
Standard	7C-11
Lever and Weight	7C-12
Lever and Spring	7C-13



WATEROUS SERIES 600 SWING CHECK VALVE

AMERICAN Flow Control's Waterous Series 600 Swing Check Valves are in full compliance with ANSI/AWWA C508 with a rated working pressure of 200 psig. Configurations are available that are UL Listed with a rated working pressure of 175 psig.

Waterous Series 600 swing check valves feature sturdy iron body and bronze mounted construction. This design provides extensive use of corrosion resistant materials in places where corrosion may be a problem.

SERIES 600 FEATURES AND BENEFITS



FEATURES AND BENEFITS

AMERICAN Flow Control's Waterous Series 600 Swing Check Valves are in full compliance with ANSI/AWWA C508 with a rated working pressure of 200 psig. Configurations are available that are UL Listed with a rated work-ing pressure of 175 psig.

The check valve is suitable for horizontal installation or vertical installation when the flow of water is in an upward direction.

Waterous Series 600 swing check valves feature sturdy iron body and bronze mounted construction. This design provides extensive use of corrosion resistant materials for installations where corrosion may be a problem.

RESILIENT SEATED DISC

The disc is constructed of high-strength bronze with a rubber seal recessed into the disc to assure a positive seal, even under low pressure.

Series 600 swing check valves are available in sizes 3 in. - 12 in. In addition to standard configurations, they are available with lever and spring or lever and weight for applications where rapid flow reversals may be encountered.

CORROSION RESISTANT

The clapper arm is made of high-strength bronze. The check valve disc and clapper arm assembly use corrosion resistant bearings, bushings and washers to reduce wear and assure long operating life.

FULL WATERWAY

These check valves are designed to provide a "Full Waterway" per MSS SP-71, Type I. Swing check valves with Full Waterway, when fully open, have waterway cross-sectional area at any point, that is at least equal to the area of a circle whose diameter is the nominal valve size.

AMERICAN Flow Control **Waterous Series 600 Swing Check Valves** have these features:

- Comply with ANSI/AWWA C508
- Stainless Steel Clapper Arm Shaft
- Full Waterway per Type I of MSS SP-71
- Bronze Clapper Arm
- Resilient Seated Disc
- Stainless Steel Body to Bonnet Bolting
- Available UL Listing
- Optional Fusion-Bonded Epoxy Coating Inside and Out
- Certified to NSF/ANSI Standard 61 and NSF/ANSI 372.

SPECIFICATIONS

Swing check valves shall be Waterous Series 600 by AMERICAN Flow Control. Check valves shall be manufactured from gray cast iron meeting or exceeding ASTM A126, Grade B. Check valves shall comply with ANSI/AWWA C508, latest revision, UL Listed and include the following features:

Check valves shall be designed with full waterway opening per Type I of MSS SP-71.

Check valve disc and clapper arm assembly shall be removable from the check valve body without having to remove the check valve from the pipeline.

All body to bonnet fasteners shall be Type 304 Stainless Steel.

Disassembly of valve internals shall require no special tools other than standard socket wrenches.

Check valve disc and clapper arm assembly shall be assembled using corrosion resistant bearings, bushings and washers to reduce wear and increase service life.

Clapper arm shall be constructed of high-strength bronze. Clapper arm shaft shall be stainless steel.

Disc shall be constructed of bronze with a Nitrile rubber seal recessed into the disc face to provide a positive seal against the mating bronze body seat ring.

In applications where slam surge may occur, check valves can be furnished with outside lever and weight or spring.

SERIES 600 - STANDARD DIMENSIONS

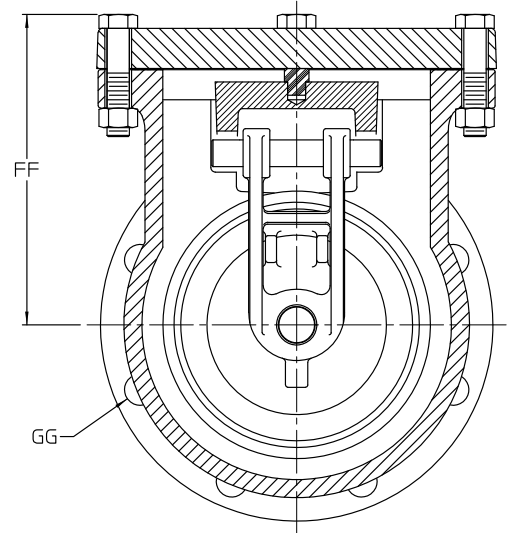
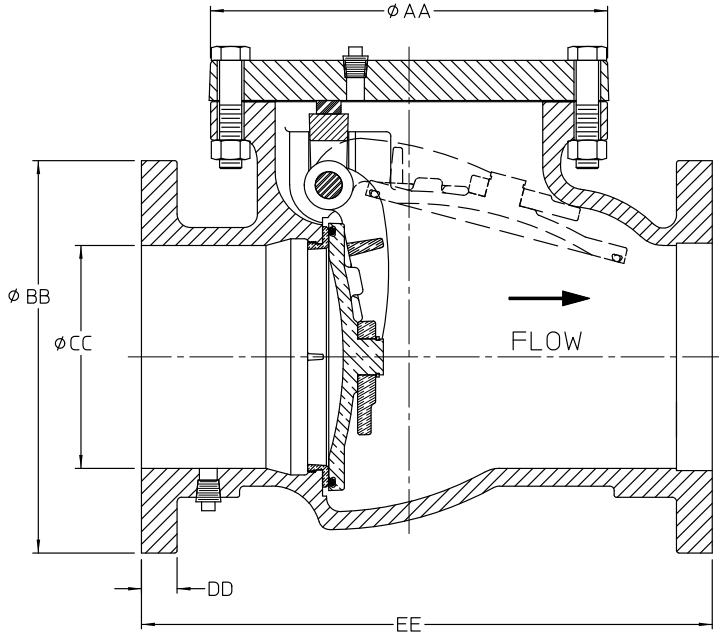

IL1456

Valve Size	AA	BB	CC	DD	EE	FF	GG		
							Holes	Size	Bolt Circle
3"	8.50	7.50	3.12	0.75	11.00	7.12	4	0.75	6.00
4"	8.38	9.00	4.12	0.94	13.00	6.81	8	0.75	7.50
6"	11.12	11.00	6.25	1.00	16.00	8.50	8	0.88	9.50
8"	14.00	13.50	8.12	1.12	19.50	10.19	8	0.88	11.75
10"	15.25	16.00	10.12	1.19	22.00	12.00	12	1.00	14.25
12"	18.00	19.00	12.12	1.25	26.00	12.38	12	1.00	17.00



**SERIES 600 - LEVER AND WEIGHT DIMENSIONS
(RIGHT HAND OUTSIDE SHAFT SHOWN)**

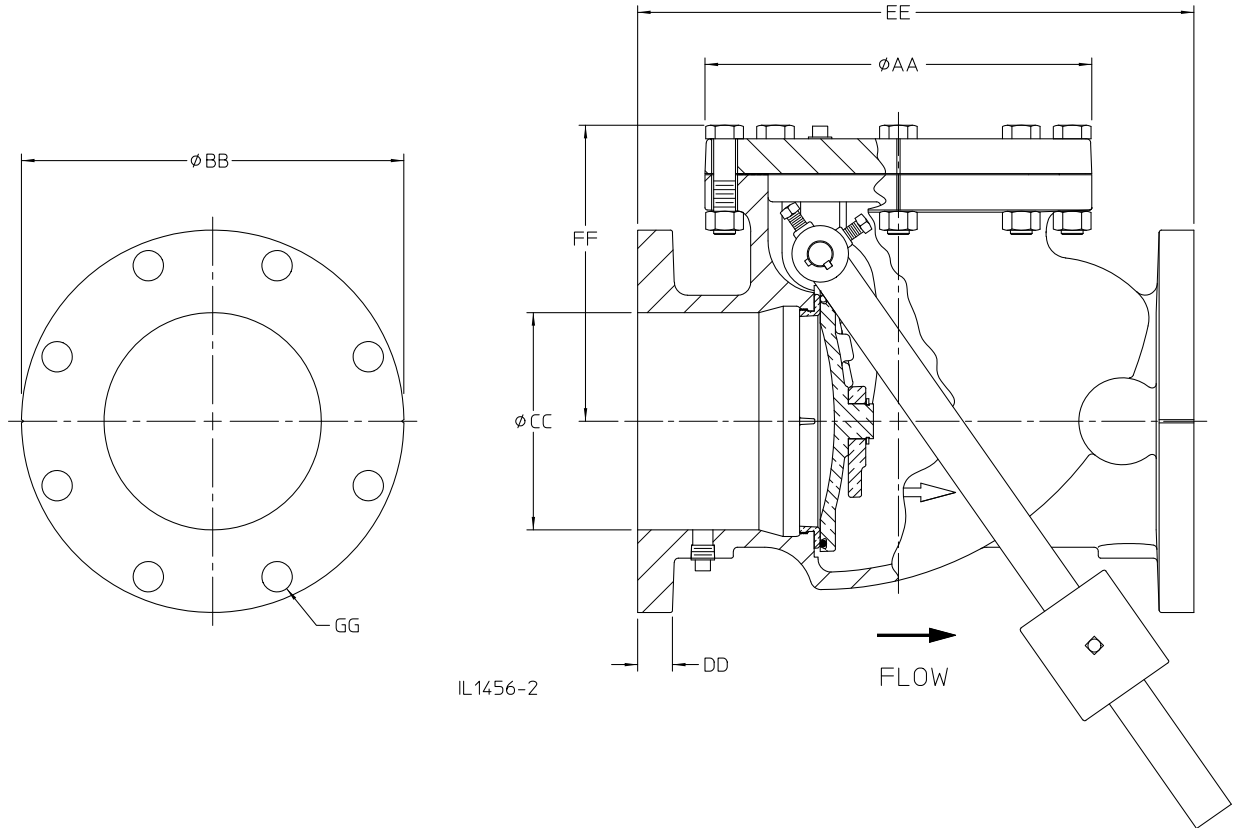

IL1456-2

Valve Size	AA	BB	CC	DD	EE	FF	GG		
							Holes	Size	Bolt Circle
3"	8.50	7.50	3.12	0.75	11.00	7.12	4	0.75	6.00
4"	8.38	9.00	4.12	0.94	13.00	6.81	8	0.75	7.50
6"	11.12	11.00	6.25	1.00	16.00	8.50	8	0.88	9.50
8"	14.00	13.50	8.12	1.12	19.50	10.19	8	0.88	11.75
10"	15.25	16.00	10.12	1.19	22.00	12.00	12	1.00	14.25
12"	18.00	19.00	12.12	1.25	26.00	12.38	12	1.00	17.00



**SERIES 600 - LEVER AND SPRING DIMENSIONS
(RIGHT HAND OUTSIDE SHAFT SHOWN)**

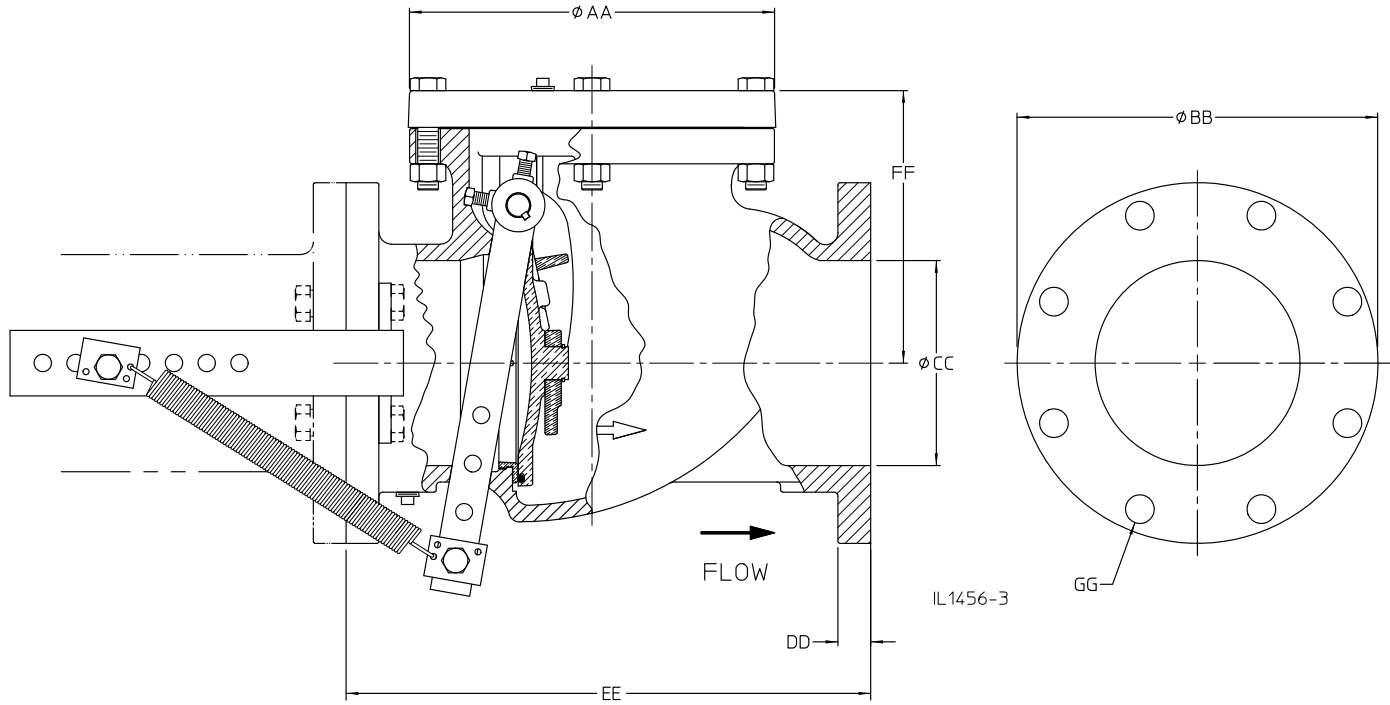

Valve Size	AA	BB	CC	DD	EE	FF	GG		
							Holes	Size	Bolt Circle
3"	8.50	7.50	3.12	0.75	11.00	7.12	4	0.75	6.00
4"	8.38	9.00	4.12	0.94	13.00	6.81	8	0.75	7.50
6"	11.12	11.00	6.25	1.00	16.00	8.50	8	0.88	9.50
8"	14.00	13.50	8.12	1.12	19.50	10.19	8	0.88	11.75
10"	15.25	16.00	10.12	1.19	22.00	12.00	12	1.00	14.25
12"	18.00	19.00	12.12	1.25	26.00	12.38	12	1.00	17.00

SERIES 600 - OPTIONAL TAP LOCATIONS

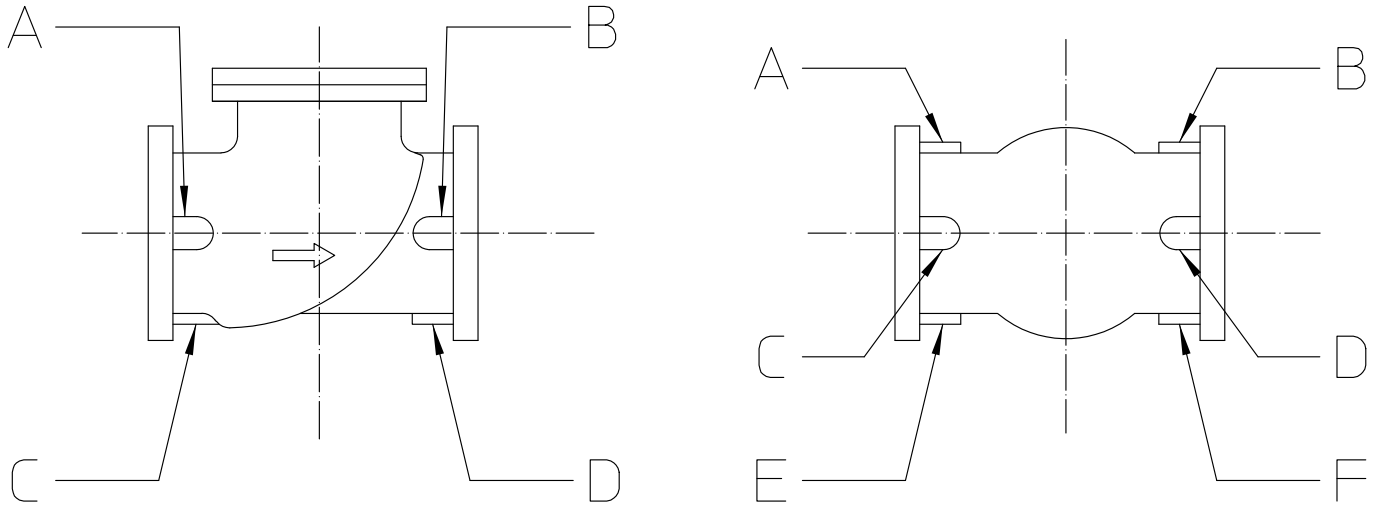

IL1456-1

Valve Size	Maximum Tap Size for Bosses	
	A, B, E & F	C, D
3"	3/4 NPT	3/4 NPT
4"	3/4 NPT	1/2 NPT
6"	1-1/4 NPT	3/4 NPT
8"	1-1/2 NPT	1/2 NPT
10"	2 NPT	3/4 NPT
12"	2 NPT	3/4 NPT

SERIES 600 - WEIGHTS



Valve Size	Standard	Lever / Spring or Weight
3"	60	70
4"	75	85
6"	145	160
8"	245	260
10"	380	405
12"	500	525

NOTE: All weights are in pounds.



INSPECTION ON DELIVERY

When shipment arrives, check for shortages, breakage, external damage, etc. Note all such claims on delivery ticket.

Any damage or shortage should be reported immediately to the truck driver, noted on the bill of lading and signed by the driver on your copy.

Carefully unload all valves - **DO NOT DROP.**

STORAGE

Valves are normally palletized when shipped which helps provide protection from weather during storage. If the pallet is disbanded and valves removed, remaining valves should be stored in an upright position with bulk-head flange on top or stored protected from the weather.

INSPECTION

Make sure the valve end flange gasket surfaces are clean and free of damage.

Clean inside of the valve to remove all contaminants that may affect water system purity. Check clapper O-ring. Check for free movement of clapper and seal fit.

INSTALLATION

Handle the valve carefully, check cover bolts for tightness. Ensure that the disc swings freely from closed to open and back again.

Be sure that the piping is properly supported to avoid stress on the valve. Make sure that the piping is properly aligned and spaced so the bolting of the valve in the line is not used to correct any errors in piping alignment or spacing.

Check valves should be installed in accordance with Standard Practice MSS SP-92.

Install valve with direction of flow arrows pointing in the direction the water will be flowing. Water flow must be horizontal or vertically upward through valve waterway.

To reduce check valve slamming, the valves supplied with the optional outside shaft configuration may be equipped with either a lever and weight or a lever and spring option. The principle behind these options is to close the check valve before the fluid establishes a reverse flow. The amount of closing torque required will vary with each system and can be adjusted by changing the number and position of the weights or springs.

Install lever and spring per instruction I-1043 for one spring and I-1044 for two springs. Optional three and four spring kits are available upon request.

The lever and weight arm has two keyways: one for valve waterway horizontal and one for valve waterway vertical.

MAINTENANCE

Normally there is no maintenance required on the check valve. If the valve begins to operate improperly, it may be necessary to remove the valve cover and inspect the internal disc and arm mechanism.

WARNING: Special care should be taken in the installation, inspection and repair of pressure containing devices such as valves and hydrants. FAILURE TO FOLLOW PROPER PRACTICE AND GUIDELINES CAN RESULT IN SERIOUS INJURY OR DEATH. Do not make repairs while check valve is under pressure.

Remove any debris that may be hung up in the valve and ensure that all moving parts operate freely before reassembling the valve. Repair or replace parts as necessary to return the valve to good working order.

GENERAL NOTES

These reference materials are available and should be helpful in the installation and testing of Swing Check Valves:

- ANSI/AWWA C508 - Swing Check Valves for Waterworks Service.

All installation, operation and maintenance instructions are issued by the manufacturer of the pipe and the valves.

- Valve user guide as published by MSS.
- NFPA-24 - Installation of Private Fire Service Mains and Their Appurtenances.

These industry practices have been listed to help you make a safe and acceptable installation of a swing check valve.

SERIES 600 - STANDARD PARTS LIST

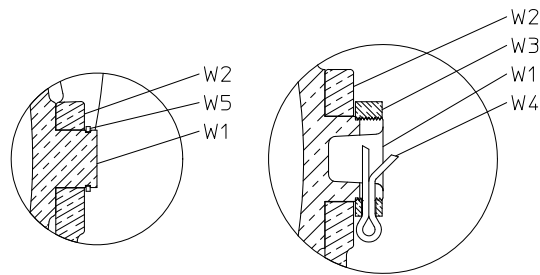
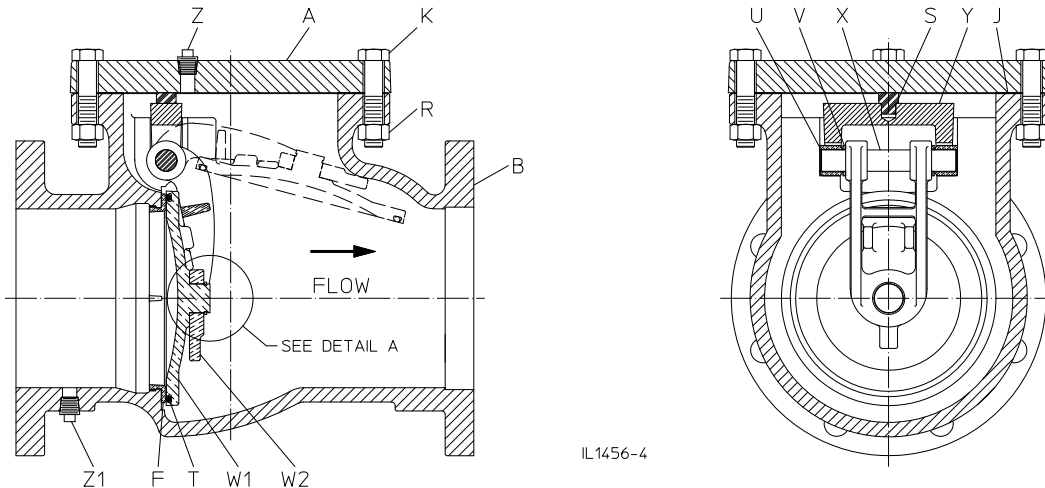

3" THRU 6" SIZES

8" THRU 12" SIZES

DETAIL A

Ref.	Description	Material
A	Cover	Gray Iron
B	Valve Body	Gray Iron
F	Body Seat Ring	Bronze
J	Cover Gasket	Synthetic Fiber with Elastomeric Rubber
K	Hex Head Bolt	Stainless Steel
R	Hex Nut	Stainless Steel
S	Bumper	Rubber
T	O-ring	Rubber
U	Bushing	Brass
V	Shim Washer	Brass
W1	Disc	Bronze
W2	Arm	Bronze
W3	Locknut	Bronze
W4	Cotter Pin	Stainless Steel
W5	Snap Ring	Stainless Steel
X	Shaft	Stainless Steel
Y	Yoke	Gray Iron
Z	Pipe Plug	Stainless Steel
Z1	Pipe Plug	Bronze

SERIES 600 - LEVER AND WEIGHT PARTS LIST

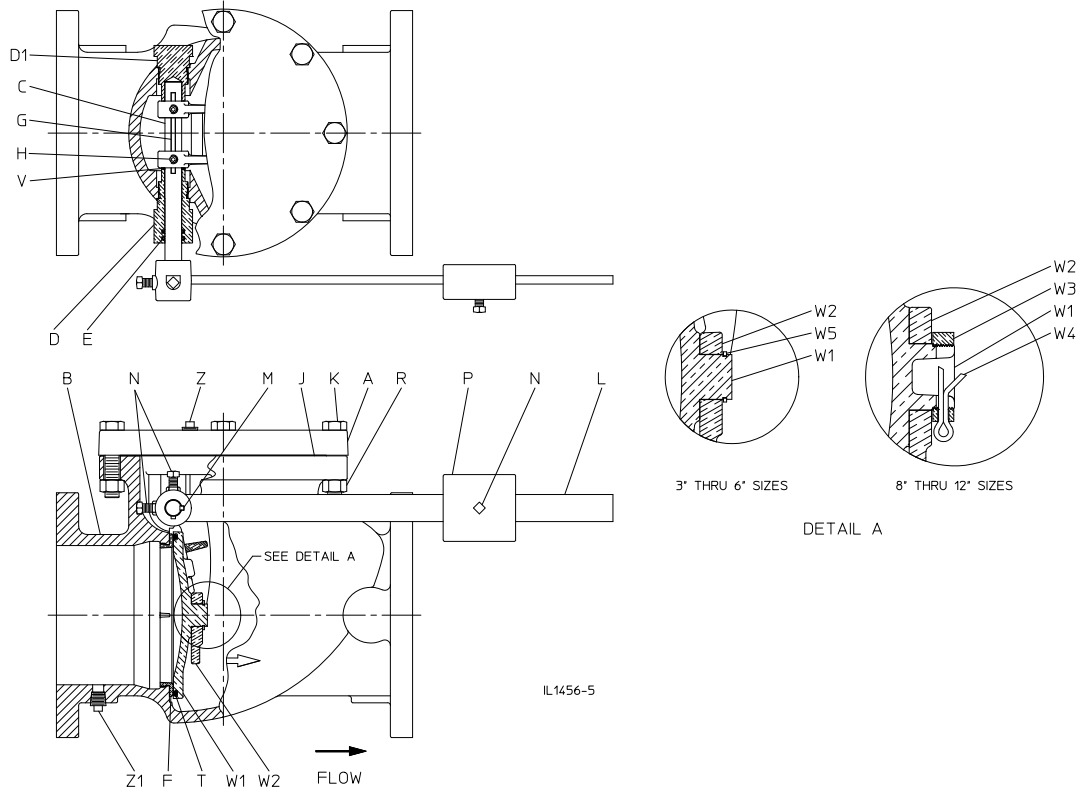

Ref.	Description	Material
A	Cover	Gray Iron
B	Valve Body	Gray Iron
C	Shaft	Stainless Steel
D	Shaft Support	Bronze
D1	Shaft Retainer	Bronze
E	O-ring	Rubber
F	Body Seat Ring	Bronze
G	Arm Key	Stainless Steel
J	Cover Gasket	Synthetic Fiber with Elastomeric Rubber
K	Hex Head Bolt	Stainless Steel
L	Weight Lever	Bronze
M	Lever Key	Stainless Steel
N	Square Head Set Screw	Steel
P	Weight	Gray Iron
R	Hex Nut	Stainless Steel
T	O-ring	Rubber
V	Shim Washer	Brass
W1	Disc	Bronze
W2	Arm	Bronze
W3	Locknut	Bronze
W4	Cotter Pin	Stainless Steel
W5	Snap Ring	Stainless Steel
Z	Pipe Plug	Stainless Steel
Z1	Pipe Plug	Bronze



SERIES 600 - LEVER AND SPRING PARTS LIST

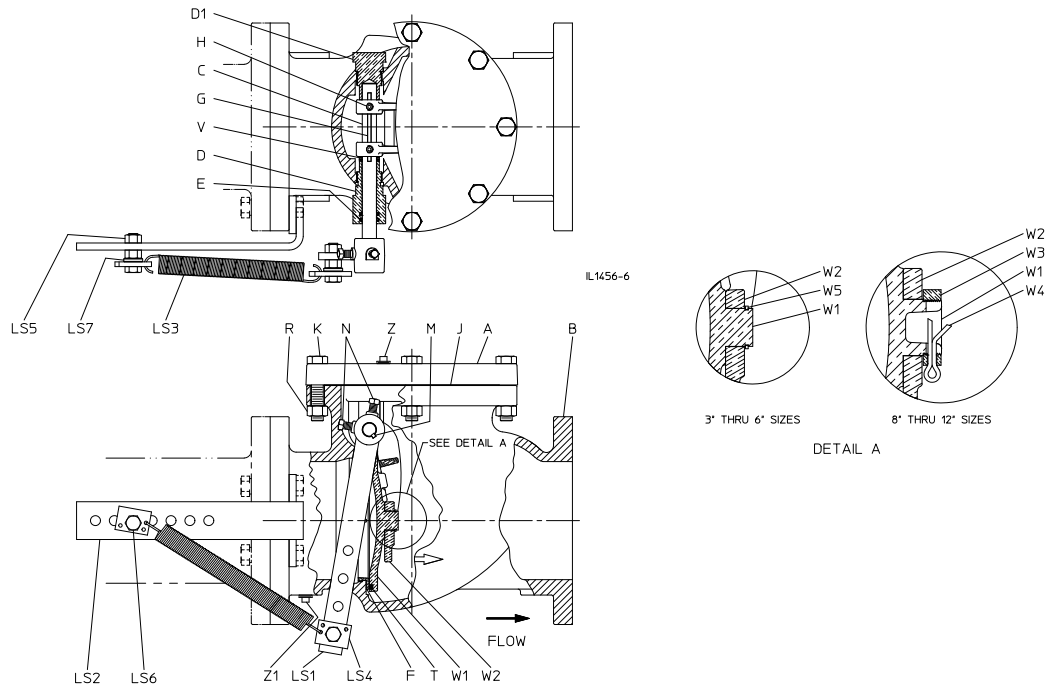

Ref.	Description	Material
A	Cover	Gray Iron
B	Valve Body	Gray Iron
C	Shaft	Stainless Steel
D	Shaft Support	Bronze
D1	Shaft Retainer	Bronze
E	O-ring	Rubber
F	Body Seat Ring	Bronze
G	Arm Key	Stainless Steel
H	Socket Head Set Screw	Steel
J	Cover Gasket	Synthetic Fiber with Elastomeric Rubber
K	Hex Head Bolt	Stainless Steel
LS1	Spring Lever	Bronze
LS2	Bracket	Steel
LS3	Spring	Stainless Steel
LS4	Spring Plate	Steel
LS5	Hex Nut	Plated Steel
LS6	Hex Head Bolt	Plated Steel
LS7	Spacer	Steel
M	Lever Key	Stainless Steel
N	Square Head Set Screw	Steel
R	Hex Nut	Stainless Steel
T	O-ring	Rubber
V	Shim Washer	Brass
W1	Disc	Bronze
W2	Arm	Bronze
W3	Locknut	Bronze
W4	Cotter Pin	Stainless Steel
W5	Snap Ring	Stainless Steel
Z	Pipe Plug	Stainless Steel
Z1	Pipe Plug	Bronze



AMERICAN

FLOW CONTROL

THE RIGHT WAY

AMERICAN Flow Control

P.O. Box 2727
Birmingham, AL 35202-2727
Phone: 800-326-8051
Fax: 800-610-3569
Email: afcsales@american-usa.com

Waterous Company

125 Hardman Avenue South
South St. Paul, MN 55075-2421
Phone: 888-266-3686
Fax: 800-601-2809
Email: afcsales@american-usa.com

WWW.AMERICAN-USA.COM



Product literature may become outdated. AMERICAN is not responsible for out-of-date information, errors or omissions.
Please contact AMERICAN for the most current product information.