

P420S Series SPEC SHEET

Swing Check Valve

Pressure Rating: 150 PSI @ 73° F
 Max. Temperature: 140° F

Corrosion Resistant.
 Angle seat and weighted flapper design for low pressure seal.
 Ideal for tight working spaces, easy pipe alignment.
 Directional arrow on the body.
 Horizontal or vertical applications.
 Not recommended for service or test with compressed air or gasses.



Swing Check Valves	Body	Style	Ends	Seats	Seals
P420S	Sch 80 PVC	Swing Check	Socket	PTFE	EPDM
P430S	Sch 80 PVC	Foot Swing Check	Socket	PTFE	EPDM

Size	3"	4"
Ød1	3.52	4.52
Ød2	3.49	4.49
Ød3	4.25	5.24
ØD	7.72	8.27
ØD1	5.98	7.52
ØD3	6.02	6.02
L1	8.70	10.67
L3	10.83	12.60
I	1.88	2.25
Cv(P420S)	285	490

The Cv Factor is the gallons of water per minute passed through the valve, with a 1 PSI pressure drop.

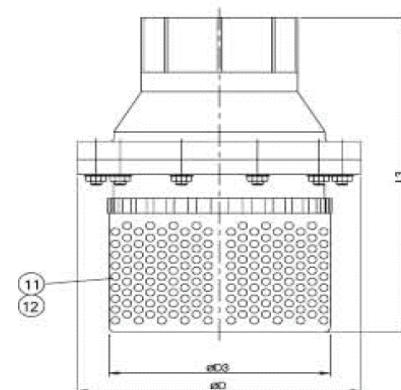
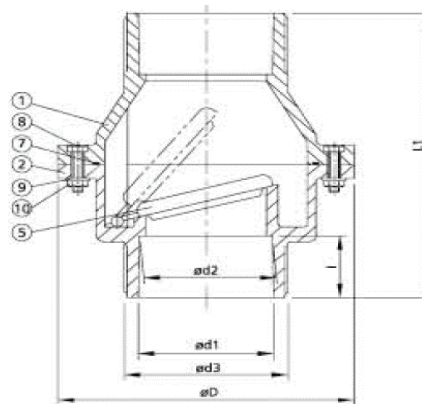

MATERIALS

NO.	PART	MATERIALS	QTY
1	Upper Body	PVC	1
2	Lower Body	PVC	1
5	Disc	EPDM	1
7	O-Ring	PVC	1
8	Bolts	SUS 304	10
9	Washer	SUS 304	10
10	Nut	SUS 304	10
11	Screen	PVC	1



DATE: