

NOTE: Replacement parts manual for Models RIH and TRP has been revised to Form RZ-NA-P-VR/TRP/RIH

IMPORTANT

1. Always include complete heater model and serial number so that any specification change can be considered for parts shipment. It can save time and expense.
2. Specifications are subject to change without notice.
3. We reserve the right to substitute functional replacements
4. Order by Part Number. **Do not** order by Option Number.

REZNOR *Thomas & Betts*

INFRARED HEATERS

Replacement Parts Form RZ-NA-P-TR
Obsoletes Form 709 (Version B)

APPLIES TO: INFRA-REZ™ Heater Models TR/TR-H and TRP and Models RIH/RIHV

INDEX by Model Replacement parts on pages	TR/TR-H	TRP	RIH/RIHV
	4-8, 13-14	9-14	15-16
Burner Assembly	5	11	16
Burner/Control Box and Components	4	9	--
Capacitor	5	9	--
Chains for Hanging	13	11	15
Combustion Chamber Tube	7	--	--
Connector, Flexible Gas	13-14	13-14	15
Conversion Kit, Altitude	8	--	--
Conversion Kit, Gas	8	12	--
Cord, Power	6	11	--
Door Assembly (Burner Box)	4	9	--
Electric Components	6	10-11	15
Heat Exchanger/Reflector Assembly	--	11	--
Heat Exchanger Tube (5-ft) (Same as Option UA1)	7	--	--
Heat Exchanger Tube (10-ft)	7	--	--
Ignition Controller	6	10	15
Inlet Air Kit (Combustion Air, Same as Option DE2)	13	--	--
"L" Heat Exchanger Tube (Same As Option UC2)	8	--	--
Light (Burner Indicator)	6	--	--
Manifold	5	11	16
Motor	5	9	--
Multiple Heater Control (Same as Options CL31/32)	13-14	--	--
Orifice, Air (Combustion Air Restrictor Plate)	4	--	--
Orifice, Gas	5	12	16
Pilot	7	--	15
Rating Plate/Model Conversion Label	2 & 3	2 & 3	--
Reflector	7	11	16
Reflector End Cap	7	--	--
Reflector Gap Cover	7-8	--	--
Reflector Retainer Kit	7	--	--
Relay, Time Delay	6	--	--
Replacement Parts Tag	3	3	--
Restrictor Plate	4	--	--
Screen, Protective (Same as Option DN3)	--	--	16
Separated Combustion Air/Vent Terminal Kits (Same as Options CC2 & CC6)	--	12	--
Serial No.	2 & 3	2 & 3	--
Shield, Heat (Same as Option DO3)	--	--	16
Shield, Side (Same as Options CD13-20, 30-31)	13-14	13-14	--
Switch, Door	6	--	--
Switch, Air Pressure	6	10	--
Transformer	6	10	--
Thermostat/Thermostat Accessories	13	13	15
Tube Connection Hardware	7	11	--
Tube Packages	7	--	--
Turnbuckle	13	13	--
"U" Heat Exchanger Tube (Same as Option UB3)	7-8	--	--
Valve	6	10	15
Vent Cap	4	--	--
Vent Kit for Dual Vent (Same as Option CC5)	13	13	--
Wire Grid (Same as Option DN2)	--	--	16

INFRA-REZ™ Model, Low-Intensity, Tubular, Infrared Heaters



TR/TR-H Tubular Radiant Heaters



TRP Tubular Radiant Packaged Heater

Models RIH/RIHV High-Intensity Infrared Heaters

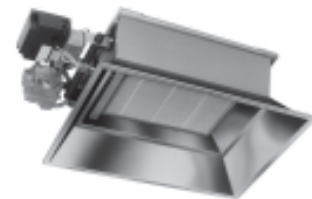

REFERENCES:

Form RGM

450, Model RIH/RIHV Installation/Maintenance

452, Model TRP Installation/Operation/Maintenance

452-GC, Model TRP Gas Conversion

456, Model TR/TR-H Installation



456-OMS, Model TR/TR-H Maintenance and Service

456-GC, Model TR Gas Conversion

456-HA, Model TR High Altitude Conversion

Rating Plate and Serial No.

(Example is a Model TRP)

REZNOR		 
MERCER, PA. USA 16137		
MADE IN MEXICO / FABRIQUÉ AU MEXIQUE		
TUBULAR INFRARED HEATER		
FOR INDUSTRIAL / COMMERCIAL USE ONLY POUR USAGE INDUSTRIEL / COMMERCIAL SEUL		
ANSI Z83.6b- [A] CAN/CGA-2.16-M [A'] INFRARED HEATER		
MODEL/DATE	MODÈLE/DATE	[B] [C]
SERIAL NO.	#DE SÉRIE	[]
TYPE OF GAS	TYPE DE GAZ	[E]
VOLTS/PH/HZ	VOLTS/PH/HZ	[D]
MAX. TOTAL AMPS	TOTALE MAX. DE AMPERAGE	[K]
ALTITUDE	ALTITUDE	[F] FEET [G] METERS
GAS ORIFICE SIZE	DIMENSION DE GAZ L'ORIFICE	[H] DRILL/FORET
NORMAL INPUT	ENTRÉE NORMALE	[I] BTUH
ALT. ADJ. NORMAL INPUT	ALT. ADJ. ENTRÉE NORMALE	[Q] BTUH
MANIFOLD PRESSURE	PRESSION DE LA TUB	[O] IN. W.C./PO/COL D'EAU
MIN. PERMISSIBLE GAS SUPPLY PRESSURE FOR PURPOSE OF INPUT ADJUSTMENT: [P] IN. W.C.		
CLEARANCES TO COMBUSTIBLE CONSTRUCTION:		
TOP- [X] INCHES; SERVICE SIDE- [Y] INCHES; OPPOSITE SIDE [Z] INCHES; FLUE CONNECTION - 6 INCHES; BELOW- [W] INCHES		
REFLECTOR	MAX. MOUNTING ANGLE	BELOW FRONT/REAR
STANDARD	0 DEGREES	[W]" [S]"
STANDARD	45 DEGREES	[W]" [T]"
STANDARD W/SIDE SHIELDS	[R] DEGREES	[W]" [U]"
* 24" IF UNVENTED		
THIS UNIT IS FOR USE WITH NATURAL OR PROPANE GAS. A CONVERSION KIT, AS SUPPLIED BY THE MANUFACTURER, SHALL BE USED TO CONVERT THIS HEATER TO THE ALTERNATE FUEL.		
FOR ALTERNATE INSTALLATIONS USE THE LATEST ADDITIONS OF THE APPROPRIATE STANDARDS LISTED BELOW:		
STANDARD ON AIRCRAFT HANGARS:	ANSI/NFPA 409	
STANDARD ON PARKING STRUCTURES:	ANSI/NFPA 88A	
STANDARD ON REPAIR GARAGES:	ANSI/NFPA 88B	
PRES. D'ALIM MIN. ACCEPTABLE DE GAZ POUR DES FIN DE RÉGLAGE DE L'ENTRÉE: [P] PO/COL D'EAU		
DÉGAGEMENT ENTRÉE LES CONSTRUCTIONS COMBUSTIBLES:		
EN HAUT- [X] PO; CÔTÉ ENTRETIEN [Y] PO; CÔTÉ OPPOSÉ [Z] PO; EN BAS- [W] PO; RACCORD DE TUYAUX- 6 PO		
CET APPAREIL POUR UTILISATION AVEC LE GAZ NATUREL OU LE PROPANE. UNE TROUSSE DE CONVERSION FOURNIE PAR LE FABRICANT DOIT ÊTRE UTILISÉ POUR PASSER D'UN COMBUSTIBLE À L'AUTRE. L'INSTALLTION DE L'UNITÉ DANS DES GARAGES D'AVIONS DOIT SE CONFORMER AUX		
CONDITIONS DES AUTORITÉS CHARGÉE DE FAIRE APPLIQUER LA LOI. L'INSTALLATION DANS DES GARAGES PUBLICS DOIT SE CONFORMER AU CODE CAN/CGA-B149 (.1 OU .2).		
SEPARATED COMBUSTION UNITS MUST USE THE CONCENTRIC ADAPTER ASSEMBLY LISTED IN THE MANUFACTURER'S INSTALLATION INSTRUCTIONS. CONSTRUCTION WALL THICKNESS FOR PURPOSE OF VENTING: 1" MINIMUM, 30" MAXIMUM		

Key:

- A** Design Standards (ANSI Z83.6B and CGA 2.16-M)
- B** Model No.
(Model Suffixes: H - High altitude; DP - Separated combustion; WP - Outdoor unit)
- C** Mfg Date (month and year)
- D** Supply Voltage
- E** Type of Gas (Natural or Propane)
- F** Altitude (feet)
- G** Altitude (meters)
- H** Orifice Size
- I** Normal Sea Level Input (BTUH)
- K** Maximum Total Amps
- O** Normal Manifold Pressure ("w.c.)
- P** Minimum Gas Supply Pressure
- Q** High Altitude Input (BTUH)
- R** Maximum Mounting Degrees with Side Shield
- S** Front/Rear Clearances (Horizontal Mounting)
- T** Front/Rear Clearances (Angled up to 45°)
- U** Front/Rear Clearances with Side Shield
- W** Clearance Below
- X** Clearance Above
- Y** Clearance on Service Side
- Z** Clearance on Other Side

Serial No.

Example:

AZA	71	T9	N	12345
1	2	3	4	5

Codes:

- 1 = Date of manufacture (see chart on page 3)
- 2 = Type of ignition
- 3 = Type of valve
- 4 = Type of gas (N= Natural; L= Propane)
- 5 = Consecutive number (for identification purposes only)

First Element of the Serial Number - Date of Manufacture

Year	Jan	Feb	Mar	Apr	May	June	July	Aug	Sept	Oct	Nov	Dec
1992	ARA	ARB	ARC	ARD	ARE	ARF	ARG	ARH	ARI	ARJ	ARK	ARL
1993	ASA	ASB	ASC	ASD	ASE	ASF	ASG	ASH	ASI	ASJ	ASK	ASL
1994	ATA	ATB	ATC	ATD	ATE	ATF	ATG	ATH	ATI	ATJ	ATK	ATL
1995	AUA	AUB	AUC	AUD	AUE	AUF	AUG	AUH	AUI	AUJ	AUK	AUL
1996	AVA	AVB	AVC	AVD	AVE	AVF	AVG	AVH	AVI	AVJ	AVK	AVL
1997	AWA	AWB	AWC	AWD	AWE	AWF	AWG	AWH	AWI	AWJ	AWK	AWL
1998	AXA	AXB	AXC	AXD	AXE	AXF	AXG	AXH	AXI	AXJ	AXK	AXL
1999	AYA	AYB	AYC	AYD	AYE	AYF	AYG	AYH	AYI	AYJ	AYK	AYL
2000	AZA	AZB	AZC	AZD	AZE	AZF	AZG	AZH	AZI	AZJ	AZK	AZL
2001	BAA	BAB	BAC	BAD	BAE	BAF	BAG	BAH	BAI	BAJ	BAK	BAL
2002	BBA	BBB	BBC	BBD	BBE	BBF	BBG	BBH	BBI	BBJ	BBK	BBL
2003	BCA	BCB	BCC	BCD	BCE	BCF	BCG	BCH	BCI	BCJ	BCK	BCL
2004	BDA	BDB	BDC	BDD	BDE	BDF	BDG	BDH	BDI	BDJ	BDK	BDL
2005	BEA	BEB	BEC	BED	BEE	BEF	BEG	BEH	BEI	BEJ	BEK	BEL
2006	BFA	BFB	BFC	BFD	BFE	BFF	BFG	BFH	BFI	BFJ	BFK	BFL
2007	BGA	BGB	BGC	BGD	BGE	BGF	BGG	BGH	BGI	BGJ	BGK	BGL
2008	BHA	BHB	BHC	BHD	BHE	BHF	BHG	BHH	BHI	BHJ	BHK	BHL
2009	BIA	BIB	BIC	BID	BIE	BIF	BIG	BIH	BII	BIJ	BIK	BIL
2010	BJA	BJB	BJC	BJD	BJE	BJF	BJG	BJH	BJI	BJJ	BJK	BJL
2011	BKA	BKB	BKC	BKD	BKE	BKF	BKG	BKH	BKI	BKJ	BKK	BKL
2012	BLA	BLB	BLC	BLD	BLE	BLF	BLG	BLH	BLI	BLJ	BLK	BLL
2013	BMA	BMB	BMC	BMD	BME	BMF	BMG	BMH	BMI	BMJ	BMK	BML
2014	BNA	BNB	BNC	BND	BNE	BNF	BNG	BNH	BNI	BNJ	BNK	BNL
2015	BOA	BOB	BOC	BOD	BOE	BOF	BOG	BOH	BOI	BOJ	BOK	BOL

Size Conversion Label - Models TR 75, 125, 175

When servicing a heater with a rating plate reading Model TR75, TR125, or TR175, always look for a Size Conversion label.

- **Rating Plate reads Model TR75/ Size Conversion Label reads TR100** - Burner/control boxes originally ordered as Model TR-A or Model TR75/100 include a factory-built Model TR75 and a field kit to convert to a Model TR100. A heater with Model TR75 rating plate and a Field Conversion Label converting it to a Model TR100 is the same as a factory-built Model TR100.
- **Rating Plate reads Model TR125/ Size Conversion Label reads TR150** - Burner/control boxes originally ordered as Model TR-C or Model TR125/150 include a factory-built Model TR125 and a field kit to convert to a Model TR150. A heater with Model TR125 rating plate and a Field Conversion Label converting it to a Model TR150 is the same as a factory-built Model TR150.
- **Rating Plate reads Model TR175/ Size Conversion Label reads TR200** - Burner/control boxes originally ordered as Model TR-K or Model TR175/200 include a factory-built Model TR175 and a field kit to convert to a Model TR200. A heater with Model TR175 rating plate and a Field Conversion Label converting it to a Model TR200 is the same as a factory-built Model TR200.

Example of a Size Conversion Label

<p>This appliance has been converted at the time of installation to a Model 100 with Kit No. 120096 by _____ who accepts the responsibility for the correctness of this conversion.</p>	
<p>ORIFICE SIZE - #12 drill NORMAL INPUT - 100,000 btu/hr</p>	<p>Minimum permissible gas supply pressure for purposes of input adjustment - 4.5" w.c.</p>

Example of a Replacement Parts Tag

Replacement parts tags on Model TR/TR-H and TRP heaters are for your convenience in identifying replacement part numbers. Always give the complete Model No., Serial No., and P/N with description when ordering replacement parts.

COMMON REPLACEMENT PARTS FOR: REZNOR	
MODEL TR75	
SERIAL NUMBER	ARI66M4N44585
WHEN ORDERING PART, ALWAYS GIVE THE FULL MODEL NUMBER AND SERIAL NUMBER	
TRANSFORMER	102709
PILOT	097534
SPARK IGNITION	097782
TIME DELAY RELAY	116044
BLOWER MOTOR	097738
BLOWER WHEEL	097724
PRESSURE SWITCH	120031
BURNER DOOR SWITCH	116023
BURNER ON LIGHT	116045
OPTIONAL REPLACEMENT PARTS:	
4" INLET AIR CAP	120724
-- WARNING --	
ALL PARTS ARE FOR USE WITH THE FUEL IDENTIFIED ON THE UNIT RATING PLATE. IF THE UNIT HAS BEEN CONVERTED TO OTHER FUELS, CHECK WITH DEALER FOR PROPER FUEL-CARRYING PARTS. INSTALLATION OF IMPROPER PARTS CAN CAUSE DEATH OR INJURY OR PROPERTY LOSS.	

Burner/Control Box - Models TR/TR-H (Model TR-H is a for operation at elevations above 2000 ft. Unless specified, replacement parts apply to Both Model TR and TR-H)

Burner/Control Box and Non-Operating Components

Code	Description	Qty (other than 1)	50	75	100	125	150	175	200	
1	Burner Control Box	Gas Natural	Ignition System Recycling Spark	125791	115953	120521	120297	120523	133246	133248
		Natural	Spark with Lockout	150000	150001	150002	150003	150004	150005	150006
		Propane	Spark with Lockout	125797	115997	120522	120298	120524	--	--
2	Burner Box Hanger	2	116030	116030	116030	116030	116030	116030	116030	
3	Burner Box Door Assembly		125794	115964	115964	115964	115964	115964	115964	
4	Draw/Pull Door Latch, Guden #832-02	2	120735	120735	120735	120735	120735	120735	120735	
5	Combustion Air Inlet Cover Assembly		116040	116040	116040	116040	116040	133253	133253	
6	Hardware Bag for attaching Burner/Control Box and Combustion Chamber Tube (includes 4 lockwashers, 4 nuts, 3 "S" hooks, 1 gasket (Code 6A), 2 bolts, 4 screws)		120348	120348	120348	120348	120348	120348	120348	
6A	Combustion Chamber/Burner Box Gasket		116029	116029	116029	116029	116029	116029	116029	
7	Hole Plug for Testing Port, Heyco #DP-875 (replaces P/N 120350)		16452	16452	16452	16452	16452	16452	16452	
8	Vent Cap, 4"		110051	110051	110051	110051	110051	110051	110051	
9	Combustion Air Restrictor Plate (also referred to as an air orifice plate)									
	Natural Gas, 0-2000 Ft Elevation (Model TR)	U.S. & Canada	125795	120354	120546	120355	120547	133166	133167	
	Propane Gas, 0-2000 Ft Elevation (Model TR)	U.S. & Canada	125795	120529	120546	120355	120547	--	--	
	Natural, 2001-4000 Ft (Model TR-H)	U.S. (ANSI Std)	126072	120381	120382	120383	120384	133802	133803	
	Propane, 2001-4000 Ft (Model TR-H)		126072	120381	120382	120383	120384	--	--	
	Natural, 4001-6000 Ft (Model TR-H)		126075	120981	120982	120983	120984	133807	133808	
	Propane, 4001-6000 Ft (Model TR-H)		126075	120981	120982	120983	120984	--	--	
	Natural, 6001-8000 Ft (Model TR-H)		126081	120985	120986	120987	120988	133810	--	
	Propane, 6001-8000 Ft (Model TR-H)		126081	120985	120986	120987	120988	--	--	
	Natural, 2001-4500 Ft (Model TR-H)	Canada	126072	120381	120382	120383	120384	133802	133803	
Propane, 2001-4500 Ft (Model TR-H)	(CGA Std)	126072	120381	120382	120383	120384	--	--		
10	Sensing Tube with Bracket		115969	115969	115969	115969	115969	115969	115969	
11	Pilot Mounting Bracket with Sensing Rod		120675	120675	120675	120675	120675	120675	120675	

Code 1 - Burner/Control Box

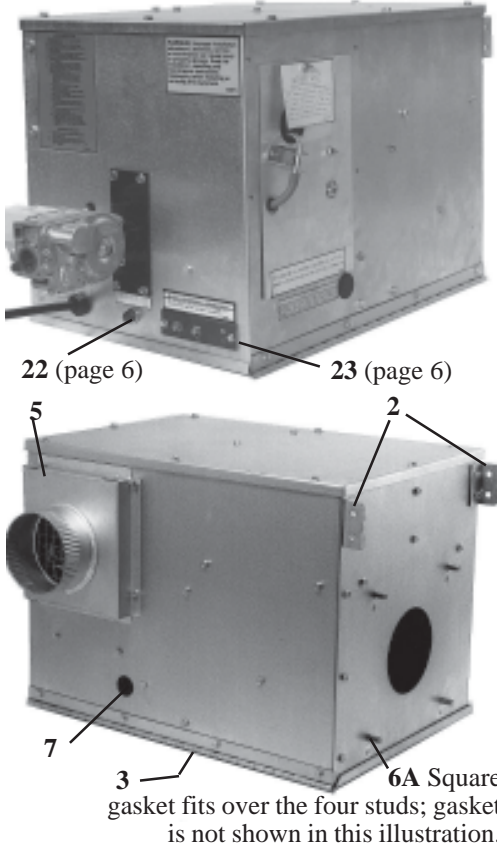

Code 4 - Door Latch



Code 8 - 4" Vent Cap



Codes 9 and 10

9 - Combustion Air Restrictor Plate

10 - Combustion Air Flow Sensor Bracket and Tube

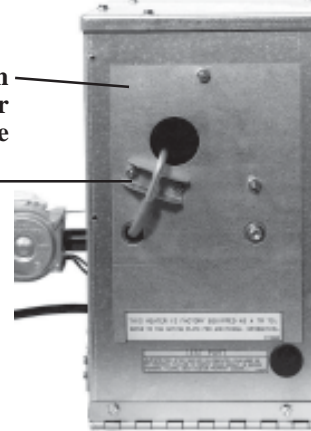

Code 11 - Pilot Mounting Bracket with Ground Rod

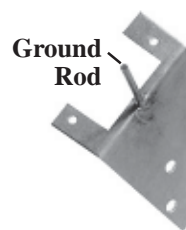

Burner/Control Box Top View (with Top Panel Removed)

14A/B - Combustion Air/Venter Motor and Wheel Assembly

14C 14D

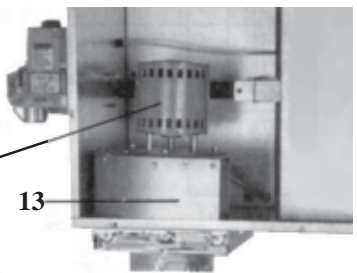

Code 14E - Capacitor



Combustion Air/Venter Blower and Motor (Model TR operates at 0-2000 ft elevation; Model TR-H above 2000 ft)

Code	Description	Model	50	75	100	125	150	175	200
13	Blower Housing	TR	120999 Hi-Tech #360	120999 Hi-Tech #360	120999 Hi-Tech #360	120999 Hi-Tech #360	121861	132006	132006
		TR-H	120999 Hi-Tech #360	120999 Hi-Tech #360	120999 Hi-Tech #360	121575	121575	132006	132006
14	Combustion Air/Venter Mtr & Wheel Assy (includes Codes 14A-G)	TR	116002	116002	116002	116003	116003	132009	132009
		TR-H	116002	116002	116002	121052	121052	132009	132009
14A	Motor - 115 Volt	TR & TR-H	97738 Universal #JAIM156M	97738 Universal #JAIM156M	97738 Universal #JAIM156M	97741 Universal #JEIE009N	97741 Universal #JEIE009N	132058 Universal #JE1F015N	132058 Universal #JE1F015N
14B	Motor - 208/230 Volt	TR & TR-H	98157 Universal #JEIE010N	98157 Universal #JEIE010N	98157 Universal #JEIE010N	98157 Universal #JEIE010N	98157 Universal #JEIE010N	98157 Universal #JEIE010N	98157 Universal #JEIE010N
14C	Venter Wheel	TR	97724 Brookside #FE-400-200	97724 Brookside #FE-400-200	97724 Brookside #FE-400-200	97724 Brookside #FE-400-200	97724 Brookside #FE-400-200	132007 Brookside #FE-610-216-1	132007 Brookside #FE-610-216-1
		TR-H	97724 Brookside #FE-400-200	97724 Brookside #FE-400-200	97724 Brookside #FE-400-200	120545 Brookside #FE-519-119-2	120545 Brookside #FE-519-119-2	132007 Brookside #FE-610-216-1	132007 Brookside #FE-610-216-1
14D	Motor Plate	TR	97301	97301	97301	97301	97301	132019	132019
		TR-H	97301	97301	97301	120997	120997	132019	132019
14E	Motor Capacitor - 4MFD @ 370V	TR & TR-H	--	--	--	163894	163894	163894	163894
14F	Capacitor Boot - Syntex #M-78	TR & TR-H	--	--	--	103182	103182	103182	103182
14G	Spacers - #8 Spirol	TR & TR-H	(4)97721 3/4"lg	(4)97721 3/4"lg	(4)97721 3/4"lg	(4)97722 15/16"lg	(4)97722 15/16"lg	(4)97722 15/16"lg	(4)97722 15/16"lg

Burner, Manifold and Orifices

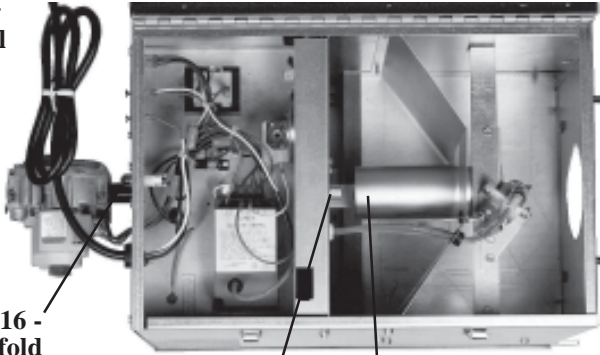

Burner Control Box

16 - Manifold

17 - Burner Orifice

15 - Burner Assembly



Code 15 - Main Burner Assembly



Code 16 - Manifold



Code 17 - Burner Orifice

Select burner orifice carefully. Do not ream.

Code	Description	Model	50	75	100	125	150	175	200		
15	Main Burner Assembly	TR/TR-H	115973	115973	115973	115973	115973	132022	132022		
16	Manifold & Manifold Bracket	TR/TR-H	115981	115981	115981	115981	115981	115981	115981		
17	Burner Orifice	Natural	0-2000 ft	TR	120146 3.4mm	120153 #20	120157 #12	120161 #1	120165 D	120164 C	136200 6.75mm
		Propane	0-2000 ft	TR	124966 #45	120137 #40	120141 #32	120145 3.3mm	120149 #27	--	--
	Burner Orifice (Do not use for high altitude conversion; high altitude kits are on page 8.)	Natural	2001-4000 ft	TR-H	120147 #29	120154 #19	120158 #10	131581 5.9mm	120166 E	120165 D	136201 6.8mm
		Propane	2001-4000 ft	TR-H	124967 2.1mm	120138 #39	120142 #3.0mm	120145 3.3mm	120150 #26	--	--
		Natural	4001-6000 ft	TR-H	124969 #28	131579 4.25mm	120159 5.0mm	120162 A	120167 F	120166 E	136202 7.0mm
		Propane	4001-6000 ft	TR-H	124968 2.15mm	120139 #38	120143 #31	120146 3.4mm	120151 3.8mm	--	--
		Natural	6001-8000 ft	TR-H	120149 #27	120155 #18	131580 #8	120164 C	120168 G	120167 F	--
		Propane	6001-8000 ft	TR-H	131578 2.2mm	120140 #37	120144 3.1mm	120148 3.5mm	120152 #23	--	--

Burner/Control Box (cont'd)

Electrical Components

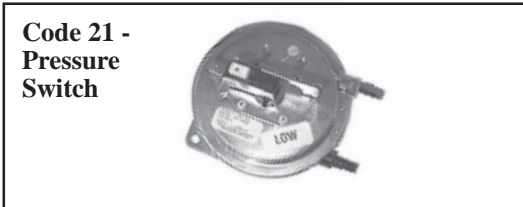
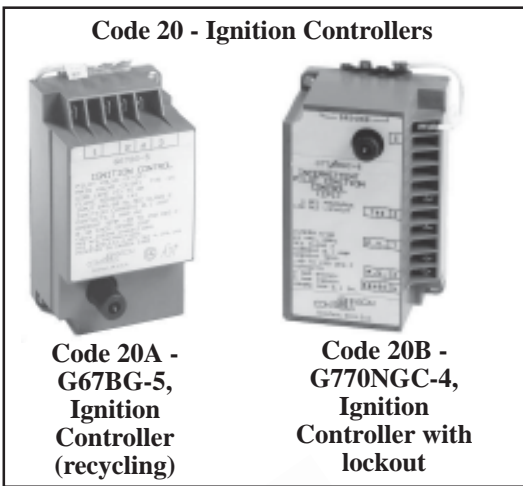
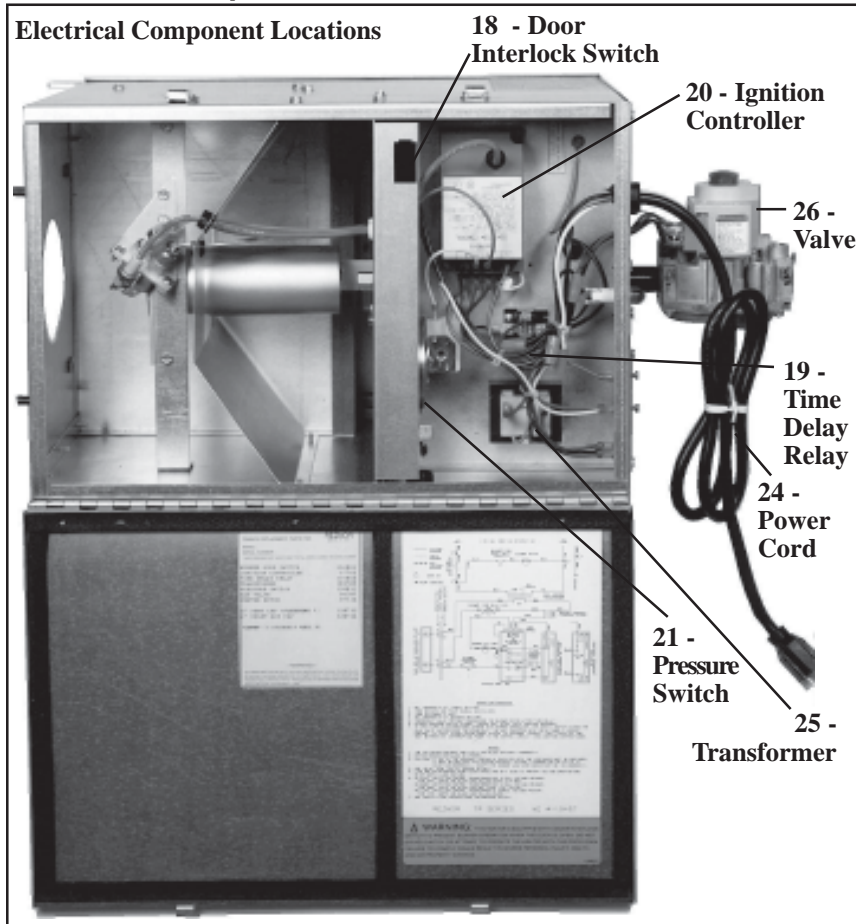

Code	Description	Application	P/N
18	SPST Switch (Door Interlock Switch), MCG 0815-9011	All Sizes	116023
19	Time Delay Relay, 24V, T.I. #60704A0-41	All Sizes	116044
20A	Ignition Controller - Model G67BG-5	All Sizes	97782
20B	Ignition Controller with lockout - Model G770NGC-4	All Sizes (required w/propane)	97547
21	Pressure Switch, Tri-Delta #PPS10138-2813	All Sizes 0-2000 ft elevation; Sizes 50-150 - 2001-6000 ft; Sizes 75-150 - 6001-8000 ft	171825 (replaces 120031)
	Pressure Switch, Tri Delta #PPS10138-2814	Sizes 175, 200 - 2001-6000 ft; Sizes 50, 175 - 6001-8000 ft	171826 (replaces 120322)
22	Indicator Light, Jemco #XL-9036-5JL, 24V (See page 4)	All Sizes	116045
23	Terminal Strip, 2 Pole - Doran Mfg. Co (See page 4)	All Sizes	96041
24	Power Cord 4'6", 115 volt, #068-32-41552	All Sizes	116046
	Power Cord 4'6", 208/230 volt, NEMA 6-15P	Sizes 50 - 150	120689
25	Transformer, 115V, 20 VA, Basler #BE141620-RAD		132204 (replaces 102709)
	Transformer, 208/230V, 40VA, Basler #BE21537004		103500
	Transformer, 115V, 35VA, Basler #BE141640-RAK		102708
26	Gas Valve - Natural, 1/2", Honeywell Model VR8204-M1000	Sizes 50 - 150	96307
	Gas Valve - Propane, 1/2", Honeywell Model VR8204-M1018	Sizes 50 - 150	96310
	Gas Valve - Natural, 1/2", Honeywell Model VR8304-M2824	Sizes 175-200	136193
27	Replacement Pilot Assy (for natural or propane, 0-6000 ft) - see page 7 for components and pilots for altitudes above 6000 ft	Size 50	110854
		Sizes 75 - 200	110853



Sizes	Gas	P/N
50-100	Natural	170609
125-150	Natural	96307
50-150	Propane	96310
175-200	Natural	136193

Code 27 - Spark Pilot 	Code	Size	Elevation	Gas	P/N	Component Description
	27A	50	0-6000	Natural	126060	Pilot Assy with orifice, pilot tubing, flame rod, less flame sensor lead and fitting
		75-200	0-6000	Natural	97534	Pilot Assy with orifice, pilot tubing, flame rod, less flame sensor lead and fitting, Johnson #J982HKW-9733-715
		50-150	0-6000	Propane		
		50-150	6001-8000	Propane		
		50-175	6001-8000	Natural	126060	Pilot Assy with orifice, pilot tubing, flame rod, less flame sensor lead and fitting
	27B	50-200	0-6000	Natural	103034	Orifice only, Johnson #9731-715 (brass)
		50-150	0-6000	Propane		
		50-150	6001-8000	Propane	134507	Orifice only, Johnson #7721D (red)
		50-175	6001-8000	Natural		
27C	All	0-8000	Natural and Propane	98698	Pilot Tubing, Johnson #B10499-995-11, 1/8" O.D. x 18" long	
27D				97572	Compression fitting, FTG75 (2 required when replacing pilot tubing)	
27E				98697	Flame Rod, Johnson #Y57AA-3	
27F				97575	Flame Sensor Lead, 21"	

Tubular System (Tubes, Reflectors, and Hardware) - Models TR/TR-H

Code	Description	P/N	Code	Description	P/N
34	Combustion Chamber Tube only	123196	43	Reflector End Cap with Hardware Bag (Same as Option CD27) - use only gap cover kits, Code 44	143563
35	Heat Exchanger Tube only - 10' straight	123198	44	Reflector Gap Cover Kits (Same as Options CD21-26 for 20'-70' tube lengths)	See list on page 8
36	Tail Pipe Tube	123200	45	"L" Heat Exchanger Tube with Reflector (Same as Option UC2) (component listing on page 8)	120713
37	Tube Connection Hardware Bag (see illustration below, for components)	116017	46	"U" Heat Exchanger Tube with Reflector (Same as Option UB3) (component listing on page 8)	120712
38A	Turbulator Section - 37-1/8"	116019	47	Package containing 5' Heat Exchanger Tube with Reflector (Same as Option UA1) (not illustrated)	125184
38B	Turbulator Section - 26"	120538	47A	Heat Exchanger Tube only - 5' straight	125185
39	Reflector Bracket	131787	47B	Reflector only for straight 5' tube	125186
40	Reflector Retainer	131786			
41	U-Bolt with brass nuts, 3/8-16 x 4-1/2	131785			
42	Reflector only for straight 10' tube	123202			

Code 34 - Combustion Chamber Tube



Code 35 - Heat Exchanger Tube



Code 36 - Tail Pipe Tube



Code 37 - Tube Connection Hardware

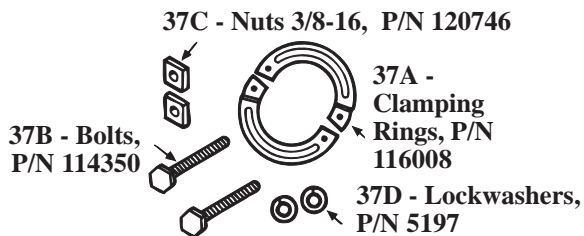

Codes 38A and B - Turbulator Section



Codes 39, 40, and 41 - Reflector Bracket, Retainer and Hardware

Complete Kit for 1 Tube, P/N 136128
 Complete Kit for 2 Tubes, P/N 136129
 Complete Kit for 3 Tubes, P/N 136130

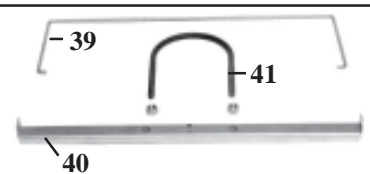

Code 42 - Reflector



Code 43 - Reflector End Cover

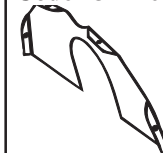

Reflector end cover must be used with reflector gap covers (Code 44). End cover cannot be installed on a tube without a gap cover.

Tubular System - Models TR/TR-H (cont'd)

Code 44 - Reflector Gap Covers

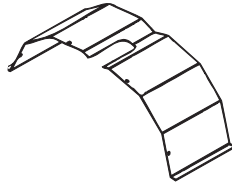

No. of Tubes	Same as Option	P/N
2	CD21	143500
3	CD22	143501
4	CD23	143502
5	CD24	143503
6	CD25	143504
7	CD26	143505

Code 45 - "L" Heat Exchanger Tube Package with Reflector (Same as Option UC2)

Components -- "L" Tube only, P/N 120535; "L" Tube Reflector Right Half, P/N 144415; "L" Tube Reflector Left Half, P/N 144416; "L" Tube Reflector Side, P/N 144417; Reflector Hardware Bag, P/N 143474



Code 46 - "U" Heat Exchanger Tube Package (Same as Option UB3)

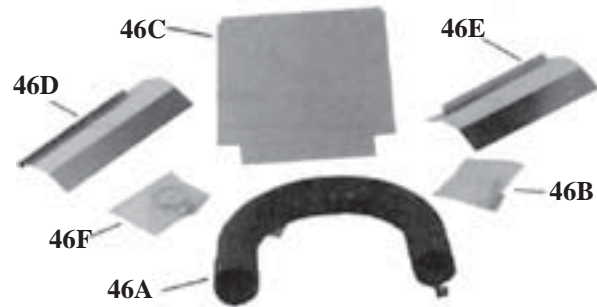

Code	Qty	P/N	Component Description
46A	1	120534	"U" Heat Exchanger Tube
46B	1	116017	Tube Connecting Hardware Bag
46C	1	120993	Reflector Top
46D	1	120994	Reflector Right Side
46E	1	120995	Reflector Left Side
46F	1	120719	Reflector Hardware Bag including: 14 - P/N 113275, Screws #10-32 x 1/2" lg; 2 - P/N 113807, Washers; 14 - P/N 26490, Nuts Kep #10-32

Tubular System Cartons and Packaging Scheme

Code	Qty	Code	P/N	Description	Qty	Code	P/N	Description	Qty	Code	P/N	Description
48	Tubular System Package , P/N 120294, includes											
	1	34	123196	Combustion Chamber Tube	1	36	123200	Tail Pipe Tube	4	39	131787	Reflector Bracket
	4	40	131786	Reflector Retainer	4	41	131785	U-Bolt w/brass nuts	2	42	123202	Reflectors
	3	38A	116019	Turbulator	1	38B	120538	Turbulator	1	37	116017	Tube Connection Hardware Bag
49	Tubular System Package , P/N 120295, includes											
	1	34	123196	Combustion Chamber Tube	1	35	123198	Heat Exchanger Tube	1	36	123200	Tail Pipe Tube
	6	39	131787	Reflector Bracket	6	40	131786	Reflector Retainer	6	41	131785	U-Bolt w/brass nuts
	3	42	123202	Reflectors	3	38A	116019	Turbulator	2	37	116017	Tube Connection Hardware Bag
50	Tubular System Package , P/N 120296, includes											
	2	35	123198	Heat Exchanger Tube	4	39	131787	Reflector Bracket	4	40	131786	Reflector Retainer
	4	41	131785	U-Bolt with brass nuts	2	42	123202	Reflectors	2	37	116017	Tube Connection Hardware Bag
	2	38A	116019	Turbulator								

Tube Packages above Required by Length of System

Length of Tubular System	20ft	30ft	40ft	50ft	60ft	70ft
Required Pkgs by Codes above (quantity in parenthesis)	(1) Code 48	(1) Code 49	(1) Code 48 (1) Code 50	(1) Code 49 (1) Code 50	(1) Code 48 (2) Code 50	(1) Code 49 (2) Code 50

High Altitude and Gas Conversion Kits - Model TR

Code 51 - High Altitude Conversion Kits for Model TR

Type of Gas	Natural Gas							Propane Gas				
BTUH Size	50	75	100	125*	150*	175	200	50	75	100	125*	150*
Elevation	2001-4000 feet (611-1219 meters)											
Pkg P/N	126440	120880	120882	132664	132667	132670	132673	126441	120881	120883	132676	132679
Elevation	4001-6000 feet (1220-1829 meters)											
Pkg P/N	126442	120884	120886	132682	132685	132688	132691	126443	120885	120887	132694	132697
Elevation	6001-8000 feet (1830-2438 meters)											
Pkg P/N	126444	120888	120890	132700	132703	132706	--	126445	120889	120891	132712	132715

* Sizes 125 and 150 - Do not install a High Altitude Conversion Kit in a Size 125 or 150 heater that is factory built for operation at sea level (0-2000 ft elevation). These kits for Size 125 and 150 heaters are designed only to change the elevation range of a heater that is factory-built for operation above 2000 ft.

Code 52 - Gas Conversion Kits for Model TR (sea level only)

Sizes	Natural to Propane	Propane to Natural
TR 75 and 100	193859	193861
TR 125 and 150	193860	193862

IMPORTANT: When selecting a gas conversion kit, check

- Rating plate information
- For size conversion label (see page 2)
- For altitude conversion label (gas conversion kits are not available for high altitude; consult the factory)

NOTES: Gas conversion kits are not available for Size 50. Sizes 175 and 200 are available for use with natural gas only.

Replacement Parts - Model TRP

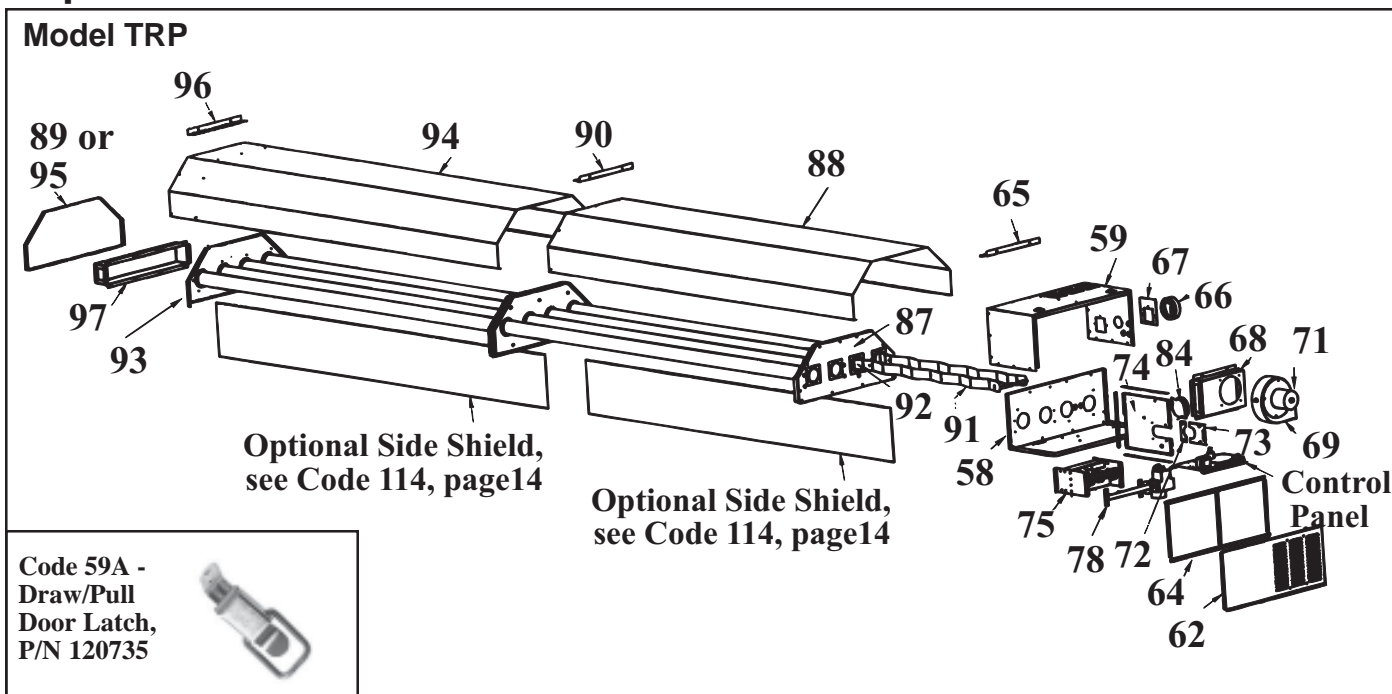

Code	Description	30	50	60	100	
57	Complete Burner Box Assy - standard unit (natural gas, power vent, indoor)	173868	173869	173870	173871	
58	Burner Box Panel Assy with viewport	(1)173847	(1)173847	(1)173849	(1)173849	
59	Burner Box Top & Sides Assy	(1)173872	(1)173874	(1)173873	(1)173875	
	Burner Box Top & Sides Assy - Option AV5 (includes air inlet collar)	(1)174252	(1)174253	(1)174254	(1)174255	
	Burner Box Top & Sides Assy for Outdoor unit - Option AYW2	(1)175851	(1)175852	(1)175853	(1)175854	
59A	Draw/Pull Door Latch	(2)120735	(2)120735	(2)120735	(2)120735	
60	Top Rainhood and Gasket Assy - Outdoor unit, Option AYW2 (see pg 10)	(1)175859	(1)175859	(1)175860	(1)175860	
61	Self-adhesive tube gasket, 1/8" (not illustrated)	(2)173705	(2)173705	(4)173705	(4)173705	
62	Burner Box Door Assembly	(1)173636	(1)173636	(1)173638	(1)173638	
63	Neoprene Gaskets for Door Opening	16" x 12" x 24"	--	--	(2)173689	(2)173689
		16" x 12" x 18"	(2)173690	(2)173690	--	--
		3/16" x 12" x 9"	(2)173691	(2)173691	(2)173691	(2)173691
64	Door Rainhood and Gasket Assy - Outdoor unit, Option AYW2 (see pg 10)	(1)175430	(1)175430	(1)175430	(1)175430	
65	Burner Box Hanger	(1)173856	(1)173856	(1)173858	(1)173858	
66	Flue Collar, 4"	(1)147220	(1)147220	(1)147220	(1)173891	
67	Flue Collar Gasket	(1)174265	(1)174265	(1)174265	(1)174264	
68	Flue Wrapper Assy	(1)173641	(1)173666	(1)173665	(1)173664	
68A	Top/Btm Flue Wrapper Gasket	(not illustrated)	(2)173669	(2)173668	(2)173668	
68B	Side Flue Wrapper Gasket	(not illustrated)	(2)173667	(2)173876	(2)173876	
69	Venter Housing Assembly with gasket	(1)173713	(1)173851	(1)173854	(1)173855	
69A	Static Pressure Tap	(1)116043	(1)116043	(1)116043	(1)116043	

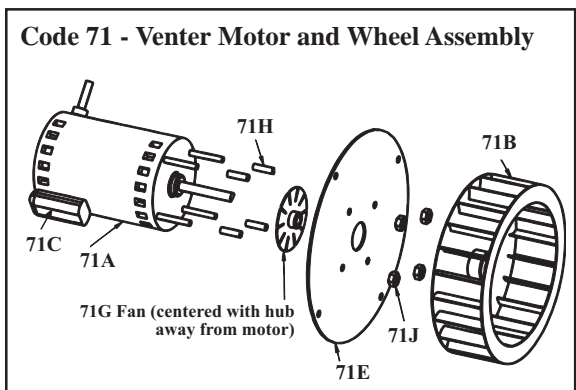

Code	Description	30	50	60	100
71	Venter Mtr & Wheel Assy	(1)174017	(1)174017	(1)174017	(1)121052
71A	Venter Motor	(1)148055	(1)148055	(1)148055	(1)148053
71B	Venter Wheel	(1)135979	(1)135979	(1)135979	(1)120545
71C	Venter Motor Capacitor	--	--	--	(1)163894
71D	Capacitor Boot	--	--	--	(1)103182
71E	Motor Mounting Plate	(1)174275	(1)174275	(1)174275	(1)120997
71F	Mtr Mntng Plate Gasket	(1)155651	(1)155651	(1)155651	--
71G	Fan Blade	(1)68005	(1)68005	(1)68005	(1)68005
71H	Spacers	(4)97721	(4)97721	(4)97721	(4)97722
			#8 x 3/4" long		#8x15/16" lg
71J	Kep Nut #8-32	(4)31522	(4)31522	(4)31522	(5)31522

Replacement Parts - Model TRP (cont'd)

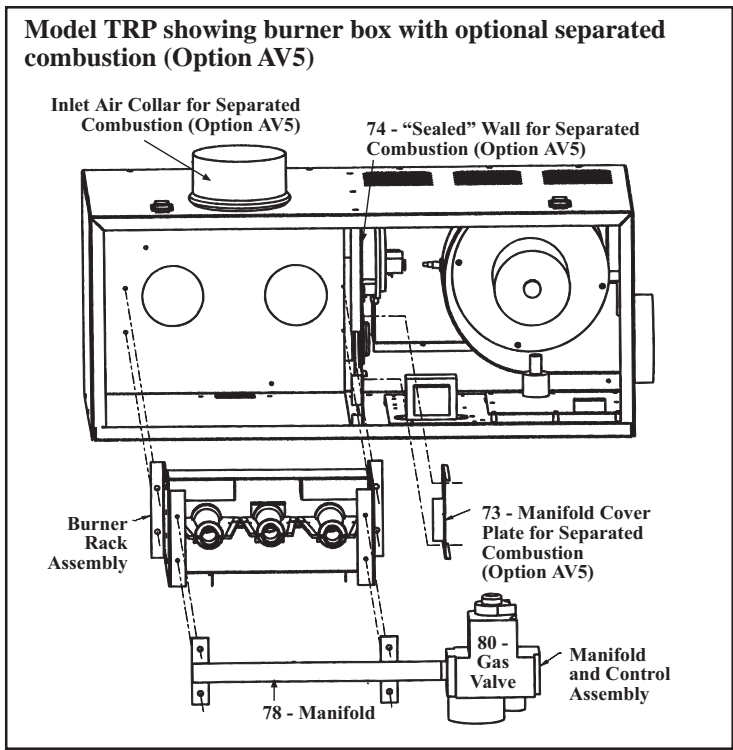
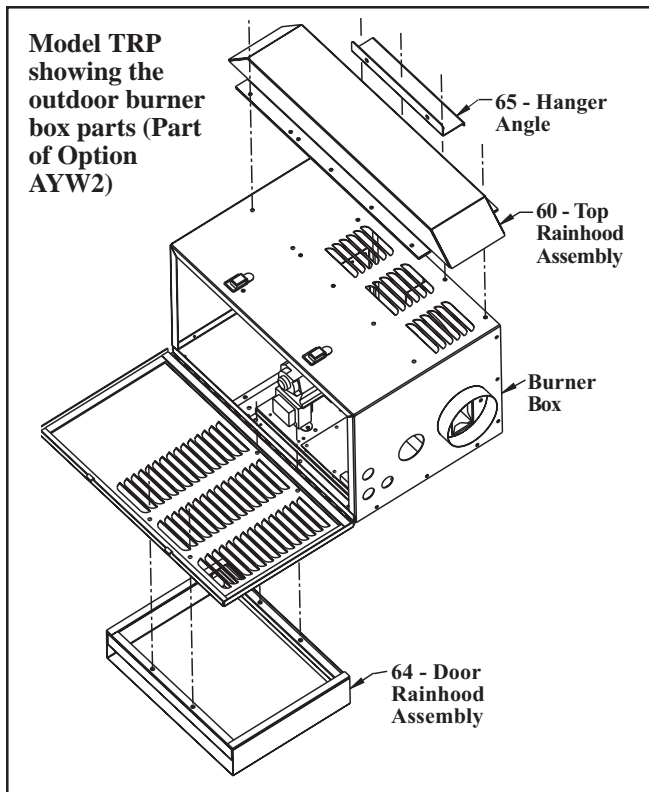

Code 76 - Spark Electrode Assy with 24" Lead, P/N 173878

Code 77 - Flame Sensor, P/N 147165

Code 80 - Gas Valve

Natural Gas Valve for TRP 30, 50, 60, P/N 172552, Honeywell VR8105M2187 (illustrated)
Natural Gas Valve for TRP 100, P/N 147830, Honeywell VR8205M1130
Propane Gas Valve for TRP 30, 50, 60, P/N 172553, Honeywell VR8105RM2825
Propane Gas Valve for TRP 100, P/N 147560, Honeywell VR8205M1148

Code 82 - Transformer, 30 VA, 120V/24V, P/N 147356

Code 83 - Integrated Control Module, P/N 174260

Code 84 - Pressure Switch

Pressure Switch for TRP 30, 0 to 4000 ft elevation, P/N 174020
Pressure Switch for TRP 50, 60, 100, 0 to 4000 ft elevation, P/N 174435
Pressure Switch for TRP 30, over 4000 ft elevation, P/N 174420
Pressure Switch for TRP 50, 60, 100, over 4000 ft elevation, P/N 174436

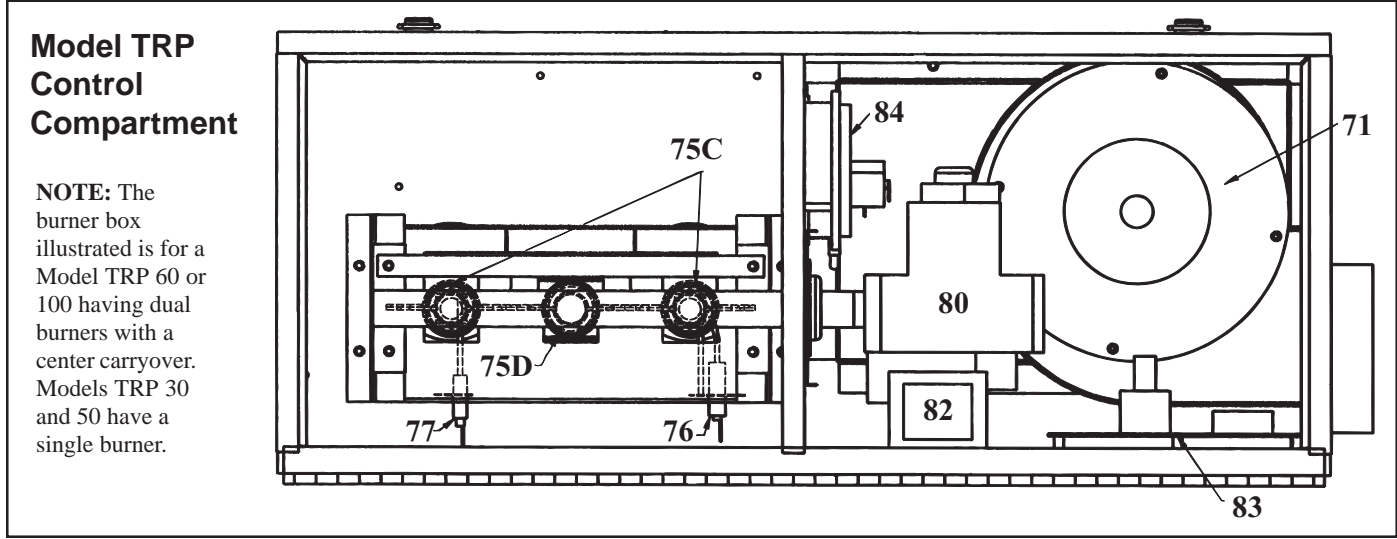

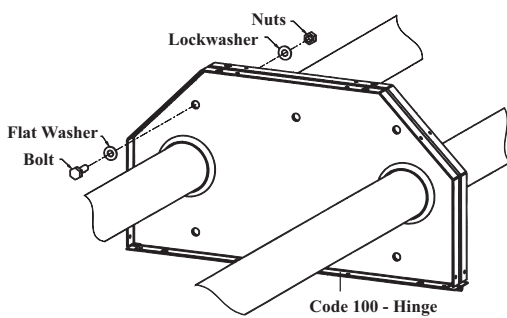
Code	Description	30	50	60	100	
72	Seal Plate - Option AV5 (separated combustion)	(1)173672	(1)173672	(1)173672	(1)173672	
73	Manifold Cover Plate with Gasket - Option AV5 (separated combustion)	(1)174025	(1)174026	(1)174025	(1)174026	
74	Wall - Option AV5 (separated-combustion) only	(1)173670	(1)173671	(1)173670	(1)173671	
75	Burner Rack Assy	175290	175291	175292	175293	
75A	Burner Rack Mounting Bracket	(2)174046	(2)174045	(2)174046	(2)174045	
75B	Burner Support	(1)174047	(1)174047	(1)174048	(1)174048	
75C	Burner, Beckett #10920X	(1)173618	(1)173618	(2)173618	(2)173618	
75D	Carry over Burner Assy	--	--	(1)173639	(1)173639	
75E	Ignitor/Sensor Bracket (not illustrated)	(1)173845	(1)173845	(1)174050	(1)174050	
76	Spark Electrode Assy with 24" lead	(1)173878	(1)173878	(1)173878	(1)173878	
77	Flame Sensor	(1)147165	(1)147165	(1)147165	(1)147165	
78	Manifold	(1)173613	(1)173613	(1)173614	(1)173614	
79	Burner Orifice	See table on page 12.				
80	Gas Valve, Honeywell, 1/2" x 1/2", 3.5" w.c., 24V, natural gas (For propane to natural gas conversion kits, see Code 108, page 12.)	(1)172552	(1)172552	(1)172552	(1)147830	
	Gas Valve, Honeywell, 1/2" x 1/2", 24V, propane gas (For natural to propane gas conversion kits, see Code 107, page 12.)	(1)172553	(1)172553	(1)172553	(1)147560	
81	Orifice for Carryover Burner, natural gas, J/C #7715 (not illustrated)	--	--	(1)93973	(1)93973	
	Orifice for Carryover Burner, propane gas, J/C #9733 (not illustrated)	--	--	(1)98695	(1)98695	
82	Transformer, 30VA, 120V/24V	(1)147356	(1)147356	(1)147356	(1)147356	
83	Integrated Control Module	(1)174260	(1)174260	(1)174260	(1)174260	
84	Pressure Switch, 0 to 4000 ft elevation	(1)174020	(1)174435	(1)174435	(1)174435	
	Pressure Switch, over 4000 ft elevation	(1)174420	(1)174436	(1)174436	(1)174436	
85	Silicone Sensor Tubing 3/16" x 13" - all	(1)123727	(1)123727	(1)123727	(1)123727	
	Silicone Sensor Tubing 3/16" x 4" - Option AV5, separated combustion	(1)113774	(1)113774	(1)113774	(1)113774	
	Silicone Sensor Tubing 3/16" x 5-1/4" - Option AV5, separated combustion	(1)123728	(1)123728	(1)123728	(1)123728	
86	Power Supply Cord, 3.5 ft, Indoor (not illustrated)	(1)116046	(1)116046	(1)116046	(1)116046	
	Power Supply Cord, 3.5 ft, Outdoor (Option AYW2) (not illustrated)	(1)173692	(1)173692	(1)173692	(1)173692	
NOTE: Refer to illustration on page 9 to identify Codes 87-99						
87	Heat Exchanger & Reflector Assy (includes turning box; for replacement turning box only, see Code 97) - 1st Section (next to burner box) or only section Sizes 30 & 60	(1)173866	(1)173867	(1)173861	(1)173678	
88	Reflector	(1)173686	(1)173687	(1)173699	(1)173700	
89	Reflector End Cap	(1)173701	--	(1)173702	--	
90	Mid Hanger	(1)173857	(1)173857	(1)173859	(1)173859	
91	Turbulator Type 1	(1)173881	(1)173881	(2)173881	(2)173881	
92	Turbulator Type 2	(1)173882	(1)173882	(2)173882	(2)173882	
93	Heat Exchanger & Reflector Assy (includes turning box; for replacement turning box only, see Code 97) - 2nd Section (next to turning end) on Sizes 50 and 100	--	(1)174019	--	(1)173896	
94	Reflector	--	(1)173686	--	(1)173699	
95	Reflector End Cap	--	(1)173701	--	(1)173702	
96	Mid Hanger	--	(1)173857	--	(1)173859	
97	Replacement Turning Box Assy	(1)173649	(1)173649	(1)173650	(1)173650	
98	Top/Btm Turning Box Gskt (not illustrated)	(2)173853	(2)173853	(2)173659	(2)173659	
99	Side Turning Box Gskt (not illustrated)	(2)173658	(2)173658	(2)173658	(2)173658	
100	Hinge (connects the center plates of the two heat exchanger sections on Sizes 50 and 100 - See Code 101 for field-installed hardware)	--	(1)173615 18" long	--	(1)173616 24" long	
101		Self-adhesive Tube Gasket, 1/8" thick	--	(2)173705	--	(4)173705
		1/4" Kep Nut	--	(6)7328	--	(6)7328
		1/4" x 3/4" long Hex Head Bolt	--	(6)16246	--	(6)16246
		1/4" Flat Washer	--	(6)1320	--	(6)1320
		1/4" Lockwasher	--	(6)1319	--	(6)1319
102	1/0 Double Loop Chain (Sizes 30 & 60 - 25 ft chain; Sizes 50 & 100 - 50 ft chain)	(1)173693	(1)120703	(1)173693	(1)120703	
103	"S" Hooks 1/4"	(8)116034	(12)116034	(8)116034	(12)116034	



Replacement Parts - Model TRP (cont'd)

Code 79 - Burner Orifices



Model TRP			30	50	60	100	
BURNER ORIFICES			Qty	1	1	2	2
Natural Gas, 0-2000 ft			P/N	11835	173846	11835	173846
			Size	#37	3.4 mm	#37	3.4 mm
Propane Gas, 0-2000 ft			P/N	97631	16590	97631	16590
			Size	1.6mm	#46	1.6mm	#46
For installation in Canada	Natural Gas	2001-4500 ft	P/N	45871	173846	45871	173846
			Size	#39	3.4mm	#39	3.4mm
	Propane Gas	ft	P/N	9789	84853	9789	84853
			Size	#53	#47	#53	#47
For installation in U.S.A.	Natural Gas	2001-3000 ft	P/N	45870	173846	45870	173846
			Size	#38	3.4mm	#38	3.4mm
	Propane Gas	ft	P/N	97631	84853	97631	84853
			Size	1.6mm	#47	1.6mm	#47
	Natural Gas	3001-4000 ft	P/N	45871	173846	45871	173846
			Size	#39	3.4mm	#39	3.4mm
	Propane Gas	ft	P/N	9789	84853	9789	84853
			Size	#53	#47	#53	#47
	Natural Gas	4001-5000 ft	P/N	45871	173846	45871	173846
			Size	#39	3.4mm	#39	3.4mm
	Propane Gas	ft	P/N	9789	84853	9789	84853
			Size	#53	#47	#53	#47
Natural Gas	5001-6000 ft	P/N	87391	26112	87391	26112	
		Size	#40	#30	#40	#30	
Propane Gas	ft	P/N	9789	40414	9789	40414	
		Size	#53	#48	#53	#48	
Natural Gas	6001-7000 ft	P/N	11792	26112	11792	26112	
		Size	#41	#30	#41	#30	
Propane Gas	ft	P/N	9789	40414	9789	40414	
		Size	#53	#48	#53	#48	
Natural Gas	7001-8000 ft	P/N	84437	26113	84437	26113	
		Size	#42	#31	#42	#31	
Propane Gas	ft	P/N	9789	39651	9789	39651	
		Size	#53	#49	#53	#49	
Natural Gas	8001-9000 ft	P/N	84437	26113	84437	26113	
		Size	#42	#31	#42	#31	
Propane Gas	ft	P/N	11834	39651	11834	39651	
		Size	#54	#49	#54	#49	

NOTE: Above 4000 ft requires pressure switch change. See Code 84 on page 11.

Components of Code 104, Option CC6, Horizontal Vent Terminal/Combustion Air Packages for Optional Separated Combustion:

Qty	Description	30, 50, 60	100
	Complete Horizontal Vent Kit (Same as Option CC6)	157157	157158
1	Concentric Box Assembly 	155118	155392
1	Screened Exhaust Assembly 	155096	155096
1	Inlet Guard 	151755	151755
4	#10-16x1/2" lg Screws (to attach the inlet guard)	37661	37661
1	4" I.D. Rubber Seal	164492	164492
1	Tube of High Temperature Silicone Rubber Sealant	53335	53335

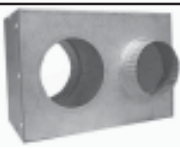
Components of Code 105, Option CC2, Vertical Vent Terminal/Combustion Air Packages for Optional Separated Combustion:

Qty	Description	30, 50, 60	100
	Complete Vertical Vent Kit (Same as Option CC2)	157155	157156
1	Concentric Box Assembly 	155118	155392
1	Exhaust Terminal 	155631	155631
1	Combustion Air Inlet 	155635	155635
1	4" I.D. Rubber Seal	164492	164492
1	Tube of High Temperature Silicone Rubber Sealant	53335	53335

Kits and Accessories - Model TRP

Code	Kits and Components		30	50	60	100
104	Horizontal Combustion Air Inlet /Vent Concentric Adapter and Terminal Kit (same as Opt CC6)	Option CC2 or CC6 is required with Opt AV5, separated combustion. See components above.	157157	157157	157157	157158
105	Vertical Combustion Air Inlet /Vent Concentric Adapter and Terminal Kit (same as Opt CC2)		157155	157155	157155	157156
106	Vent Cap, 4", Same as Option CC1		110051	110051	110051	110051
107	Gas Conversion Kits - Natural to Propane	for Model TRP heaters with standard power vent	175610	175611	175612	175613
		for heaters with optional separated combustion (Opt AV5)	175610	175611	175612	175624
108	Gas Conversion Kits - Propane to Natural for all Model TRP		175617	175618	175617	175618

Code 106 - 4" Vent Cap (Same as Option CC1; required on outdoor unit)



Options and Accessories - Apply to Models TR/TRH and/or Model TRP as indicated

Code 109 - Single-Stage Thermostat, W/R #1C30-341 (Same as Option CL1), P/N 91919 - Applies to Models TR, TR/H, and TRP



24 Volt
40-80° F Range
Snap Action Contacts
30 V.A.C. Maximum
.15 to 1.0 Amps
Adjustable Anticipator
Vertical Mounting with Wall Mounting Plate
Dial "off" Switch

Code 110 - Thermostat Cover, W/R 29-0143 (Same as Option CM1), P/N 91926- Applies to Models TR, TR/H, and TRP

Clear Plastic
Locking Cover



Code	Description (see illustrations below and on page 14)	Applies to Model	P/N
111	Complete Combustion Air Inlet Kit (Same as Option DE2)	TR and TR/H	120724
112	Dual Vent Kit (Same as Option CC5) - See illustration below for components	TR, TR/H, and TRP	120736
113	Turnbuckle, Forged Carbon Steel, #10704, with Lock Nut (part of Options CK 12-18)	TR, TR/H, and TRP	120704
114	Side Shield Package (hangs along rear of tubular system)	TR, TR/H, and TRP	See List
115	Multiple Heater Control Pkg (for 115V master and one slave, same as Option CL31)	TR and TR/H	102248
116	Multiple Heater Control Pkg (for 208/230V master & all slave units, same as Option CL32)	TR and TR/H	102249
117	Thermostat Bracket Package for Heater Mounting (Same as Option CM3)	TR and TR/H	98524
118	Gas Connector, 1/2" Flexible, 24" long Stainless (Same as Option CE3)	TR, TR/H, and TRP	120715
	Gas Connector, 3/4" Flexible, 24" long Stainless (Same as Option CE4)	TR, TR/H, and TRP	120874
119	Hanger Chain Kit (Same as Option CK11)	TR and TR/H	120698
	<u>Components:</u> Hanging Chain, 50 ft, 200 lb load, P/N 120703; "S" Hook, 1/4", Campbell #610-8024, P/N 116034	(For chain and hooks for TRP, see Codes 101 and 102, page 11.)	

Code 111 - Combustion Air Inlet Kit (Same as Option DE2 for TR and TR/H)



Code	Qty	P/N	Component Description
111A	1	120729	Expandable Combustion Air Inlet Pipe, 4" dia.
111B	2	120716	Clamp, Worm Drive, 1/2" Stainless Steel
111C	1	120726	Inlet Cap, 4"

Code 112 - Dual Vent Kit (Same as Option CC5 for TR, TR/H, and TRP)

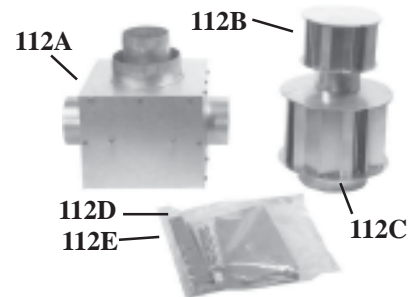

Code	Qty	P/N	Component Description
112A	1	120291	Dual Vent Adapter Box
112B	1	110051	4" Vent Cap
112C	1	120869	6" Vent Cap
112D	1	53335	Tube of Silicone Rubber
112E	2	120108	Support Angles

Code 113, Turnbuckle and Turnbuckle Lock Nut for Models TR, TR-H, and TRP

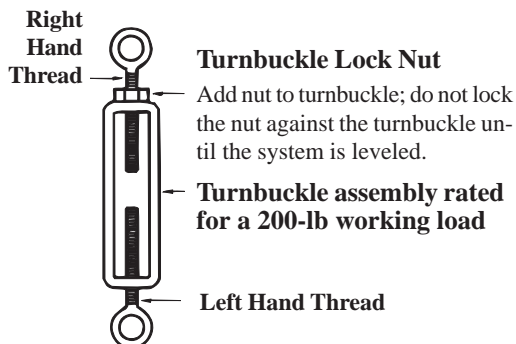

Each package (kit) includes equal quantities of:
Eye-to-Eye Turnbuckle of forged carbon steel, P/N 120704, and 5/16-18 Nut (Kep), P/N 6554

Model	Straight Tube Length (feet)	System Configuration					
		Straight or "L"			"U"		
		Option No.	Package P/N	Qty per pkg	Option No.	Package P/N	Qty per pkg
TR/TR-H	20	CK12	120699	4	CK13	121045	5
	30	CK13	121045	5	CK14	120700	6
	40	CK14	120700	6	CK15	121046	7
	50	CK15	121046	7	CK16	120701	8
	60	CK16	120701	8	CK17	121047	9
	70	CK17	121047	9	CK18	132517	10
TRP 30 & 60	N/A	CK12	120699	4			
TRP 50 & 100	N/A	CK14	120700	6			

Options and Accessories - Apply to Models TR/TRH and/or Model TRP as indicated (cont'd)

Code 114 - Optional Side Shield Kits

Side Shield Kits for Models TR and TR/H

Side Shield Kits for Model TRP

Side Shield Option Kits for Model TRP heaters:

Option	CD30		CD31	
Applies to	TRP 30 & 60		TRP 50 & 100	
Option Pkg P/N	175288		175289	
	Qty	P/N	Qty	P/N
Side Shield	2	173888	2	173888
			2	173892
U-Type Nut	4	1849	8	1849
1/4" Flat Washer	4	1320	8	1320
Sheetmetal Screw #10 x 1/2"	4	11813	8	11813

	Length of Shielded Tubes - Models TR and TR/H															
	5'		10'		20'		30'		40'		50'		60'		70'	
Option Designation	CD19		CD13		CD14		CD15		CD16		CD17		CD18		CD20	
Option Package P/N	125340		120132		120705		120706		120707		120708		120709		132059	
	Qty	P/N	Qty	P/N	Qty	P/N	Qty	P/N	Qty	P/N	Qty	P/N	Qty	P/N	Qty	P/N
Side Shield Modular Section	1	116020	2	116020	4	116020	6	116020	8	116020	10	116020	12	116020	14	116020
Reflector Bracket	0	—	2	131787	4	131787	6	131787	8	131787	10	131787	12	131787	14	131787
U-Bolt with two Brass Nuts	0	—	2	131785	4	131785	6	131785	8	131785	10	131785	12	131785	14	131785
Reflector Retainer	0	—	2	131786	4	131786	6	131786	8	131786	10	131786	12	131786	14	131786
#10-32 x 1/2" long Screw	1	113275	1	113275	2	113275	3	113275	4	113275	5	113275	6	113275	7	113275

Codes 115 and 116 - Multiple Heater Control Packages (Same as Options CL31 and CL32 for Models TR and TR/H)

	CL31	CL32	P/N	Component
A	1	--	102708	Transformer 35VA, Basler #BE141640-RAK
B	2	--	103152	Sheet Metal Screws, #6 x 1-3/4" lg (to hold transformer)
C	2	1	102243	RBM Relay Assembly consisting of one P/N 98118 RBM Relay (WR #134-20102-101) wired & mounted on a specially designed bracket
D	2	1	16228	Cable Clamp 3/16"
E	2	1	131127	Wiring Diagram Label
G	4	2	121033	Screws, #8 x 1" lg
F	4	2	98872	Spacers

NOTE: Pkg P/N 102248 also includes two Tinnerman clips which are not used on Model TR. Pkg covers multiple product lines.

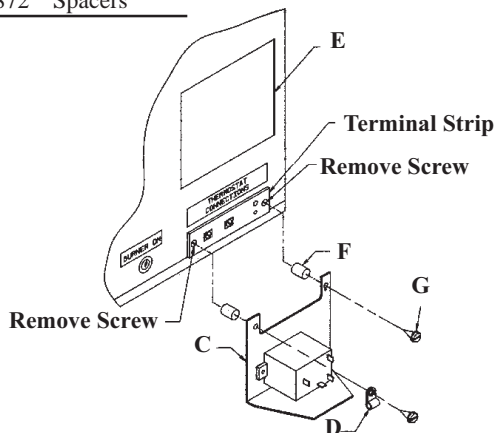

Code 117 - Thermostat Bracket Package (Same as Option CM3)

Qty	P/N	Component
A	1	98353 Bracket
B	2	3618 Chase Nipple, 1/2", T&B #842
C	1	7447 Coupling Conduit Connector, 1/2"
D	1	17782 Outlet Box, 2" x 4"
E	2	98872 Spacer, 1/4"x7/16"lg, Spirol #SP100
F	2	121033 Screws, #8 x 1" long

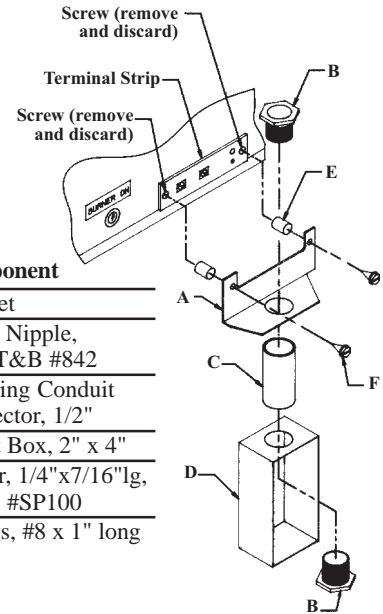

Code 119 - Flexible Gas Connector (Options CE3 and CE4 for TR, TR/H and TRP)

1/2", P/N 120715; 3/4", P/N 120874



High-Intensity Infrared Models RIH/RIHV

Controls - All RIH/RIHV High-Intensity Infrared Models

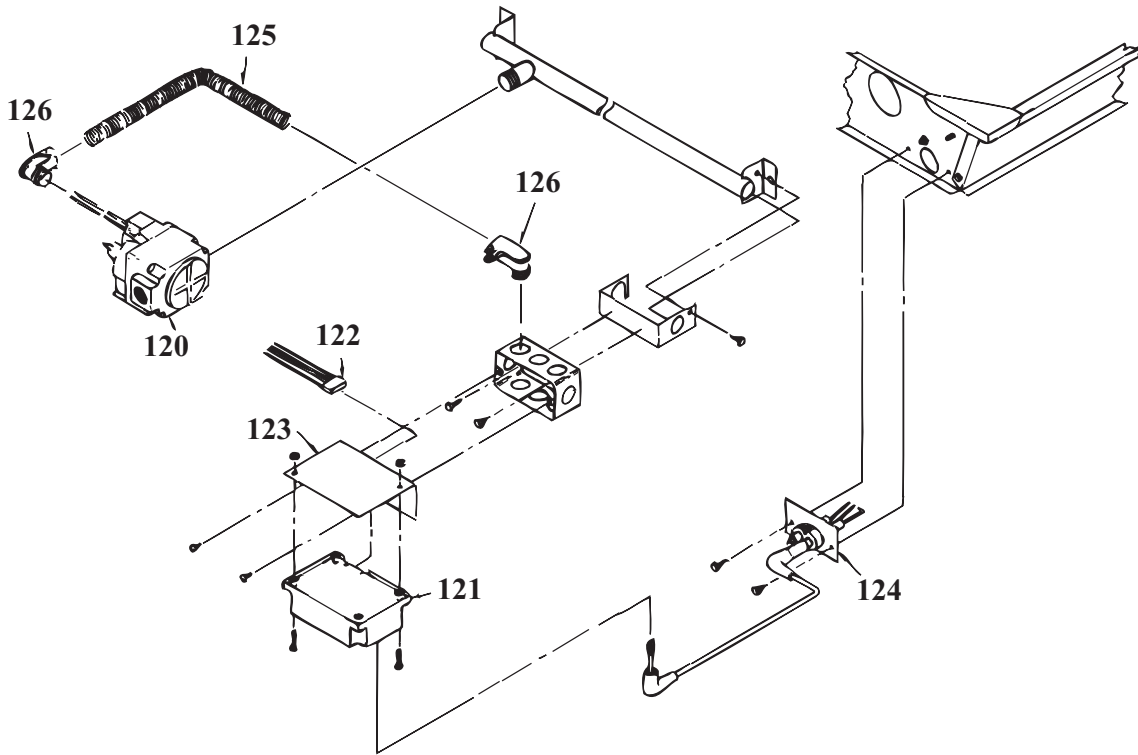

Code	P/N	Description
120	112044	Main Valve (115V) - 1/2" NPT, 002-42-01536C01A284 (natural and propane)
121	96010	Ignition Detection Control, Mark 10X-117, #132075-2, Pkg R9
122	96011	Wire Harness, #132084, Pkg R10
123	112045	Ignition Detection Control Mounting Bracket, #000K-1-016
124	112046	Ignitor, #0002-42-110
125		Conduit, 3/8" Greenfield with Anti-Short Bushings
	112047	for RIHN30, RIHN60, RIHL50 , #3802-95-300-01
	112048	for RIHVN 100, RIHVL90 , #3802-95-300-02
	112049	for RIHVN 150, RIHVL 120 , #3802-95-300-03
	112050	for RIHVN 160 , #3802-95-300-04
126	112051	Angle Connector for 3/8" Greenfield, #3802-95-302

Miscellaneous Replacement Parts and Accessories - Models RIH/RIHV

Description	Same as Option	P/N
Chain - 50', 200 lb with 14 "S" Hooks	UE-1	95995
Chain Hanging Kit - see illustration and instructions on the right	UE-2	110253
Stainless Flex Gas Connector, 24", 7/8" O.D. with 1/2 gas cock with pressure tap	UF-2	96000
Single-Stage Thermostat - see illustration below	CL34	110252



Single-Stage Thermostat, P/N 110252

115/24 Volt
50-90°F Range
Snap Action Switch
Vertical Mounting
Mfg #132026-1

Chain Hanging Kit, P/N 110253

Instructions:

- 1) Hang full length chain at desired height and attach heater (C) with S-hooks
- 2) Attach one end of the 1' length chain with S-hooks to front of heater (D).
- 3) Place other end of chain with S-hook in hook (B) on the full length chain.
- 4) Change degree of angle by moving "S" hook at point B.
- 5) Check to be sure unit is level. Crimp all "S" hooks closed.

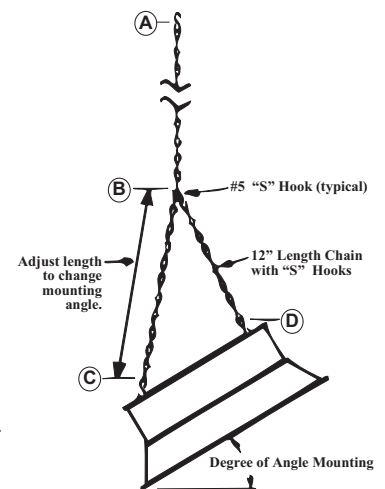

Miscellaneous Replacement Parts and Accessories (cont'd) - Models RIH/RIHV

High-Intensity Infrared Models	RIHN 30, RIHN 60, RIHL 50			RIHVN 100, RIHVL 90			RIHVN 150, RIHVL 120			RIHVN 160		
	Code	P/N	Qty	Code	P/N	Qty	Code	P/N	Qty	Code	P/N	Qty
Burner Assy (Combustion Chamber with Tile)	129	112052	1	137	112052	2	145	112052	3	152	112052	4
Gas Manifold	130	112053	1	138	112054	1	146	112055	1	153	112056	1
Main Gas Orifice - See table below	131			139			147			154		
Standard Reflector Assy	132	112057	1	140	112058	1	148	112059	1	155	112060	1
Wire Grid (Same as Option DN-2)	133	110246	1	141	110247	1	149	110248	1	156	110249	1
Protective Screen for unit w/ Std Reflector (Same as Opt DN-3)	134	115381	1	142	115382	1	150	115383	1	157	115384	1
Parabolic Reflector (Same as Opt DM-2)	135	110242	1	143	110243	1	151	110244	1	158	110245	1
Heat Shield (Same as Option DO-2)	136	110250	1	144	110251	1	--	--	-	--	--	-

Main Gas Orifice Chart (Codes 131, 139, 147, and 154)

	RIHN 30	RIHN 60	RIHL 50	RIHVN 100	RIHVL 90	RIHVN 150	RIHVL 120	RIHVN 160
Qty	1	1	1	2	2	3	3	4
P/N	113191	143574	112103	112102	112104	112102	112105	112709
Size	#43	#30	#46	#32	5/64"	#32	#49	#36

Models RIHVN 150, RIHVL 120

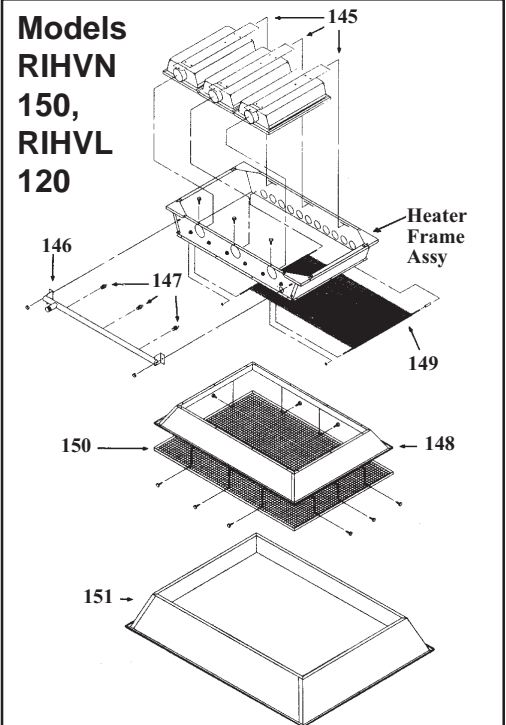

Model RIHVN 160

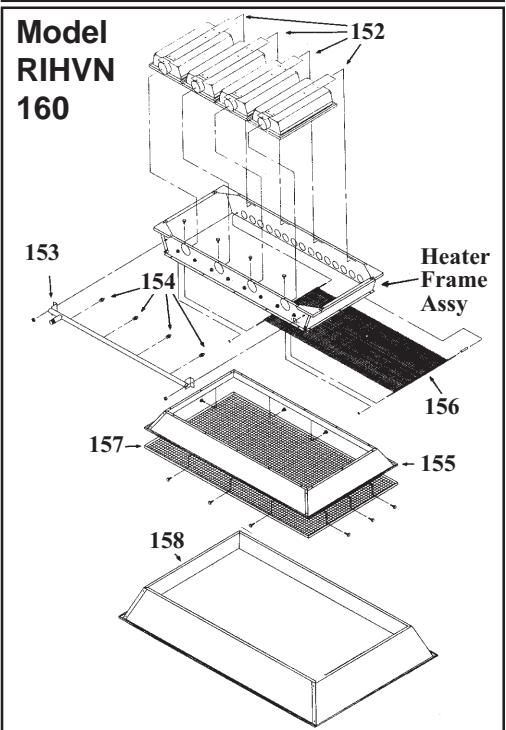

Models RIHN 30, RIHN 60, RIHL 50

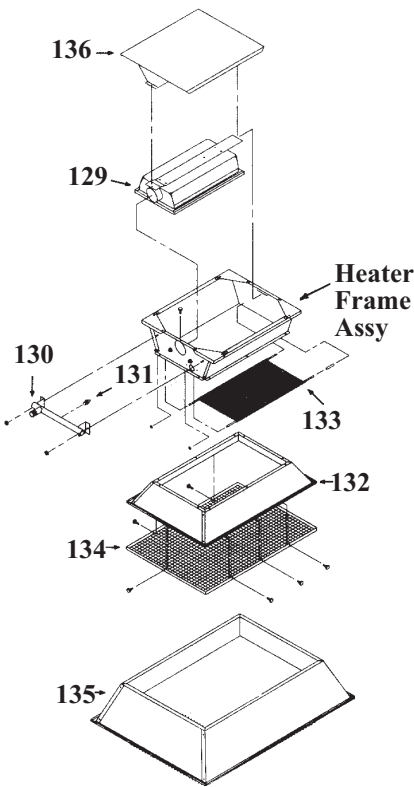

Models RIHVN 100, RIHVL 90

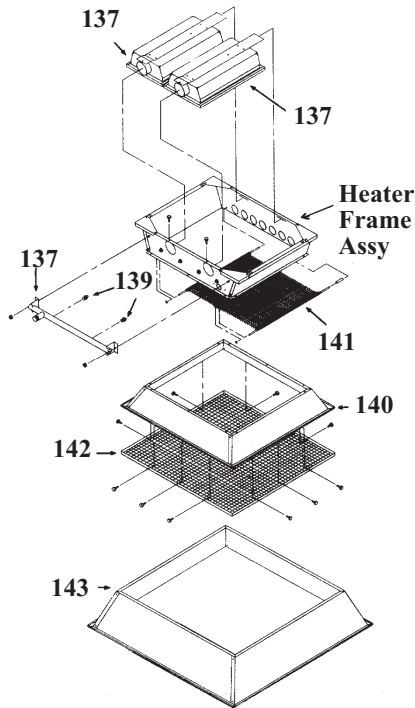

Thomas & Betts

©2000 Thomas & Betts Corporation, All rights reserved. Printed in U.S.A.
 MANUFACTURER OF GAS, OIL, ELECTRIC HEATING AND VENTILATING SYSTEMS
 Trademark Note: Reznor® is registered in the United States and other countries.