

SUBMITTAL DATA SHEET

Two Piece Brass Saddle - 3806

C900 PVC x FNPT



MODEL	SIZE	A	B	C	D	E	F
3806	4 X 3/4	3/4	1.23	2.38	1.50	HEX	4.800
3806	4 X 1	1	1.32	2.56	1.72	HEX	4.800
3806	4 X 1 1/2	1 1/2	1.50	3.46	2.34	OCT	4.800
3806	4 X 2	2	1.50	3.72	2.82	OCT	4.800
3806	6 X 3/4	3/4	1.28	2.26	1.50	HEX	6.900
3806	6 X 1	1	1.24	2.56	1.72	HEX	6.900
3806	6 X 1 1/2	1 1/2	1.63	3.46	2.34	OCT	6.900
3806	6 X 2	2	1.63	3.72	2.82	OCT	6.900
3806	8 X 3/4	3/4	1.26	2.38	1.50	HEX	9.050
3806	8 X 1	1	1.26	2.56	1.72	HEX	9.050
3806	8 X 1 1/2	1 1/2	1.50	3.96	3.10	OCT	9.050
3806	8 X 2	2	1.50	3.96	3.10	OCT	9.050
3806	10 X 3/4	3/4	2.32	2.92	1.69	HEX	11.100
3806	10 X 1	1	2.32	2.92	1.69	HEX	11.100
3806	10 X 1 1/2	1 1/2	2.30	4.37	3.10	HEX	11.100
3806	10 X 2	2	2.30	4.37	3.10	HEX	11.100
3806	12 X 3/4	3/4	2.32	2.92	1.69	HEX	13.200
3806	12 X 1	1	2.32	2.92	1.69	HEX	13.200
3806	12 X 1 1/2	1 1/2	2.30	4.37	3.10	HEX	13.200
3806	12 X 2	2	2.30	4.37	3.10	HEX	13.200

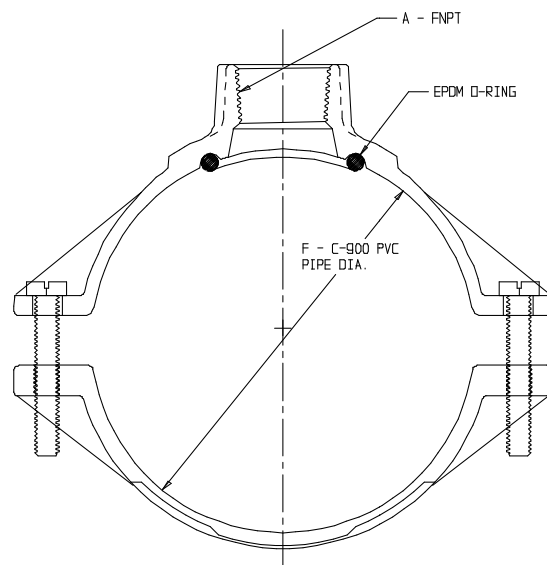
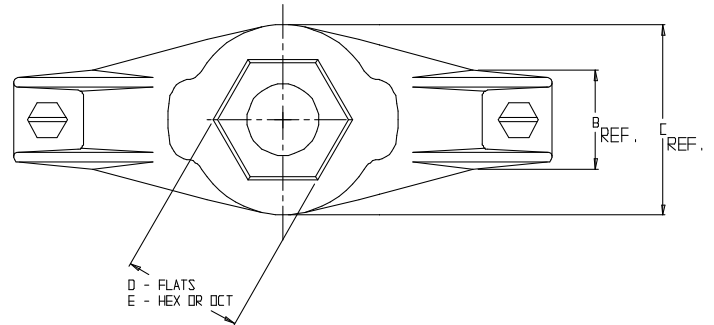

SUBMITTAL INFORMATION

- Manufactured in compliance with ANSI/AWWA C800 (latest revision)
- Brass components conform to ASTM B62 and ASTM B584, UNS C83600 -85-5-5-5 (latest revision)
- Certified to NSF/ANSI 61
- Silicon Bronze bolts
- EPDM o-ring
- Pipe and tap size, and thread type identified on saddle
- Outlet boss with large wrench flats



A.Y. McDonald Mfg. CO.
P.O. Box 508
Dubuque, IA 52004-508

Toll Free: 1-800-292-2737
Fax: 1-800-832-9296
Hours: 7:00 a.m. – 5:00 p.m., CST

sales@aymcdonald.com
www.aymcdonald.com

A.Y. McDonald considers the information on this assembly drawing correct when published. Item and option availability, including specifications, are subject to change without notice.

Submitted by: